

www.lukas-erzett.com



Products. Applications. 2015

Always the right tool





Unique. Multi-talented. LUKAS

ROTTLUFF

A strong brand of
the LUKAS group

**Continuous process
development**

Changes
create new
possibilities

**My individual
tooling solution**

Individual.
Problem solver.
Innovative.

**We are there
for you**

**Assortments for
distributors**

Excellent presentation
at point of sale

Quality is not by chance

High performance
consistency at
all levels

$E = iq + M^2$

Success = innovative quality
+ focus on people

**A strong brand
awareness**



**Challenges drive
us to a first class
performance**

**See. Learn.
Apply.**

Product range

- High Performance
- Industry
- Base

**Optimised
logistic**

**Multi-faceted.
Ability in abundance.
A network.**



Forceful product and technological development

Identify trends early and immediately formulate the correct solution.

Family concern

A stable balance of growth, risk and return

Value proposition

Always the right tool

B2B

There is no such word as „can't“!

Consultation on site

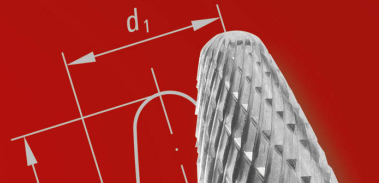

Catalogue

Perfect navigation to the correct tool

Focus on people

Our employees are the most important tool



Powerful tool innovations at a glance



Tungsten Carbide Burrs with TiAlN-coating
For an even longer service life.

Page 56



Rasp burrs and Rotary files
For lightweight materials and excellent surfaces.

Page 57



Burrs with extended shank length
For places difficult to reach.

Page 60



Mounted points in CERAMIC quality
For the hardest materials.

From page 106



Mounted points, HOK type
With spherical shape aluminium oxide for rubber and plastics.

Page 110



Mounted points, conical, RKD 46 O V13
For welding seam machining.

Page 118

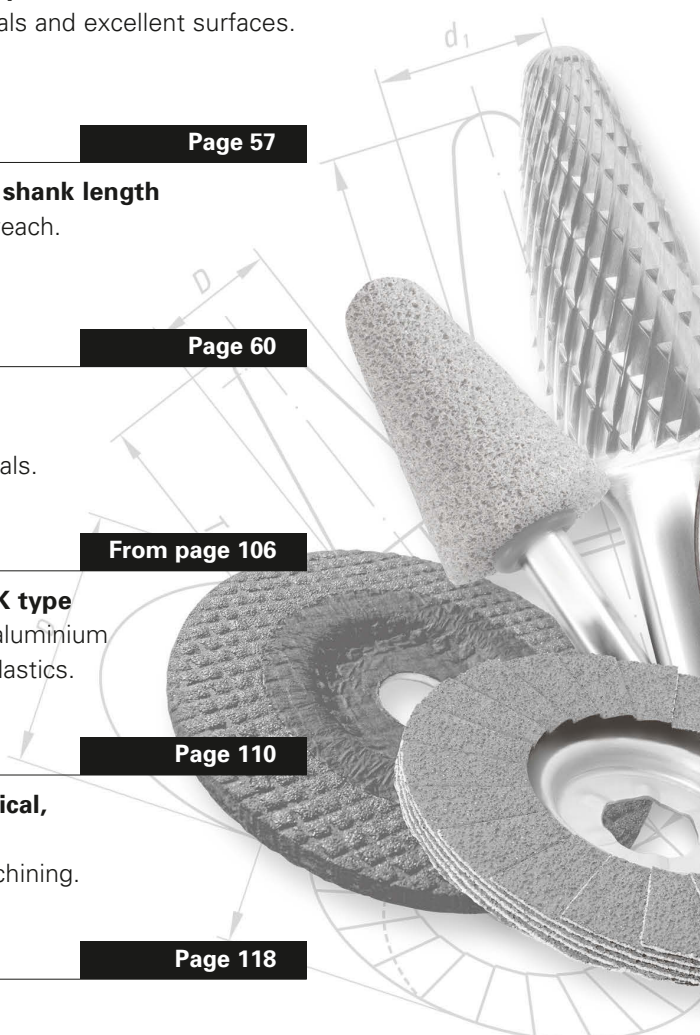



Polishing wheels, group P6

For best surface finishes.

Page 157



Cutting and grinding discs in a new design

For greater perspective.

From page 175



60 new cutting and grinding discs

Perfectly engineered for your application.

From page 184



Abrasive disc for cutting and deburring

For rapid, efficient working.

Page 200



Diamond disc LD3 S13

For top performance in granite, concrete and construction material.

Page 217

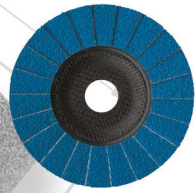

Flap disc V2 Power

Now also available with 230 mm diameter.

Page 238

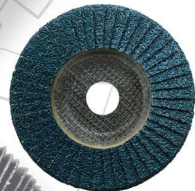

Flap disc V4 Master

For rounding off sharp edges.

Page 244

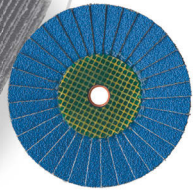

Flap disc SLTflex – the fillet weld professional

Now with M14 or 5/8" thread.

Page 246



...and even more innovations



Flap disc SLTK with plastic backing plate
For every application.

Page 255



LSL- the flap wheel for angle grinders
Now with M14 or 5/8" thread.

Page 288



Mounted flap wheel with zirconia fleece
For a perfect finish.

Page 277

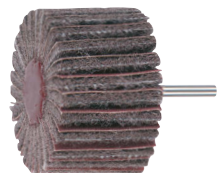

Mounted flap wheel with TF fleece
With reinforced fleece for uniform wear.

Page 281



Conditioning rolls with thread
For speed-controlled angle grinders.

From page 297



Abrasive caps NKS
Improved industrial quality.

From page 321

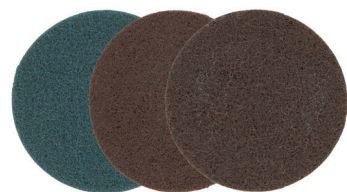

Abrasive fleece discs
For eccentric and angel grinders.

Page 348

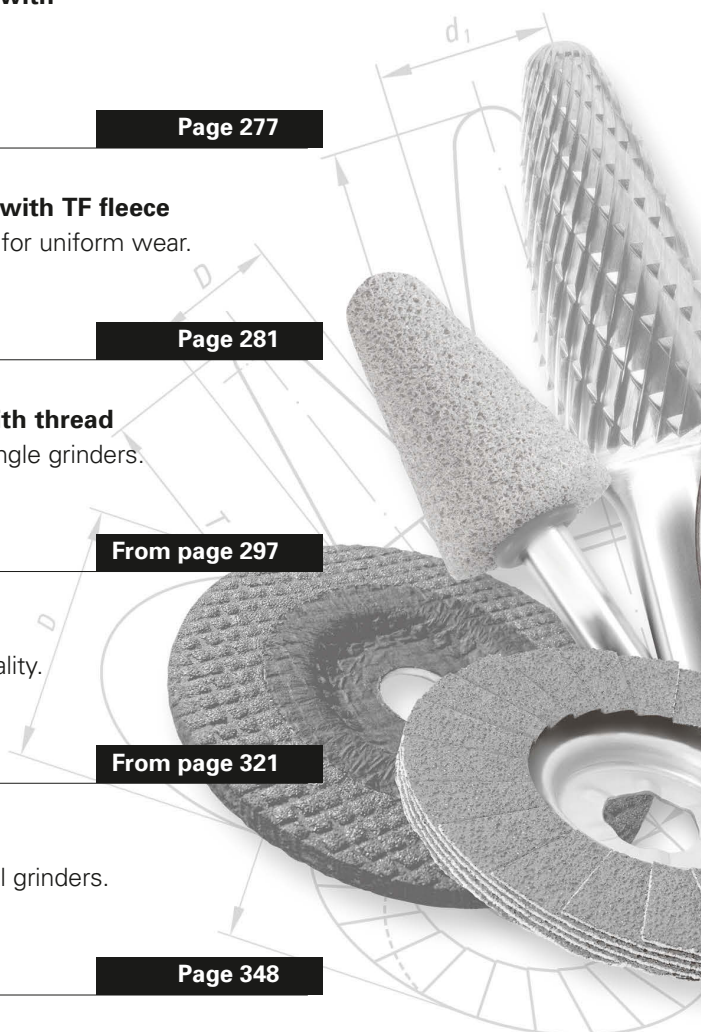



Semi-flexible grinding disc SHF

For paint, adhesive, plastic, etc.

Page 354



Backing pad STF HL with cooling ribs

For optimum cooling and increased performance.

Page 355



Power tools TGD with turbo drive

Maximum speed and performance.

Page 396



Conditioning machine ESM

Creates high-gloss stainless steel surfaces.

Page 398



LUKAS dealer products for point of sale

A wide range of new packaging for dealers.

From page 400



Arbors ASB

For optimum mounting.

From page 410

LUKAS tool recommendation – the free test package

For testing selected tools.

On the internet under www.lukas-erzett.com





My idea.
Professionally put into practice.
My success.

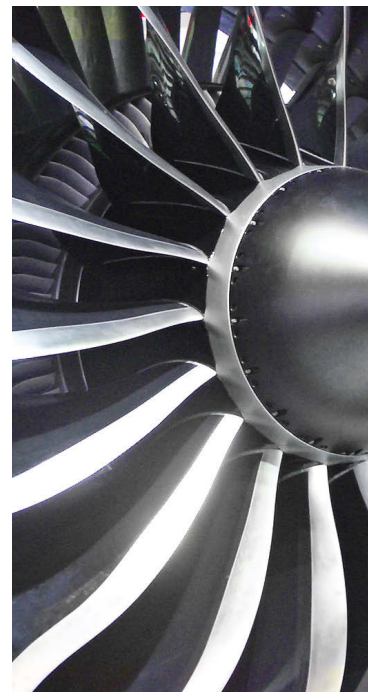
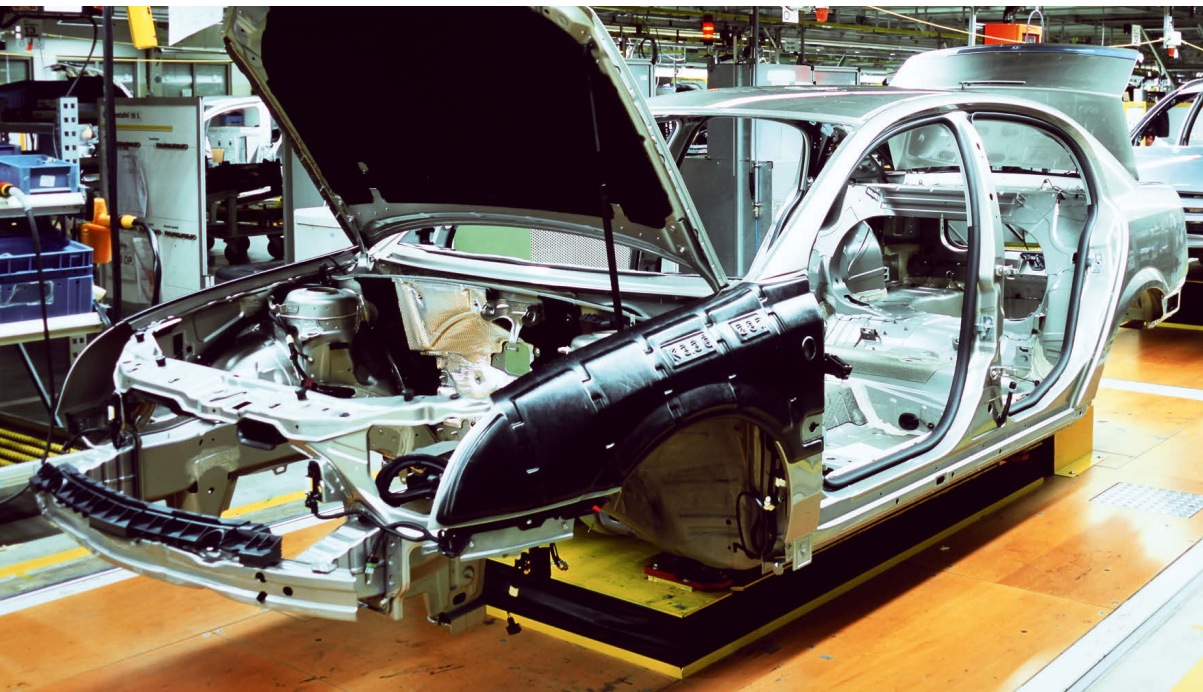
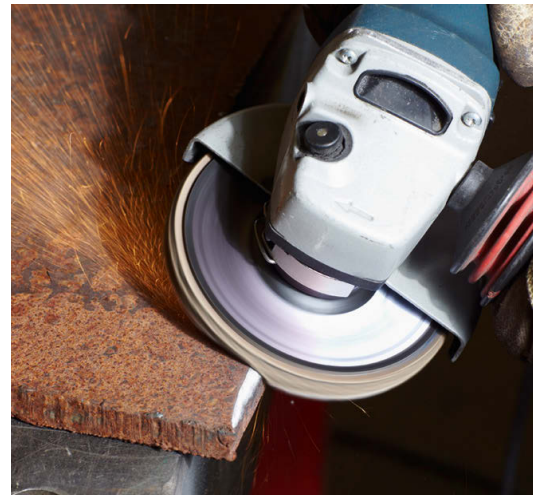

Unique. Versatile. LUKAS.

Our value proposition “Always the right tool at hand” is a promise that we, as an owner-managed international industrial company, have adhered to day by day for your benefit – for more than 75 years!

Excellent quality, high performance and efficiency – these are the advantages you can expect from our brands. Strict quality and safety standards ensure that you can work safely and ergonomically with our tools, despite deadline pressure and a harsh working environment.



We are an internationally recognized specialist in innovative solutions and manufacturer of high performance tooling

We work with you to develop an individual customized solution if you cannot find the right product in our comprehensive catalogue range.

Our application experts and design engineers speak your language and are committed to providing maximum service by gaining a thorough understanding of your processes.

Contact us today! We assist you in selecting your individual tooling requirements.





LUKAS – high performance tools for the world market



LUKAS site 1, Engelskirchen

**Schleifscheibenfabrik Rottluff,
Chemnitz**

As a leading European specialist for the development and manufacture of high quality tools for deburring, grinding and polishing, we have high expectations: the consistent achievement of customer satisfaction.

Partly through our innovative production solutions, we provide you with a competitive edge which will contribute to your success in the marketplace. We advise and support you via our international organisations.



LUKAS-sales-team national



L. Alberts



N. Behnke



F. Bosbach



G. Böttcher



T. Heuschen



E. Jensch



C. Pallesche



M. Pollak



G. Rosner



L. Schultz



U. Thomas

**We are there
for you:**

Fon +49 2263 84-0
Fax +49 2263 84-327
le@lukas-erzett.de

LUKAS-sales-team international



J. Alef



A. Altrock



A. Angres



C. Biesenbach



A. Bittner



P. Bojar



M.-T. Cadelano



Y. El Mejdafi



S. M. Geppert



M. W. Held



C. Hoffmann



S. Holtzem



D. Konopka



K. Kroner



M. Lopez-Lopez



M. Lozano



S. Marinas



A. Matenia



N. Molleker



N. Poulalier-Thiel



M. Reif



M. Riettmann



B. Schorr



E. Twardowski





Special challenges require special tools



With the resources of a privately owned company and production flexibility, we can offer not only individual solutions but also more than 4,500 ex-stock products with their recommended applications.

As a pioneer of such a customer friendly philosophy, we have at our disposal a solid wealth of experience.

Always the right tool.



Quality is no coincidence

Our goal is high performance: Understand the basic conditions and evaluate daily. This concept is strictly used at all levels – at the desk or workbench. In any event, you can rely on the highly esteemed LUKAS – quality.

All processes are centrally controlled by regular audits of the DQS quality management system (DIN EN 9001: 2008 and VDA 6 Part 4) We live and breathe quality!

We put great emphasis on all aspects of safety – especially the LUKAS abrasive products (in the catalogue bearing the oSa-logo) which are manufactured and tested to the appropriate stringent oSa safety regulations. In addition, we strongly advise that notice is taken of the FEPA safety recommendations when using our abrasive products; these can be downloaded from www.lukas-erzett.com.



Please note the FEPA safety recommendations for the safe handling of grinding tools. These can be downloaded from www.lukas-erzett.com



The Symbol of Safety

Organization for the Safety of Abrasives (oSa), website: www.osa-abrasives.org

In addition, we are members to the following professional associations:



Verband Deutscher Schleifmittelwerke e. V. www.vds-bonn.de



Fachverband Werkzeugindustrie e. V. www.werkzeug.org



Tool safety

We therefore manufacture and test our tools in according with the specifications of the following standards:

- EN 12413** Safety requirements for bonded abrasive products
- EN 13743** Safety requirements for coated abrasive products
- EN 13236** Safety requirements for diamond and CBN products
- EN 1083-2** Power driven brushes - Part 2: Safety requirements



For all materials and for any application

Colour coding system

To easily identify products in the catalogue, we have colour coded our product groups – simply turn to your relevant colour.

Milling and Engraving Tools



CBN- and diamond tools for precision machining



Bonded Grinding and Polishing Tools



Power Tools



Cutting and Grinding Discs



Product selection for retailers, assortments and accessories



Flexible Grinding and Polishing Tools



Which product for which material?

The material best suited to our tools is denoted by numerals for the respective application recommendation. The fold-out on the last page identifies which material relates to which number. To search, simply unfold and you will immediately be able to identify which tool is best suited respectively suitable for a particular material classification.



Material Groups

sixteen different material groups distinguish the area of application for the specific tools. The material-group-no. categorizes the application in conjunction with the material to be processed into best suitable and suitable.

Product lines, series and brands

Product lines and series are identified as follows in product tables:

- 1 Brand identification
- 2 Product line identification
- 3 Product series identification

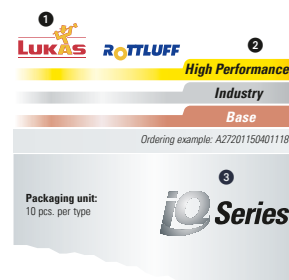

184 Cutting disc										Cutting disc 185										Material classification																																																																																																																																																																																			
A_10000										A_10000										LUKAS																																																																																																																																																																																			
Cutting disc for stainless steel - PROGRESS										Cutting disc for stainless steel - PROMAX										Material classification																																																																																																																																																																																			
High Performance										Industry										Material classification																																																																																																																																																																																			
Description										Description										Material classification																																																																																																																																																																																			
1	2	3	4	5	6	7	8	9	10	11	12	13	14	15	16	17	18	19	20	21	22	23	24	25	26	27	28	29	30	31	32	33	34	35	36	37	38	39	40	41	42	43	44	45	46	47	48	49	50	51	52	53	54	55	56	57	58	59	60	61	62	63	64	65	66	67	68	69	70	71	72	73	74	75	76	77	78	79	80	81	82	83	84	85	86	87	88	89	90	91	92	93	94	95	96	97	98	99	100	101	102	103	104	105	106	107	108	109	110	111	112	113	114	115	116	117	118	119	120	121	122	123	124	125	126	127	128	129	130	131	132	133	134	135	136	137	138	139	140	141	142	143	144	145	146	147	148	149	150	151	152	153	154	155	156	157	158	159	160	161	162	163	164	165	166	167	168	169	170	171	172	173	174	175	176	177	178	179	180	181	182	183	184	185	186	187	188	189	190	191	192	193	194	195	196	197	198	199	200

LUKAS product lines and brands

The quality and categories of our different product lines continue to be identified using colours.

High Performance

Top quality products with an **optimal tool life** to cost ratio



Industry

Proven product range with **excellent performance** to price ratio



Base

Tools with **attractive price** to performance ratio



iQ Series

Within our product identification iQ-Series, we have incorporated our High Performance Range. All aspects have been optimised regarding performance and tool life. You benefit from an exceptional stock removal rate, extremely long tool life, more flexibility in areas of application, etc etc etc.

Technical teaching centre: See. Learn. Apply.



In our modern equipped test and schooling centre, we impart important knowledge regarding our products; and we give you the opportunity in the adjoining test centre to put theory into practise.

We would be pleased to arrange for you:

- **Practical and theoretical schooling**
- **Competent technical product advice**
- **Individual tooling trials**

**Call us: +49 2263 84-0
and make an appointment
with us.**

We would appreciate your visit

Do you want to experience LUKAS live? We would be pleased to give you a personal invitation and welcome you to Engelskirchen. We are glad to be of service and would appreciate the opportunity to demonstrate emphatically how you can benefit from applying our tooling solutions; these can be individually tailored to your specific requirements.



LUKAS-ERZETT Vereinigte Schleif- und Fräswerkzeugfabriken GmbH & Co. KG
Gebrüder-Lukas-Straße 1
51766 Engelskirchen · Germany
Fon +49 2263 84-0 · Fax +49 2263 84-300
le@lukas-erzett.de





Fast. Safe. Cost-effective.

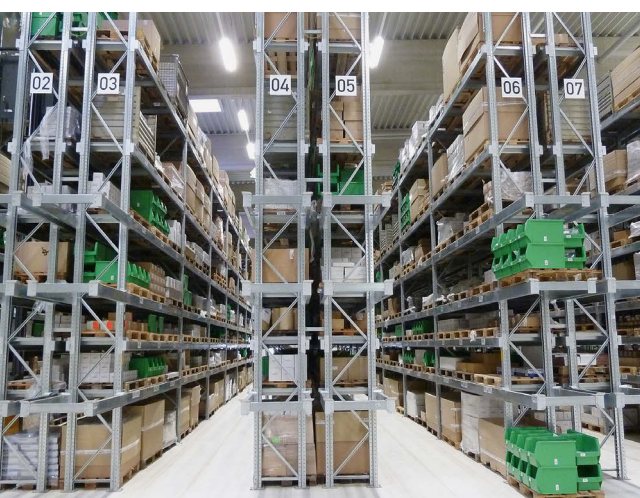

Optimal logistics ensures maximum service.

Since the end of April 2013 tightened safety regulations are valid EU-wide for airfreight shipments. According to the new regulations the airfreight of a company can only be considered as "safe" if it has the status of „officially recognized known sender“.

If this status is missing, the freight has to be considerably checked by a service provider – higher costs and possible delays are the consequences.

We are one of the first companies which has been validated by the Federal Aviation Office as "Known Sender". On April 25th, 2013 – even before the amendment came into effect we were granted the authorization of the Federal Aviation Office.

Due to the status „Known Sender“ we are able to hand over your airfreight – fast, safe and cost-effective – to a certified forwarding company without further examination.

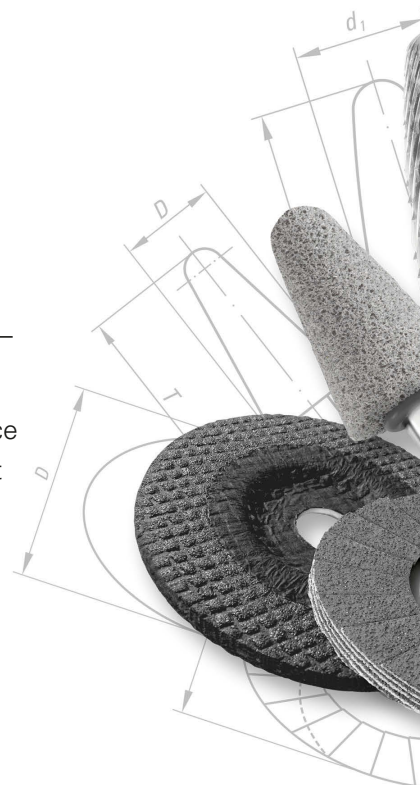

Top services for you

In addition to developing outstanding and innovative tools, we make focused investments in optimizing our services. A good example for this is our new logistics centre at Engelskirchen.

With this centre, we are able to supply goods across Europe within just 48 hours. We believe that this contributes to smooth workflows for your production and ensures that we are more closely involved in your processes.

Our optimized logistics service includes the use of advanced Navision ERP software with tailored eCommerce solutions. Using this software, we can provide electronic catalogues to BME standard or can handle your orders electronically right up to the delivery note.

We offer data handling in all current formats (ASCII, XML, EDIFACT, VDA, BMECat, Opentrans) as well as transmission via http, https, Telebox, e-mail or Odette. In addition, connection with NEXMART, the dealer portal for hardware, tools and fittings, is available.



Our IT-staff is always at your disposal for any advice

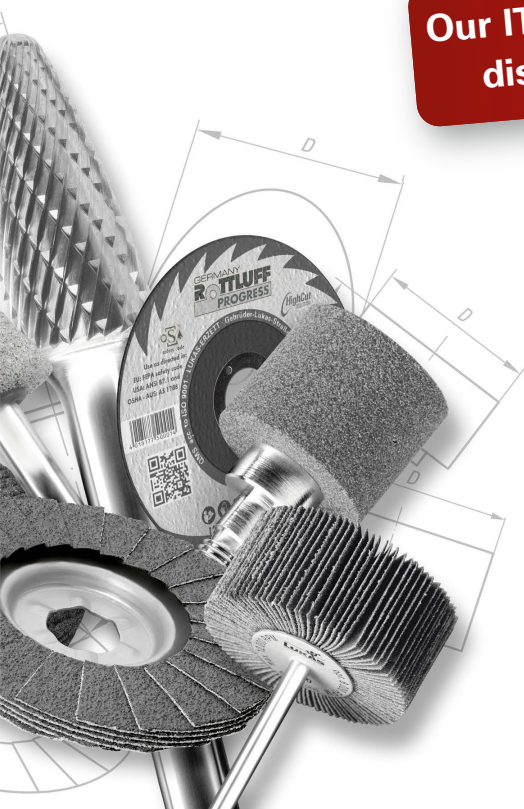



LUKAS Products for Retailers

We have packaged some of our products in special boxes designed specifically for the retail trade. To support you in selling our products with strong and uniform brand positioning, we will also send you practical presentation racks in an eye-catching design.



Excellent Presentation

By lighting the racks from above, the attention of your customers will be drawn straight to the products.



Customer Friendly Assortment

The pegs can be placed in the back wall of the rack in many different ways so you can present the LUKAS product line in many different ways.



Practical Drawer

The drawer in the rack provides you with enough space to maintain an adequate supply.



The LUKAS dealer range comprises:

- iQ series
- Mounted points
- Mounted flap wheels
- Tungsten carbide burrs
- Tool-sets



LUKAS sales promotion at the POS

We have greatly enhanced our dealer portfolio so that you can offer a broader LUKAS range, which includes tools for different applications. In addition to the iQ series, we provide mounted points, mounted flap wheels, tungsten carbide burrs und tool-sets in modern, appealing LUKAS sales packaging.

All packs come with the information necessary for your customers to be able to choose the tool they want without the need to ask. The POS presentation format enables customers to pick up the packs themselves, whilst at the same time serves as a point of contact if they wish to ask for more information about products and the product range.

With the versatile LUKAS dealer range, you can attract additional target groups, who regard outstanding quality and the good image of an established brand as being of great importance.



Milling and Engraving Tools

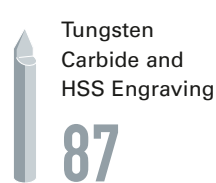
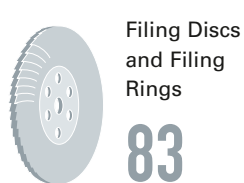
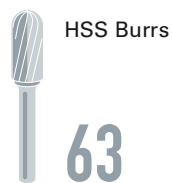
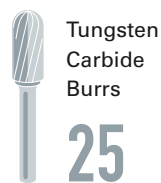

Bonded Grinding and Polishing Tools

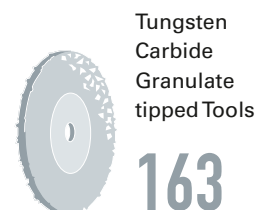
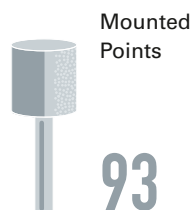

Cutting and Grinding Discs

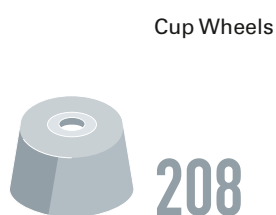
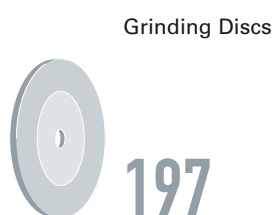
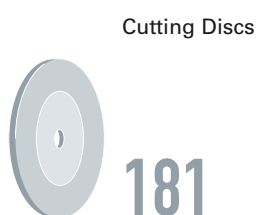

Flexible Grinding and Polishing Tools

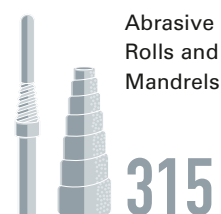
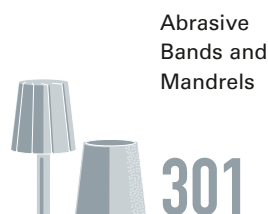
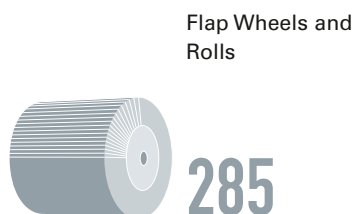
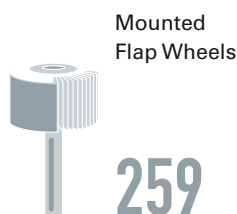

CBN- and diamond tools for precision machining

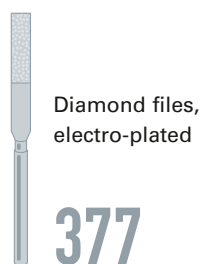
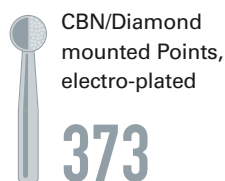

Air Tools



Product selection for retailers, assortments and accessories

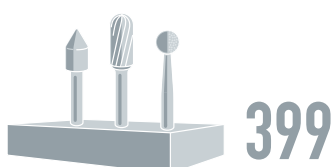

Index

427

Technical
Brushes



167

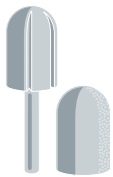

Abrasive Caps
and Mandrels,
Abrasive Sleeves
and Mandrels

319

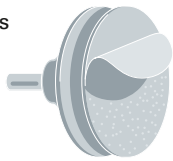

Abrasive Discs
and Mandrels

331



Fibre discs, backing
plates, economy rolls,
abrasive sheets
and fleece rolls

349

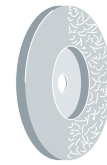

AS-cleaning
fleece

359

Tungsten Carbide Burrs

- 26 Technical Information

- 27 A summary of available shapes

- 28 Recommendations for use and cuts

- 30 Choosing the appropriate Burr

- 31 Coatings

- 32 Tungsten Carbide Burrs



Product line marking

Product lines are labelled in the table header with the appropriate tabs. Further information on page **14** and **15**.



Technical Information

Quality

LUKAS carbide burrs are manufactured using high quality types of carbide and modern CNC automatic grinding machines in order to guarantee precision and repeatability of angle, profile and twist. Carbide burrs manufactured to your drawings or details assist in solving your particular stock removal problem.

Application

The best results are obtained by selecting the recommended cut and speed. Please refer to the cutting speeds in the table on page **28** or according to the table illustrating the various cuts on page **29**.

Power tools

Electric and pneumatic power tools are used; the bearings should be in good condition and the collets running true. Vibration and chatter will cause premature wear and tooth breakage. High pressure will reduce tool life and decreases tool efficiency.

Shanks

For safety reasons the largest possible shank diameter should always be selected from the table. Other shank diameters and lengths are available on request. A selection of burrs with extra long shanks appears on page **60**.

Robot application

LUKAS tungsten carbide burrs are precision tools, and have produced excellent results when used in conjunction with industrial robots. We can also develop the optimal burr for your particular application.

Coated

The reasons for producing cutting tools with hard coatings such as TiN, TiCN, TiALN and LTE are as follows:

- to increase tool life
- to reduce machining forces
- to improve chip removal

The increase in tool life is mainly the result of the considerably higher surface hardness of the coating in comparison to the base material of the tool itself. In addition, due to the high chemical stability, it minimizes the reaction between the cutting edge of the tool and the chip to be removed.

The reduction of machining forces and the improvement in chip removal are achieved through a reduction in the friction between the free cutting zone of the tool and workpiece on the one hand, and the cutting edge of the tool and the chip removed on the other. The reduction in friction depends on the coating improving the surface finish and as previously described by largely avoiding any chemical reaction.

Our technicians would be pleased to help you in the selection of the correct coating. Please note the different possibilities on page **31**.

Special tools

Tungsten carbide burrs manufactured to your design or drawing guarantee the LUKAS high quality standard, and can therefore assist in solving your particular machining problem.

Packaging

We use plastics-packaging; please select the respective packing unit from our product lists.

Recommendations for use

Select the cut to suit the material to be machined. Please kindly follow the principle: **The harder the material, the finer the cut!** The correct selection of speed is the basis of achieving optimum machining results and long tool-life; please refer to the adjoining table. On the following pages you will find some assistance to choose the right speed for your process. Use the highest possible speed within the indicated area.

Too low a speed results in vibration, chipping and premature wear! Reduce the speed of the burrs only when using in large arc angles or when used on low heat conducting materials. Never let the shank and head become discoloured blue. For safety reasons, extended shanks should also be run at low speed.

The power of your machine should be compatible with the machining process. A reduction in RPM due to lack of power – particularly common with pneumactic tools – should be avoided. Collets must run true. Run-out and vibration will result in chipping and premature wear.

For the same reasons, take care that the machine bearings are in perfect condition.

To avoid vibrations and shank breakage, select the shortest shank overhang as possible.

A summary of available shapes

Shape	Type	Shape			Page
		DIN 8033	DIN 7755	LUKAS	
	Cylindrical	ZYA	7755/2	A	32
	Cylindrical round nose	WRC	7755/3	C	35
	Spherical	KUD	7755/4	D	37
	Oval	TRE	7755/5	E	39
	Arch round nose	RBF	7755/6	F	40
	Arch pointed nose	SPG	7755/7	G	41
	Flame	–	7755/8	H	43
	Internal	–	–	I	43
	Counter sink	KSJ	7755/9	J	44
	Conical round nose	KEL	7755/10	L	44
	Conical pointed nose	SKM	7755/11	M	46
	Inverted cone	WKN	7755/12	N	47
	Burrs for the machining of plastic	–	–	P	48
	Engraving Cutters	–	–	–	49
	Burrs for radius trimming (external)	–	–	R	50
	Burrs for radius trimming (internal)	–	–	S	50
	Miniature Burrs	–	–	–	51
	Small Burrs	–	–	–	52
	Tool-Set	–	–	–	54
	Burrs with TiAlN-coating	–	–	–	56
	Rasp burrs	–	–	–	57
	Rotary files	–	–	–	58
	Burrs for machining of non-ferrous metals	–	–	–	59
	Burrs with extended shank length	–	–	–	60
	Some examples of our competitive performance	–	–	–	62
	Power Tools	–	–	–	381

Three steps to your optimum burr:

- 1 Select the **material** and **machining mode** (coarse to fine) from the table and
- 2 read off the recommended **cut** and **cutting speed**.
- 3 Determine the appropriate **speed** for your power tool in the second table.

Recommendations for use of tungsten carbide burrs

1				2		
Material	Lukas material group (see also fold-out tab)	Strength [N/mm ²]	Machining	Cut	Recommended cutting speed vc [m/min]	
Steel, cast steel	1 STEEL AND CAST STEEL	< 800	coarse	Z3, Z7, ZX	500 – 700	
			medium	Z5	300 – 500	
			fine	ZF3	500 – 700	
	2 ALLOYED/HARDENED & TEMPERED STEELS	800 to 1200	coarse	Z7, ZX	400 – 600	
			medium	Z5	300 – 400	
			fine	ZF3	400 – 600	
	3 TOOL STEELS	> 1200	coarse	Z7, Z4	300 – 500	
			medium	Z5	300 – 400	
			fine	ZF3	400 – 600	
Stainless steel	4 RUST/ACID/HEAT-RESISTANT STEEL AND CAST STEEL	up to 800	coarse	Z2, Z6	400 – 500	
			medium	Z3, Z7, Z4, Z5	300 – 500	
			fine	ZF3	400 – 600	
Cast metal	5 CAST IRON	150 to 300	coarse	Z6	400 – 600	
			medium	Z7	300 – 500	
	300 to 450	coarse	Z7	300 – 500		
		medium	Z5	300 – 500		
		fine	ZF3	400 – 700		
Non-ferrous metal 1	6 ALUMINIUM, MAGNESIUM AND COPPER ALLOYS	up to 450	coarse	Z9	600 – 1000	
			medium	Z1	500 – 900	
	BRASS, BRONZE, TITANIUM	up to 450	coarse	Z9, Z1	400 – 800	
			medium	Z2	400 – 600	
		from 450	fine	ZF3	500 – 600	
Non-ferrous metal 2	7 TITANIUM AND NICKEL ALLOYS	up to 900	coarse	Z6	300 – 500	
			medium	Z7	300 – 400	
			fine	ZF3	500 – 700	
		900 to 1500	coarse	Z4	300 – 400	
			medium	Z5	400 – 500	
			fine	ZF3	400 – 600	
	Plastics and wood	8 PLASTIC/WOOD/RUBBER	20 to 400	coarse	Z1, Z9	500 – 1000
				fine	ZP, ZR2	500 – 900
			400 to 1000	coarse	Z1	500 – 800
	fine	Z2, ZR2	400 – 800			

Tip: Page 27 contains a complete overview of the shapes for your chosen milling tool.

Machining



Rotational speeds for milling tools based on the tool diameter and cutting speed

3									
Recommended cutting speed v_c [m/min]									
		300	400	500	600	700	800	900	1000
		Rotational speed [min ⁻¹]							
Tool diameter [mm]	2	48.000	64.000	80.000	95.000	111.000	127.000	143.000	159.000
	3	32.000	42.000	53.000	64.000	74.000	85.000	95.000	106.000
	4	24.000	32.000	40.000	48.000	56.000	64.000	72.000	80.000
	6	16.000	21.000	27.000	32.000	37.000	42.000	48.000	53.000
	8	12.000	16.000	20.000	24.000	28.000	32.000	36.000	40.000
	10	10.000	13.000	16.000	19.000	22.000	25.000	29.000	32.000
	12	8.000	11.000	13.000	16.000	19.000	21.000	24.000	27.000
	16	6.000	8.000	10.000	12.000	14.000	16.000	18.000	20.000
	20	5.000	6.000	8.000	10.000	11.000	13.000	14.000	16.000



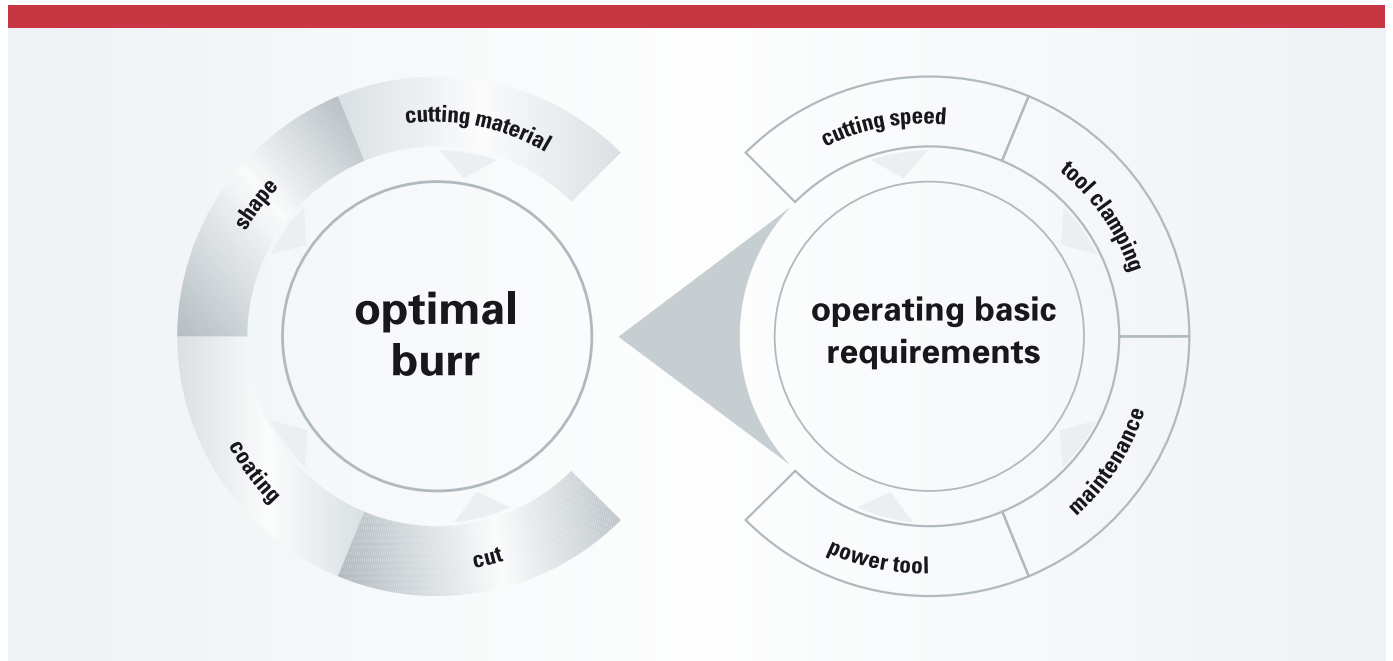

Cuts

	Z 9	Very coarse single cut with faceting for soft materials		Z 4	Fine cross cut for hard materials
	Z 1	Coarse cut for soft materials		Z 6	Robust cross cut
	Z 2	Robust single cut for high stock removal		Z 7	Medium cross cut
	Z 3	Medium single cut		ZI	Fine cross cut especially to machine the inside of the bore (page 43)
	Z 5	Very fine single cut for high-quality surfaces		ZP	Cross cut for machining plastic (page 48)
	ZF	Very fine cross cut (page 58)		ZX	Universal cross cut for practically every application
	ZR	Rasp cut for pattern construction (page 57)			

Choosing the appropriate Burr

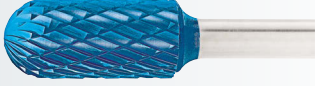

Coatings

Coatings	Specification (LUKAS)	Properties	Friction on steel (dry)
	TiN (Titanium nitride)	general purpose coating for steel and cast iron, high toughness	0,65–0,70 µm
	TiCN (Titanium carbon nitride)	wear resisting coating for fine deburring process; suited to applications with higher thermal and shock loads	0,10–0,20 µm
	TiAlN (Titanium aluminium nitride) (see page 56)	high performance coating with a high degree of hardness and low heat conductivity; therefore suitable for high thermal and mechanical applications	0,30–0,35 µm
	LTE (hard coating carbon-based)	Special coating with lotus-effect for long chip and smearing non-ferrous metals, particularly aluminium alloys. Excellent sliding friction properties reducing loading on cutting edges.	0,10–0,20 µm

The reasons for producing cutting tools with hard coatings are as follows:

- to increase tool life
- to reduce machining forces
- to improve chip removal



Shape A, Cylindrical

Ordering example: A10010210305

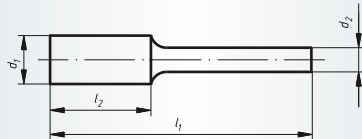

Packing unit:

1 pc. per type

Further dimensions, cuts and shank lengths on request.

Description	Cut	similar DIN 8033	d ₁ mm	l ₂ mm	d ₂ mm	l ₁ mm	Product-Number	recommended for								New burrs	
								1	2	3	4	5	6	7	8		
HFA 0210.03	Z5	ZYA 0210	2	10	3	40	A10010210305	1	2	3	4			7			■
HFA 0313.03	Z3	ZYA 0313	3	13	3	40	A10010313303	1	2	3	4			7			■
HFA 0313.03	Z4	ZYA 0313	3	13	3	40	A10010313304		2	3	4			7	8		■
HFA 0313.03	Z5	ZYA 0313	3	13	3	40	A10010313305	1	2	3	4			7			■
HFA 0313.03	Z7	ZYA 0313	3	13	3	40	A10010313308	1	2	3		5		7			■
HFA 0413.06	Z3	ZYA 0413	4	13	6	50	A10010413603	1	2	3	4			7			■
HFA 0413.06	Z7	ZYA 0413	4	13	6	50	A10010413608	1	2	3		5		7			■
HFA 0607.03	Z5	ZYA 0607	6	7	3	37	A10010607305	1	2	3	4			7			■
HFA 0613.03	Z5	ZYA 0613	6	13	3	43	A10010613305	1	2	3	4			7			■
HFA 0613.03	Z7	ZYA 0613	6	13	3	43	A10010613308	1	2	3		5		7			■
HFA 0616.06	Z2	ZYA 0616	6	16	6	50	A10010616602					5	6		8		■
HFA 0616.06	Z3	ZYA 0616	6	16	6	50	A10010616603	1	2	3	4			7			■
HFA 0616.06	Z4	ZYA 0616	6	16	6	50	A10010616604		2	3	4			7	8		■
HFA 0616.06	Z5	ZYA 0616	6	16	6	50	A10010616605	1	2	3	4			7			■
HFA 0616.06	Z7	ZYA 0616	6	16	6	50	A10010616608	1	2	3		5		7			■
HFA 0616.06	Z9	ZYA 0616	6	16	6	50	A10010616609						6		8		■
HFA 0820.06	Z3	ZYA 0820	8	20	6	60	A10010820603	1	2	3	4			7			■
HFA 0820.06	Z4	ZYA 0820	8	20	6	60	A10010820604		2	3	4			7	8		■
HFA 0820.06	Z5	ZYA 0820	8	20	6	60	A10010820605	1	2	3	4			7			■
HFA 0820.06	Z7	ZYA 0820	8	20	6	60	A10010820608	1	2	3		5		7			■
HFA 1013.06	Z3	ZYA 1013	10	13	6	53	A10011013603	1	2	3	4			7			■
HFA 1013.06	Z7	ZYA 1013	10	13	6	53	A10011013608	1	2	3		5		7			■
HFA 1013.08	Z3	ZYA 1013	10	13	6	53	A10011013803	1	2	3	4			7			■
HFA 1020.06	Z3	ZYA 1020	10	20	6	60	A10011020603	1	2	3	4			7			■
HFA 1020.06	Z4	ZYA 1020	10	20	6	60	A10011020604		2	3	4			7	8		■
HFA 1020.06	Z7	ZYA 1020	10	20	6	60	A10011020608	1	2	3		5		7			■
HFA 1025.06	Z4	ZYA 1025	10	25	6	65	A10011025604		2	3	4			7	8		■
HFA 1025.06	Z7	ZYA 1025	10	25	6	65	A10011025608	1	2	3		5		7			■
HFA 1025.08	Z3	ZYA 1025	10	25	8	65	A10011025803	1	2	3	4			7			■
HFA 1225.06	Z3	ZYA 1225	12	25	6	65	A10011225603	1	2	3	4			7			■
HFA 1225.06	Z4	ZYA 1225	12	25	6	65	A10011225604		2	3	4			7	8		■
HFA 1225.06	Z5	ZYA 1225	12	25	6	65	A10011225605	1	2	3	4			7			■
HFA 1225.06	Z7	ZYA 1225	12	25	6	65	A10011225608	1	2	3	4			7			■
HFA 1225.06	Z9	ZYA 1225	12	25	6	65	A10011225609						6		8		■
HFA 1225.08	Z4	ZYA 1225	12	25	8	65	A10011225804		2	3	4			7	8		■
HFA 1225.08	Z9	ZYA 1225	12	25	8	65	A10011225809						6		8		■
HFA 1625.06	Z3	ZYA 1625	16	25	6	65	A10011625603	1	2	3	4			7			■
HFA 1625.06	Z7	ZYA 1625	16	25	6	65	A10011625608	1	2	3		5		7			■
HFA 1625.06	Z9	ZYA 1625	16	25	6	65	A10011625609						6		8		■
HFA 1625.08	Z9	ZYA 1625	16	25	8	65	A10011625809						6		8		■



Base

Shape A, Cylindrical BASE-X

Ordering example: A10010313322

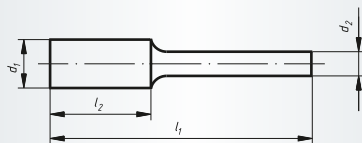

Packing unit:
10 pcs. per type,
from Ø 12 mm: 5 pcs. per type

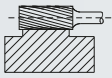
Description	Cut	similar DIN 8033	d ₁ mm	l ₂ mm	d ₂ mm	l ₁ mm	Product-Number	recommended for	New burrs
HFA 0313.03 BASE-X	ZX	ZYA 0313	3	13	3	40	A10010313322	 1 2 3 4 5 7	■
HFA 0616.06 BASE-X	ZX	ZYA 0616	6	16	6	50	A10010616622	1 2 3 4 5 7	■
HFA 0820.06 BASE-X	ZX	ZYA 0820	8	20	6	60	A10010820622	1 2 3 4 5 7	■
HFA 1020.06 BASE-X	ZX	ZYA 1020	10	20	6	60	A10011020622	1 2 3 4 5 7	■
HFA 1225.06 BASE-X	ZX	ZYA 1225	12	25	6	65	A10011225622	1 2 3 4 5 7	■



Always the right tool



Mounted points and polishing points:
11,000 specially produced items according to customers' requests reflect the big variety of these products.

Martin Reif
Sales Department

www.lukas-erzett.com



Shape A, Cylindrical, with end-cut

Ordering example: A100102103050001

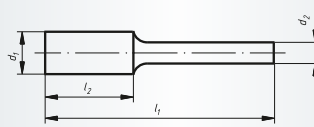

Packing unit:

1 pc. per type

Further dimensions, cuts and shank lengths on request.

Description	Cut	similar DIN 8033	d ₁ mm	l ₂ mm	d ₂ mm	l ₁ mm	Product-Number	recommended for										New burrs				
								1	2	3	4	5	6	7	8	9	10		11	12		
HFAS 0210.03	Z5	ZYA-S 0210	2	10	3	40	A100102103050001	1	2	3	4					7						■
HFAS 0313.03	Z3	ZYA-S 0313	3	13	3	40	A100103133030001	1	2	3	4					7						■
HFAS 0313.03	Z4	ZYA-S 0313	3	13	3	40	A100103133040001		2	3	4					7	8					■
HFAS 0313.03	Z5	ZYA-S 0313	3	13	3	40	A100103133050001	1	2	3	4					7						■
HFAS 0313.03	Z7	ZYA-S 0313	3	13	3	40	A100103133080001	1	2	3			5		7							■
HFAS 0413.06	Z3	ZYA-S 0413	4	13	6	50	A100104136030001	1	2	3	4					7						■
HFAS 0413.06	Z7	ZYA-S 0413	4	13	6	50	A100104136080001	1	2	3			5		7							■
HFAS 0607.03	Z5	ZYA-S 0607	6	7	3	37	A100106073050001	1	2	3	4					7						■
HFAS 0613.03	Z5	ZYA-S 0613	6	13	3	43	A100106133050001	1	2	3	4					7						■
HFAS 0613.03	Z7	ZYA-S 0613	6	13	3	43	A100106133080001	1	2	3			5		7							■
HFAS 0616.06	Z3	ZYA-S 0616	6	16	6	50	A100106166030001	1	2	3	4					7						■
HFAS 0616.06	Z4	ZYA-S 0616	6	16	6	50	A100106166040001		2	3	4					7	8					■
HFAS 0616.06	Z5	ZYA-S 0616	6	16	6	50	A100106166050001	1	2	3	4					7						■
HFAS 0616.06	Z7	ZYA-S 0616	6	16	6	50	A100106166080001	1	2	3			5		7							■
HFAS 0820.06	Z3	ZYA-S 0820	8	20	6	60	A100108206030001	1	2	3	4					7						■
HFAS 0820.06	Z4	ZYA-S 0820	8	20	6	60	A100108206040001		2	3	4					7	8					■
HFAS 0820.06	Z5	ZYA-S 0820	8	20	6	60	A100108206050001	1	2	3	4					7						■
HFAS 0820.06	Z7	ZYA-S 0820	8	20	6	60	A100108206080001	1	2	3			5		7							■
HFAS 1013.06	Z3	ZYA-S 1013	10	13	6	53	A100110136030001	1	2	3	4					7						■
HFAS 1013.06	Z7	ZYA-S 1013	10	13	6	53	A100110136080001	1	2	3			5		7							■
HFAS 1020.06	Z3	ZYA-S 1020	10	20	6	60	A100110206030001	1	2	3	4					7						■
HFAS 1020.06	Z4	ZYA-S 1020	10	20	6	60	A100110206040001		2	3	4					7	8					■
HFAS 1020.06	Z7	ZYA-S 1020	10	20	6	60	A100110206080001	1	2	3			5		7							■
HFAS 1025.06	Z4	ZYA-S 1025	10	25	6	65	A100110256040001		2	3	4					7	8					■
HFAS 1025.06	Z7	ZYA-S 1025	10	25	6	65	A100110256080001	1	2	3			5		7							■
HFAS 1225.06	Z3	ZYA-S 1225	12	25	6	65	A100112256030001	1	2	3	4					7						■
HFAS 1225.06	Z4	ZYA-S 1225	12	25	6	65	A100112256040001		2	3	4					7	8					■
HFAS 1225.06	Z5	ZYA-S 1225	12	25	6	65	A100112256050001	1	2	3	4					7						■
HFAS 1225.06	Z7	ZYA-S 1225	12	25	6	65	A100112256080001	1	2	3			5		7							■
HFAS 1225.08	Z4	ZYA-S 1225	12	25	8	65	A100112258040001		2	3	4					7	8					■
HFAS 1225.08	Z7	ZYA-S 1225	12	25	8	65	A100112258080001	1	2	3			5		7							■
HFAS 1625.06	Z3	ZYA-S 1625	16	25	6	65	A100116256030001	1	2	3	4					7						■
HFAS 1625.06	Z7	ZYA-S 1625	16	25	6	65	A100116256080001	1	2	3			5		7							■



Industry

Shape C, Cylindrical Round nose

Ordering example: A10020210305

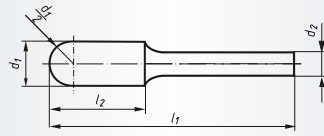

Packing unit:

1 pc. per type

Further dimensions, cuts and shank lengths on request.

Description	Cut	similar DIN 8033	d ₁ mm	l ₂ mm	d ₂ mm	l ₁ mm	Product-Number	recommended for								New burrs	
								1	2	3	4	5	6	7	8		
HFC 0210.03	Z5	WRC 0210	2	10	3	40	A10020210305	1	2	3	4			7			■
HFC 0210.03	Z7	WRC 0210	2	10	3	40	A10020210308	1	2	3		5		7			■
HFC 0313.03	Z2	WRC 0313	3	13	3	40	A10020313302	1				5	6		8		■
HFC 0313.03	Z3	WRC 0313	3	13	3	40	A10020313303	1	2	3	4			7			■
HFC 0313.03	Z4	WRC 0313	3	13	3	40	A10020313304		2	3	4			7	8		■
HFC 0313.03	Z5	WRC 0313	3	13	3	40	A10020313305	1	2	3	4			7			■
HFC 0313.03	Z7	WRC 0313	3	13	3	40	A10020313308	1	2	3		5		7			■
HFC 0413.06	Z3	WRC 0413	4	13	6	50	A10020413603	1	2	3	4			7			■
HFC 0413.06	Z4	WRC 0413	4	13	6	50	A10020413604		2	3	4			7	8		■
HFC 0413.06	Z7	WRC 0413	4	13	6	50	A10020413608	1	2	3		5		7			■
HFC 0613.03	Z5	WRC 0613	6	13	3	43	A10020613305	1	2	3	4			7			■
HFC 0613.03	Z7	WRC 0613	6	13	3	43	A10020613308	1	2	3		5		7			■
HFC 0616.06	Z1	WRC 0616	6	16	6	50	A10020616601						6		8		■
HFC 0616.06	Z2	WRC 0616	6	16	6	50	A10020616602	1				5	6		8		■
HFC 0616.06	Z3	WRC 0616	6	16	6	50	A10020616603	1	2	3	4			7			■
HFC 0616.06	Z4	WRC 0616	6	16	6	50	A10020616604		2	3	4			7	8		■
HFC 0616.06	Z5	WRC 0616	6	16	6	50	A10020616605	1	2	3	4			7			■
HFC 0616.06	Z7	WRC 0616	6	16	6	50	A10020616608	1	2	3		5		7			■
HFC 0616.06	Z9	WRC 0616	6	16	6	50	A10020616609						6		8		■
HFC 0820.06	Z3	WRC 0820	8	20	6	60	A10020820603	1	2	3	4			7			■
HFC 0820.06	Z4	WRC 0820	8	20	6	60	A10020820604		2	3	4			7	8		■
HFC 0820.06	Z5	WRC 0820	8	20	6	60	A10020820605	1	2	3	4			7			■
HFC 0820.06	Z6	WRC 0820	8	20	6	60	A10020820606		2	3	4			7	8		■
HFC 0820.06	Z7	WRC 0820	8	20	6	60	A10020820608	1	2	3		5		7			■
HFC 0820.06	Z9	WRC 0820	8	20	6	60	A10020820609						6		8		■
HFC 1020.06	Z3	WRC 1020	10	20	6	60	A10021020603	1	2	3	4			7			■
HFC 1020.06	Z4	WRC 1020	10	20	6	60	A10021020604		2	3	4			7	8		■
HFC 1020.06	Z5	WRC 1020	10	20	6	60	A10021020605	1	2	3	4			7			■
HFC 1020.06	Z6	WRC 1020	10	20	6	60	A10021020606		2	3	4			7	8		■
HFC 1020.06	Z7	WRC 1020	10	20	6	60	A10021020608	1	2	3		5		7			■
HFC 1020.08	Z4	WRC 1020	10	20	8	60	A10021020804		2	3	4			7	8		■
HFC 1020.08	Z7	WRC 1020	10	20	8	60	A10021020808	1	2	3		5		7			■
HFC 1025.06	Z7	WRC 1025	10	25	6	65	A10021025608	1	2	3		5		7			■
HFC 1225.06	Z1	WRC 1225	12	25	6	65	A10021225601						6		8		■
HFC 1225.06	Z2	WRC 1225	12	25	6	65	A10021225602	1				5	6		8		■
HFC 1225.06	Z3	WRC 1225	12	25	6	65	A10021225603	1	2	3	4			7			■
HFC 1225.06	Z4	WRC 1225	12	25	6	65	A10021225604		2	3	4			7	8		■
HFC 1225.06	Z5	WRC 1225	12	25	6	65	A10021225605	1	2	3	4			7			■
HFC 1225.06	Z6	WRC 1225	12	25	6	65	A10021225606		2	3	4			7	8		■
HFC 1225.06	Z7	WRC 1225	12	25	6	65	A10021225608	1	2	3		5		7			■



Shape C, Cylindrical Round nose

Ordering example: A10021225609

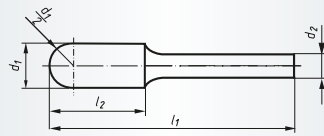

Packing unit:

1 pc. per type

Further dimensions, cuts and shank lengths on request.

Description	Cut	similar DIN 8033	d ₁ mm	l ₂ mm	d ₂ mm	l ₁ mm	Product-Number	recommended for								New burrs	
								1	2	3	4	5	6	7	8		
HFC 1225.06	Z9	WRC 1225	12	25	6	65	A10021225609						6		8		■
HFC 1225.08	Z3	WRC 1225	12	25	8	65	A10021225803	1	2	3	4				7		■
HFC 1225.08	Z4	WRC 1225	12	25	8	65	A10021225804		2	3	4				7	8	■
HFC 1225.08	Z7	WRC 1225	12	25	8	65	A10021225808	1	2	3		5		7		■	
HFC 1225.08	Z9	WRC 1225	12	25	8	65	A10021225809						6		8	■	
HFC 1625.06	Z3	WRC 1625	16	25	6	65	A10021625603	1	2	3	4				7		■
HFC 1625.06	Z7	WRC 1625	16	25	6	65	A10021625608	1	2	3		5		7		■	
HFC 1625.06	Z9	WRC 1625	16	25	6	65	A10021625609						6		8	■	
HFC 1625.08	Z3	WRC 1625	16	25	8	65	A10021625803	1	2	3	4				7		■
HFC 1625.08	Z9	WRC 1625	16	25	8	65	A10021625809						6		8	■	



Shape C, Cylindrical Round nose BASE-X

Ordering example: A10020313322

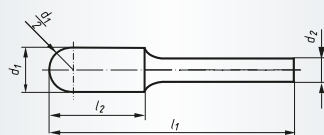

Packing unit:

10 pcs. per type,

from Ø 12 mm: 5 pcs. per type

Description	Cut	similar DIN 8033	d ₁ mm	l ₂ mm	d ₂ mm	l ₁ mm	Product-Number	recommended for								New burrs	
								1	2	3	4	5	6	7	8		
HFC 0313.03 BASE-X	ZX	WRC 0313	3	13	3	40	A10020313322	1	2	3	4	5			7		■
HFC 0613.03 BASE-X	ZX	WRC 0613	6	13	3	43	A10020613322	1	2	3	4	5			7		■
HFC 0616.06 BASE-X	ZX	WRC 0616	6	16	6	50	A10020616622	1	2	3	4	5			7		■
HFC 0820.06 BASE-X	ZX	WRC 0820	8	20	6	60	A10020820622	1	2	3	4	5			7		■
HFC 1020.06 BASE-X	ZX	WRC 1020	10	20	6	60	A10021020622	1	2	3	4	5			7		■
HFC 1225.06 BASE-X	ZX	WRC 1225	12	25	6	65	A10021225622	1	2	3	4	5			7		■



Industry

Shape D, Spherical

Ordering example: A10030303302

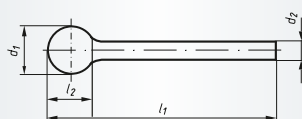

Packing unit:

1 pc. per type

Further dimensions, cuts and shank lengths on request.

Description	Cut	similar DIN 8033	d ₁ mm	l ₂ mm	d ₂ mm	l ₁ mm	Product-Number	recommended for								New burrs	
								1	2	3	4	5	6	7	8		
HFD 0302.03	Z2	KUD 0302	3	2	3	40	A10030303302	1				5	6		8	■	
HFD 0302.03	Z3	KUD 0302	3	2	3	40	A10030303303	1	2	3	4				7	■	
HFD 0302.03	Z4	KUD 0302	3	2	3	40	A10030303304		2	3	4				7	8	■
HFD 0302.03	Z5	KUD 0302	3	2	3	40	A10030303305	1	2	3	4				7	■	
HFD 0302.03	Z7	KUD 0302	3	2	3	40	A10030303308	1	2	3		5			7	■	
HFD 0403.03	Z5	KUD 0403	4	3	3	34	A100304043050001	1	2	3	4				7	■	
HFD 0403.03	Z7	KUD 0403	4	3	3	34	A100304043080001	1	2	3		5			7	■	
HFD 0403.06	Z3	KUD 0403	4	3	6	50	A10030404603	1	2	3	4				7	■	
HFD 0403.06	Z4	KUD 0403	4	3	6	50	A10030404604		2	3	4				7	8	■
HFD 0403.06	Z7	KUD 0403	4	3	6	50	A10030404608	1	2	3		5			7	■	
HFD 0605.03	Z5	KUD 0605	6	5	3	35	A10030606305	1	2	3	4				7	■	
HFD 0605.03	Z7	KUD 0605	6	5	3	35	A10030606308	1	2	3		5			7	■	
HFD 0605.06	Z3	KUD 0605	6	5	6	50	A10030606603	1	2	3	4				7	■	
HFD 0605.06	Z4	KUD 0605	6	5	6	50	A10030606604		2	3	4				7	8	■
HFD 0605.06	Z5	KUD 0605	6	5	6	50	A10030606605	1	2	3	4				7	■	
HFD 0605.06	Z7	KUD 0605	6	5	6	50	A10030606608	1	2	3		5			7	■	
HFD 0807.06	Z3	KUD 0807	8	7	6	47	A10030808603	1	2	3	4				7	■	
HFD 0807.06	Z4	KUD 0807	8	7	6	47	A10030808604		2	3	4				7	8	■
HFD 0807.06	Z5	KUD 0807	8	7	6	47	A10030808605	1	2	3	4				7	■	
HFD 0807.06	Z7	KUD 0807	8	7	6	47	A10030808608	1	2	3		5			7	■	
HFD 1009.06	Z3	KUD 1009	10	9	6	49	A10031010603	1	2	3	4				7	■	
HFD 1009.06	Z4	KUD 1009	10	9	6	49	A10031010604		2	3	4				7	8	■
HFD 1009.06	Z5	KUD 1009	10	9	6	49	A10031010605	1	2	3	4				7	■	
HFD 1009.06	Z7	KUD 1009	10	9	6	49	A10031010608	1	2	3		5			7	■	
HFD 1210.06	Z3	KUD 1210	12	10	6	51	A10031212603	1	2	3	4				7	■	
HFD 1210.06	Z4	KUD 1210	12	10	6	51	A10031212604		2	3	4				7	8	■
HFD 1210.06	Z5	KUD 1210	12	10	6	51	A10031212605	1	2	3	4				7	■	
HFD 1210.06	Z7	KUD 1210	12	10	6	51	A10031212608	1	2	3		5			7	■	
HFD 1210.06	Z9	KUD 1210	12	10	6	50	A10031212609						6		8	■	
HFD 1210.08	Z4	KUD 1210	12	10	8	51	A10031212804		2	3	4				7	8	■
HFD 1210.08	Z7	KUD 1210	12	10	8	51	A10031210808	1	2	3		5			7	■	
HFD 1210.08	Z9	KUD 1210	12	10	8	50	A10031212809						6		8	■	
HFD 1614.06	Z3	KUD 1614	16	14	6	54	A10031616603	1	2	3	4				7	■	
HFD 1614.06	Z4	KUD 1614	16	14	6	54	A10031616604		2	3	4				7	8	■
HFD 1614.06	Z7	KUD 1614	16	14	6	54	A10031616608	1	2	3		5			7	■	
HFD 1614.06	Z9	KUD 1614	16	14	6	54	A10031616609						6		8	■	
HFD 1614.08	Z3	KUD 1614	16	14	8	54	A10031616803	1	2	3	4				7	■	
HFD 1614.08	Z9	KUD 1614	16	14	8	54	A10031616809						6		8	■	



Shape D, Spherical

Ordering example: A10032020603

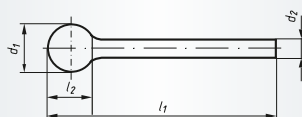

Packing unit:

1 pc. per type

Further dimensions, cuts and shank lengths on request.

Description	Cut	similar DIN 8033	d ₁ mm	l ₂ mm	d ₂ mm	l ₁ mm	Product-Number	recommended for	New burrs
HFD 2018.06	Z3	KUD 2018	20	18	6	58	A10032020603	 1 2 3 4 7	■
HFD 2018.06	Z7	KUD 2018	20	18	6	58	A10032020608	1 2 3 5 7	■
HFD 2018.08	Z3	KUD 2018	20	18	8	58	A10032020803	1 2 3 4 7	■



Shape D, Spherical BASE-X

Ordering example: A10030403322

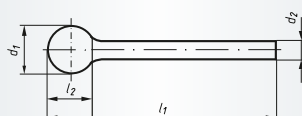

Packing unit:

10 pcs. per type,

from Ø 12 mm: 5 pcs. per type

Further dimensions, cuts and shank lengths on request.

Description	Cut	similar DIN 8033	d ₁ mm	l ₂ mm	d ₂ mm	l ₁ mm	Product-Number	recommended for	New burrs
HFD 0403.03 BASE-X	ZX	KUD 0403	4	3	3	34	A10030403322	 1 2 3 4 5 7	■
HFD 0605.03 BASE-X	ZX	KUD 0605	6	5	3	35	A10030605322	1 2 3 4 5 7	■
HFD 0807.06 BASE-X	ZX	KUD 0807	8	7	6	47	A10030807622	1 2 3 4 5 7	■
HFD 1009.06 BASE-X	ZX	KUD 1009	10	9	6	49	A10031009622	1 2 3 4 5 7	■
HFD 1210.06 BASE-X	ZX	KUD 1210	12	10	6	51	A10031210622	1 2 3 4 5 7	■



Industry

Shape E, Oval

Ordering example: A10060307303

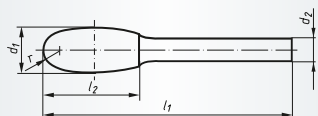

Packing unit:

1 pc. per type

Further dimensions, cuts and shank lengths on request.

Description	Cut	similar DIN 8033	d ₁ mm	l ₂ mm	d ₂ mm	l ₁ mm	r≈ mm	Product-Number	recommended for								New burrs	
									1	2	3	4	5	6	7	8		
HFE 0307.03	Z3	TRE 0307	3	7	3	40	1,2	A10060307303	1	2	3	4			7			■
HFE 0307.03	Z5	TRE 0307	3	7	3	40	1,2	A10060307305	1	2	3	4			7			■
HFE 0307.03	Z7	TRE 0307	3	7	3	40	1,2	A10060307308	1	2	3		5		7			■
HFE 0610.03	Z5	TRE 0610	6	10	3	40	2,8	A10060610305	1	2	3	4			7			■
HFE 0610.03	Z7	TRE 0610	6	10	3	40	2,8	A10060610308	1	2	3		5		7			■
HFE 0610.06	Z3	TRE 0610	6	10	6	50	2,8	A10060610603	1	2	3	4			7			■
HFE 0610.06	Z4	TRE 0610	6	10	6	50	2,8	A10060610604		2	3	4			7	8		■
HFE 0610.06	Z7	TRE 0610	6	10	6	50	2,8	A10060610608	1	2	3		5		7			■
HFE 0813.06	Z3	TRE 0813	8	13	6	53	3,7	A10060813603	1	2	3	4			7			■
HFE 0813.06	Z4	TRE 0813	8	13	6	53	3,7	A10060813604		2	3	4			7	8		■
HFE 0813.06	Z7	TRE 0813	8	13	6	53	3,7	A10060813608	1	2	3		5		7			■
HFE 1220.06	Z3	TRE 1220	12	20	6	60	5,0	A10061220603	1	2	3	4			7			■
HFE 1220.06	Z4	TRE 1220	12	20	6	60	5,0	A10061220604		2	3	4			7	8		■
HFE 1220.06	Z5	TRE 1220	12	20	6	60	5,0	A10061220605	1	2	3	4			7			■
HFE 1220.06	Z7	TRE 1220	12	20	6	60	5,0	A10061220608	1	2	3		5		7			■
HFE 1225.08	Z3	TRE 1225	12	25	8	65	5,0	A10061225803	1	2	3	4			7			■
HFE 1225.08	Z9	TRE 1225	12	25	8	65	5,0	A10061225809						6		8		■
HFE 1625.06	Z7	TRE 1625	16	25	6	65	7,1	A10061625608	1	2	3		5		7			■
HFE 1625.08	Z3	TRE 1625	16	25	8	65	7,1	A10061625803	1	2	3	4			7			■
HFE 1625.08	Z9	TRE 1625	16	25	8	65	7,1	A10061625809						6		8		■
HFE 2035.08	Z3	TRE 2035	20	35	8	75	8,0	A10062035803	1	2	3	4			7			■



Shape F, Arch round nose

Ordering example: A10100307303

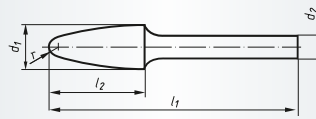

Packing unit:

1 pc. per type

Further dimensions, cuts and shank lengths on request.

Description	Cut	similar DIN 8033	d ₁ mm	l ₂ mm	d ₂ mm	l ₁ mm	r≈ mm	Product-Number	recommended for								New burrs	
									1	2	3	4	5	6	7	8		
HFF 0307.03	Z3	RBF 0307	3	7	3	40	0,75	A10100307303	1	2	3	4			7			■
HFF 0307.03	Z4	RBF 0307	3	7	3	40	0,75	A10100307304		2	3	4			7	8		■
HFF 0307.03	Z5	RBF 0307	3	7	3	40	0,75	A10100307305	1	2	3	4			7			■
HFF 0313.03	Z5	RBF 0313	3	13	3	40	0,75	A10100313305	1	2	3	4			7			■
HFF 0313.03	Z7	RBF 0313	3	13	3	40	0,75	A10100313308	1	2	3		5		7			■
HFF 0613.03	Z5	RBF 0613	6	13	3	43	1,4	A10100613305	1	2	3	4			7			■
HFF 0613.03	Z7	RBF 0613	6	13	3	43	1,4	A10100613308	1	2	3		5		7			■
HFF 0618.06	Z3	RBF 0618	6	18	6	50	1,5	A10100618603	1	2	3	4			7			■
HFF 0618.06	Z4	RBF 0618	6	18	6	50	1,5	A10100618604		2	3	4			7	8		■
HFF 0618.06	Z5	RBF 0618	6	18	6	50	1,5	A10100618605	1	2	3	4			7			■
HFF 0618.06	Z7	RBF 0618	6	18	6	50	1,5	A10100618608	1	2	3		5		7			■
HFF 0820.06	Z3	---	8	20	6	60	1,8	A10100820603	1	2	3	4			7			■
HFF 0820.06	Z7	---	8	20	6	60	1,8	A10100820608	1	2	3		5		7			■
HFF 1020.06	Z3	RBF 1020	10	20	6	60	2,5	A10101020603	1	2	3	4			7			■
HFF 1020.06	Z4	RBF 1020	10	20	6	60	2,5	A10101020604		2	3	4			7	8		■
HFF 1020.06	Z6	RBF 1020	10	20	6	60	2,5	A10101020606		2	3	4			7	8		■
HFF 1020.06	Z7	RBF 1020	10	20	6	60	2,5	A10101020608	1	2	3		5		7			■
HFF 1225.06	Z1	RBF 1225	12	25	6	65	2,5	A10101225601							6		8	■
HFF 1225.06	Z3	RBF 1225	12	25	6	65	2,5	A10101225603	1	2	3	4			7			■
HFF 1225.06	Z4	RBF 1225	12	25	6	65	2,5	A10101225604		2	3	4			7	8		■
HFF 1225.06	Z7	RBF 1225	12	25	6	65	2,5	A10101225608	1	2	3		5		7			■
HFF 1225.06	Z9	RBF 1225	12	25	6	65	2,5	A10101225609						6		8		■
HFF 1225.08	Z3	RBF 1225	12	25	8	65	2,5	A10101225803	1	2	3	4			7			■
HFF 1225.08	Z7	RBF 1225	12	25	8	65	2,5	A10101225808	1	2	3		5		7			■
HFF 1225.08	Z9	RBF 1225	12	25	8	65	2,5	A10101225809						6		8		■
HFF 1230.06	Z3	RBF 1230	12	30	6	70	2,7	A10101230603	1	2	3	4			7			■
HFF 1230.06	Z7	RBF 1230	12	30	6	70	2,7	A10101230608	1	2	3		5		7			■
HFF 1230.08	Z3	RBF 1230	12	30	8	70	2,7	A10101230803	1	2	3	4			7			■
HFF 1630.06	Z7	RBF 1630	16	30	6	70	3,6	A10101630608	1	2	3		5		7			■
HFF 1630.06	Z9	RBF 1630	16	30	6	70	3,6	A10101630609						6		8		■
HFF 1630.08	Z3	RBF 1630	16	30	8	70	3,6	A10101630803	1	2	3	4			7			■
HFF 1630.08	Z9	RBF 1630	16	30	8	70	3,6	A10101630809						6		8		■



Base

Shape F, Arch round nose BASE-X

Ordering example: A10100313322

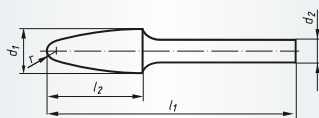

Packing unit:
10 pcs. per type,
from Ø 12 mm: 5 pcs. per type

Description	Cut	similar DIN 8033	d ₁ mm	l ₂ mm	d ₂ mm	l ₁ mm	r≈ mm	Product-Number	recommended for	New burrs
HFF 0313.03 BASE-X	ZX	RBF 0313	3	13	3	40	0,75	A10100313322	1 2 3 4 5 7	■
HFF 0618.06 BASE-X	ZX	RBF 0618	6	18	6	50	1,5	A10100618622	1 2 3 4 5 7	■
HFF 0820.06 BASE-X	ZX	---	8	20	6	60	1,8	A10100820622	1 2 3 4 5 7	■
HFF 1020.06 BASE-X	ZX	RBF 1020	10	20	6	60	2,5	A10101020622	1 2 3 4 5 7	■
HFF 1225.06 BASE-X	ZX	RBF 1225	12	25	6	65	2,5	A10101225622	1 2 3 4 5 7	■



Industry

Shape G, Arch pointed nose

Ordering example: A10040307305

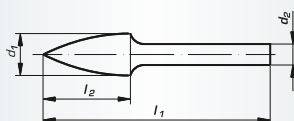

Packing unit:
1 pc. per type
Further dimensions, cuts and shank lengths on request.

Description	Cut	similar DIN 8033	d ₁ mm	l ₂ mm	d ₂ mm	l ₁ mm	Product-Number	recommended for	New burrs
HFG 0307.03	Z5	SPG 0307	3	7	3	40	A10040307305	1 2 3 4 7	■
HFG 0307.03	Z7	SPG 0307	3	7	3	40	A10040307308	1 2 3 5 7	■
HFG 0313.03	Z3	SPG 0313	3	13	3	40	A10040313303	1 2 3 4 7	■
HFG 0313.03	Z4	SPG 0313	3	13	3	40	A10040313304	2 3 4 7 8	■
HFG 0313.03	Z5	SPG 0313	3	13	3	40	A10040313305	1 2 3 4 7	■
HFG 0313.03	Z7	SPG 0313	3	13	3	40	A10040313308	1 2 3 5 7	■
HFG 0613.03	Z5	SPG 0613	6	13	3	43	A10040613305	1 2 3 4 7	■
HFG 0613.03	Z7	SPG 0613	6	13	3	43	A10040613308	1 2 3 5 7	■
HFG 0618.06	Z1	SPG 0618	6	18	6	50	A10040618601	6 8	■
HFG 0618.06	Z2	SPG 0618	6	18	6	50	A10040618602	1 5 6 8	■
HFG 0618.06	Z3	SPG 0618	6	18	6	50	A10040618603	1 2 3 4 7	■
HFG 0618.06	Z4	SPG 0618	6	18	6	50	A10040618604	2 3 4 7 8	■
HFG 0618.06	Z5	SPG 0618	6	18	6	50	A10040618605	1 2 3 4 7	■
HFG 0618.06	Z7	SPG 0618	6	18	6	50	A10040618608	1 2 3 5 7	■
HFG 0820.06	Z3	---	8	20	6	60	A10040820603	1 2 3 4 7	■
HFG 0820.06	Z7	---	8	20	6	60	A10040820608	1 2 3 5 7	■
HFG 1020.06	Z3	SPG 1020	10	20	6	60	A10041020603	1 2 3 4 7	■
HFG 1020.06	Z4	SPG 1020	10	20	6	60	A10041020604	2 3 4 7 8	■
HFG 1020.06	Z5	SPG 1020	10	20	6	60	A10041020605	1 2 3 4 7	■
HFG 1020.06	Z7	SPG 1020	10	20	6	60	A10041020608	1 2 3 5 7	■



Shape G, Arch pointed nose

Ordering example: A10041220603

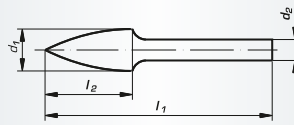

Packing unit:

1 pc. per type

Further dimensions, cuts and shank lengths on request.

Description	Cut	similar DIN 8033	d ₁ mm	l ₂ mm	d ₂ mm	l ₁ mm	Product-Number	recommended for	New burrs
HFG 1220.06	Z3	SPG 1220	12	20	6	60	A10041220603		■
HFG 1220.06	Z7	SPG 1220	12	20	6	60	A10041220608		■
HFG 1225.06	Z2	SPG 1225	12	25	6	65	A10041225602		■
HFG 1225.06	Z3	SPG 1225	12	25	6	65	A10041225603		■
HFG 1225.06	Z4	SPG 1225	12	25	6	65	A10041225604		■
HFG 1225.06	Z7	SPG 1225	12	25	6	65	A10041225608		■
HFG 1225.08	Z3	SPG 1225	12	25	8	65	A10041225803		■
HFG 1230.06	Z2	SPG 1230	12	30	6	70	A10041230602		■
HFG 1230.06	Z3	SPG 1230	12	30	6	70	A10041230603		■
HFG 1230.06	Z4	SPG 1230	12	30	6	70	A10041230604		■
HFG 1230.06	Z5	SPG 1230	12	30	6	70	A10041230605		■
HFG 1230.06	Z7	SPG 1230	12	30	6	70	A10041230608		■
HFG 1230.08	Z3	SPG 1230	12	30	8	70	A10041230803		■
HFG 1630.06	Z3	SPG 1630	16	30	6	70	A10041630603		■
HFG 1630.06	Z4	SPG 1630	16	30	6	70	A10041630604		■
HFG 1630.06	Z7	SPG 1630	16	30	6	70	A10041630608		■
HFG 1630.08	Z3	SPG 1630	16	30	8	70	A10041630803		■



Shape G, Arch pointed nose BASE-X

Ordering example: A10040313322

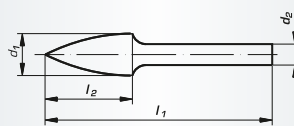

Packing unit:

10 pcs. per type,

from Ø 12 mm: 5 pcs. per type

Description	Cut	similar DIN 8033	d ₁ mm	l ₂ mm	d ₂ mm	l ₁ mm	Product-Number	recommended for	New burrs
HFG 0313.03 BASE-X	ZX	SPG 0313	3	13	3	40	A10040313322		■
HFG 0613.03 BASE-X	ZX	SPG 0613	6	13	3	43	A10040613322		■
HFG 0820.06 BASE-X	ZX	SPG 0820	8	20	6	60	A10040820622		■
HFG 1020.06 BASE-X	ZX	SPG 1020	10	20	6	60	A10041020622		■
HFG 1225.06 BASE-X	ZX	SPG 1225	12	25	6	65	A10041225622		■
HFG 1230.06 BASE-X	ZX	SPG 1230	12	30	6	65	A10041230622		■



Industry

Shape H, Flame

Ordering example: A10090307305

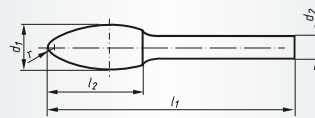

Packing unit:

1 pc. per type

Further dimensions, cuts and shank lengths on request.

Description	Cut	d ₁ mm	l ₂ mm	d ₂ mm	l ₁ mm	r ≈ mm	Product-Number	recommended for	New burrs
HFH 0307.03	Z5	3	7	3	40	0,8	A10090307305	① ② ③ ④ ⑦	■
HFH 0613.03	Z1	6	13	3	43	1,0	A10090613301	⑥ ⑧	■
HFH 0613.03	Z2	6	13	3	43	1,0	A10090613302	① ⑤ ⑥ ⑧	■
HFH 0613.03	Z3	6	13	3	43	1,0	A10090613303	① ② ③ ④ ⑦	■
HFH 0613.03	Z4	6	13	3	43	1,0	A10090613304	② ③ ④ ⑦ ⑧	■
HFH 0613.03	Z5	6	13	3	43	1,0	A10090613305	① ② ③ ④ ⑦	■
HFH 0613.03	Z7	6	13	3	43	1,0	A10090613308	① ② ③ ⑤ ⑦	■
HFH 0820.06	Z2	8	20	6	60	1,6	A10090820602	① ⑤ ⑥ ⑧	■
HFH 0820.06	Z3	8	20	6	60	1,6	A10090820603	① ② ③ ④ ⑦	■
HFH 0820.06	Z4	8	20	6	60	1,6	A10090820604	② ③ ④ ⑦ ⑧	■
HFH 0820.06	Z7	8	20	6	60	1,6	A10090820608	① ② ③ ⑤ ⑦	■
HFH 1230.06	Z3	12	30	6	70	2,0	A10091230603	① ② ③ ④ ⑦	■
HFH 1230.06	Z4	12	30	6	70	2,0	A10091230604	② ③ ④ ⑦ ⑧	■
HFH 1230.06	Z7	12	30	6	70	2,0	A10091230608	① ② ③ ⑤ ⑦	■
HFH 1230.08	Z3	12	30	8	70	2,0	A10091230803	① ② ③ ④ ⑦	■
HFH 1635.06	Z7	16	35	6	75	2,5	A10091635608	① ② ③ ⑤ ⑦	■
HFH 1635.08	Z3	16	35	8	75	2,5	A10091635803	① ② ③ ④ ⑦	■



Industry

Shape I, Internal burr with multi purpose cut

Ordering example: A10010204300

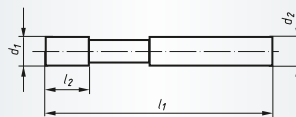

Packing unit:

1 pc. per type

Further dimensions, cuts and shank lengths on request.

Description	d ₁ mm	l ₂ mm	d ₂ mm	l ₁ mm	Product-Number	recommended for	New burrs
HFI 0204.03	2,5	4	3	40	A10010204300	③ ④ ⑦	■
HFI 0408.03	4	8	3	50	A10010408300	③ ④ ⑦	■
HFI 0610.06	6	10	6	65	A10010610600	③ ④ ⑦	■
HFI 0810.06	8	10	6	65	A10010810600	③ ④ ⑦	■



Shape J, Pointed nose

Ordering example: A10080660603

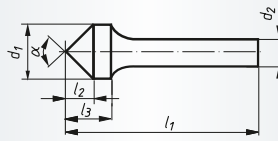

Packing unit:

1 pc. per type

Further dimensions, cuts and shank lengths on request.

Description	Cut	similar DIN 8033	d ₁ mm	l ₂ mm	l ₃ mm	d ₂ mm	l ₁ mm	α	Product-Number	recommended for	New burrs
HFJ 0605.06	Z3	KSJ 0605	6	5	-	6	50	60°	A10080660603	1 2 3 4 7	■
HFJ 1010.06	Z3	KSK 1005	10	5	10	6	50	90°	A10081090603	1 2 3 4 7	■
HFJ 1013.06	Z3	KSJ 1008	10	9	13	6	53	60°	A10081060603	1 2 3 4 7	■
HFJ 1613.06	Z3	KSK 1608	16	8	13	6	53	90°	A10081690603	1 2 3 4 7	■
HFJ 1613.08	Z3	KSK 1608	16	8	13	8	53	90°	A10081690803	1 2 3 4 7	■
HFJ 1616.06	Z3	KSJ 1613	16	14	16	6	56	60°	A10081660603	1 2 3 4 7	■
HFJ 1616.08	Z3	KSJ 1613	16	14	16	8	56	60°	A10081660803	1 2 3 4 7	■



Shape L, Conical Round nose

Ordering example: A10070820603

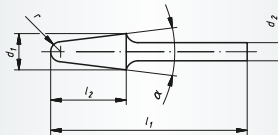

Packing unit:

1 pc. per type

Further dimensions, cuts and shank lengths on request.

Description	Cut	similar DIN 8033	d ₁ mm	l ₂ mm	d ₂ mm	l ₁ mm	r ≈ mm	α	Product-Number	recommended for	New burrs
HFL 0820.06	Z3	---	8	20	6	60	1,5	14°	A10070820603	1 2 3 4 7	■
HFL 0820.06	Z7	---	8	20	6	60	1,5	14°	A10070820608	1 2 3 5 7	■
HFL 0820.06	Z9	---	8	20	6	60	1,5	14°	A10070820609	6 8	■
HFL 1015.06	Z3	---	10	15	6	55	3,6	14°	A10071015603	1 2 3 4 7	■
HFL 1020.06	Z3	KEL 1020	10	20	6	60	2,9	14°	A10071020603	1 2 3 4 7	■
HFL 1020.06	Z7	KEL 1020	10	20	6	60	2,9	14°	A10071020608	1 2 3 5 7	■
HFL 1020.06	Z9	KEL 1020	10	20	6	60	2,9	14°	A10071020609	6 8	■
HFL 1225.06	Z3	KEL 1225	12	25	6	65	3,3	14°	A10071225603	1 2 3 4 7	■
HFL 1225.06	Z4	KEL 1225	12	25	6	65	3,3	14°	A10071225604	2 3 4 7 8	■
HFL 1225.06	Z7	KEL 1225	12	25	6	65	3,3	14°	A10071225608	1 2 3 5 7	■
HFL 1225.06	Z9	KEL 1225	12	25	6	65	3,3	14°	A10071225609	6 8	■
HFL 1225.08	Z3	KEL 1225	12	25	8	65	3,3	14°	A10071225803	1 2 3 4 7	■
HFL 1225.08	Z7	KEL 1225	12	25	8	65	3,3	14°	A10071225808	1 2 3 5 7	■
HFL 1230.06	Z1	KEL 1230	12	30	6	70	2,6	14°	A10071230601	6 8	■
HFL 1230.06	Z3	KEL 1230	12	30	6	70	2,6	14°	A10071230603	1 2 3 4 7	■
HFL 1230.06	Z4	KEL 1230	12	30	6	70	2,6	14°	A10071230604	2 3 4 7 8	■
HFL 1230.06	Z5	KEL 1230	12	30	6	70	2,6	14°	A10071230605	1 2 3 4 7	■
HFL 1230.06	Z7	KEL 1230	12	30	6	70	2,6	14°	A10071230608	1 2 3 5 7	■



Industry

Shape L, Conical Round nose

Ordering example: A10071230609

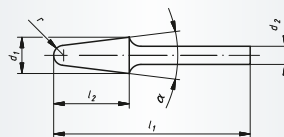

Packing unit:

1 pc. per type

Further dimensions, cuts and shank lengths on request.

Description	Cut	similar DIN 8033	d ₁ mm	l ₂ mm	d ₂ mm	l ₁ mm	r ≈ mm	α	Product-Number	recommended for	New burrs
HFL 1230.06	Z9	KEL 1230	12	30	6	70	2,6	14 °	A10071230609		■
HFL 1230.08	Z4	KEL 1230	12	30	8	70	2,6	14 °	A10071230804	2 3 4 7 8	■
HFL 1230.08	Z9	KEL 1230	12	30	8	70	2,6	14 °	A10071230809	6 8	■
HFL 1630.06	Z3	KEL 1630	16	30	6	70	4,8	14 °	A10071630603	1 2 3 4 7	■
HFL 1630.06	Z7	KEL 1630	16	30	6	70	4,8	14 °	A10071630608	1 2 3 5 7	■
HFL 1630.08	Z3	KEL 1630	16	30	8	70	4,8	14 °	A10071630803	1 2 3 4 7	■
HFL 1630.08	Z9	KEL 1630	16	30	8	70	4,8	14 °	A10071630809	6 8	■
HFL 2040.08	Z9	KEL 2040	20	40	8	80	5,5	14 °	A10072040809	6 8	■



Base

Shape L, Conical Round nose BASE-X

Ordering example: A10071230622

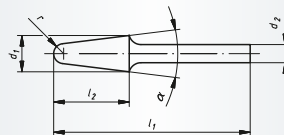

Packing unit:

10 pcs. per type,

from Ø 12 mm: 5 pcs. per type

Description	Cut	similar DIN 8033	d ₁ mm	l ₂ mm	d ₂ mm	l ₁ mm	r ≈ mm	α	Product-Number	recommended for	New burrs
HFL 1230.06 BASE-X	ZX	KEL 1230	12	30	6	70	2,6	14 °	A10071230622		■
										1 2 3 4 5 7	



Shape M, Conical Pointed nose

Ordering example: A10050307303

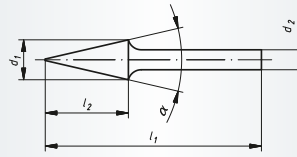

Packing unit:

1 pc. per type

Further dimensions, cuts and shank lengths on request.

Description	Cut	similar DIN 8033	d1 mm	l2 mm	d2 mm	l1 mm	α	Product-Number	recommended for								New burrs	
HFM 0307.03	Z3	SKM 0307	3	7	3	40	22°	A10050307303	1	2	3	4			7			■
HFM 0307.03	Z5	SKM 0307	3	7	3	40	22°	A10050307305	1	2	3	4			7			■
HFM 0307.03	Z7	SKM 0307	3	7	3	40	22°	A10050307308	1	2	3		5		7			■
HFM 0311.03	Z5	SKM 0311	3	11	3	40	14°	A10050311305	1	2	3	4			7			■
HFM 0311.03	Z7	SKM 0311	3	11	3	40	14°	A10050311308	1	2	3		5		7			■
HFM 0613.03	Z5	SKM 0613	6	13	3	43	25°	A10050613305	1	2	3	4			7			■
HFM 0613.03	Z7	SKM 0613	6	13	3	43	25°	A10050613308	1	2	3		5		7			■
HFM 0618.06	Z3	SKM 0618	6	18	6	50	16°	A10050618603	1	2	3	4			7			■
HFM 0618.06	Z4	SKM 0618	6	18	6	50	16°	A10050618604		2	3	4			7	8		■
HFM 0618.06	Z5	SKM 0618	6	18	6	50	16°	A10050618605	1	2	3	4			7			■
HFM 0618.06	Z7	SKM 0618	6	18	6	50	16°	A10050618608	1	2	3		5		7			■
HFM 0820.06	Z3	---	8	20	6	60	21°	A10050820603	1	2	3	4			7			■
HFM 0820.06	Z7	---	8	20	6	60	21°	A10050820608	1	2	3		5		7			■
HFM 1020.06	Z3	SKM 1020	10	20	6	60	27°	A10051020603	1	2	3	4			7			■
HFM 1020.06	Z4	SKM 1020	10	20	6	60	27°	A10051020604		2	3	4			7	8		■
HFM 1020.06	Z7	SKM 1020	10	20	6	60	27°	A10051020608	1	2	3		5		7			■
HFM 1020.08	Z3	---	10	20	8	60	27°	A10051020803	1	2	3	4			7			■
HFM 1225.06	Z1	SKM 1225	12	25	6	65	26°	A10051225601						6		8		■
HFM 1225.06	Z3	SKM 1225	12	25	6	65	26°	A10051225603	1	2	3	4			7			■
HFM 1225.06	Z4	SKM 1225	12	25	6	65	26°	A10051225604		2	3	4			7	8		■
HFM 1225.06	Z7	SKM 1225	12	25	6	65	26°	A10051225608	1	2	3		5		7			■
HFM 1225.08	Z3	SKM 1225	12	25	8	65	26°	A10051225803	1	2	3	4			7			■



Shape M, Conical Pointed nose BASE-X

Ordering example: A10050311322

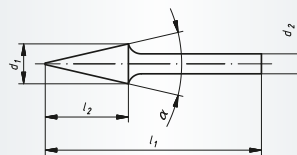
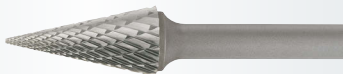

Packing unit:

10 pcs. per type,

from Ø 12 mm: 5 pcs. per type

Description	Cut	similar DIN 8033	d1 mm	l2 mm	d2 mm	l1 mm	α	Product-Number	recommended for								New burrs	
HFM 0311.03 BASE-X	ZX	SKM 0311	3	11	3	40	14°	A10050311322	1	2	3	4	5		7			■
HFM 0618.06 BASE-X	ZX	SKM 0618	6	18	6	50	16°	A10050618622	1	2	3	4	5		7			■
HFM 1020.06 BASE-X	ZX	SKM 1020	10	20	6	60	27°	A10051020622	1	2	3	4	5		7			■
HFM 1225.06 BASE-X	ZX	SKM 1225	12	25	6	65	26°	A10051225622	1	2	3	4	5		7			■



Industry

Shape N, Inverted cone

Ordering example: A10120307305

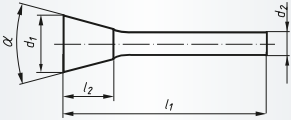
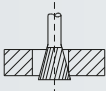

Description		Cut	similar DIN 8033	d ₁ mm	l ₂ mm	d ₂ mm	l ₁ mm	α	Product-Number	recommended for	New burrs
									Packing unit: 1 pc. per type Further dimensions, cuts and shank lengths on request.		
											
HFN 0307.03	Z5	WKN 0307	3	7	3	40	10°	A10120307305	1 2 3 4 7	■	
HFN 0307.03	Z7	WKN 0307	3	7	3	40	10°	A10120307308	1 2 3 5 7	■	
HFN 0607.03	Z5	WKN 0607	6	7	3	37	10°	A10120607305	1 2 3 4 7	■	
HFN 0607.06	Z3	WKN 0607	6	7	6	50	10°	A10120607603	1 2 3 4 7	■	
HFN 0607.06	Z4	WKN 0607	6	7	6	50	10°	A10120607604	2 3 4 7 8	■	
HFN 0607.06	Z5	WKN 0607	6	7	6	50	10°	A10120607605	1 2 3 4 7	■	
HFN 1013.06	Z3	WKN 1013	10	13	6	53	10°	A10121013603	1 2 3 4 7	■	
HFN 1013.06	Z4	WKN 1013	10	13	6	53	10°	A10121013604	2 3 4 7 8	■	
HFN 1213.06	Z3	WKN 1213	12	13	6	53	20°	A10121213603	1 2 3 4 7	■	
HFN 1213.06	Z4	WKN 1213	12	13	6	53	20°	A10121213604	2 3 4 7 8	■	
HFN 1613.08	Z3	WKN 1613	16	13	8	53	20°	A10121613803	1 2 3 4 7	■	
HFN 2013.06	Z4	---	20	13	6	53	30°	A10122013604	2 3 4 7 8	■	



Industry

Shape N, Inverted cone with end-cut

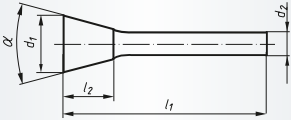
Ordering example: A101203073050001

Description		Cut	similar DIN 8033	d ₁ mm	l ₂ mm	d ₂ mm	l ₁ mm	α	Product-Number	recommended for	New burrs
									Packing unit: 1 pc. per type Further dimensions, cuts and shank lengths on request.		
											
HFNS 0307.03	Z5	WKN-S 0307	3	7	3	40	10°	A101203073050001	1 2 3 4 7	■	
HFNS 0307.03	Z7	WKN-S 0307	3	7	3	40	10°	A101203073080001	1 2 3 5 7	■	
HFNS 0607.03	Z5	WKN-S 0607	6	7	3	37	10°	A101206073050001	1 2 3 4 7	■	
HFNS 1013.06	Z3	WKN-S 1013	10	13	6	53	10°	A101210136030001	1 2 3 4 7	■	
HFNS 1013.06	Z4	WKN-S 1013	10	13	6	53	10°	A101210136040001	2 3 4 7 8	■	
HFNS 1213.06	Z3	WKN-S 1213	12	13	6	53	20°	A101212136030001	1 2 3 4 7	■	
HFNS 1213.06	Z4	WKN-S 1213	12	13	6	53	20°	A101212136040001	2 3 4 7 8	■	
HFNS 1613.06	Z4	WKN-S 1613	16	13	6	53	20°	A101216136040001	2 3 4 7 8	■	
HFNS 1613.08	Z3	WKN-S 1613	16	13	8	53	20°	A101216138030001	1 2 3 4 7	■	



Special milling cutters for machining of fibre reinforced materials and plastics

Ordering example: A101603133001

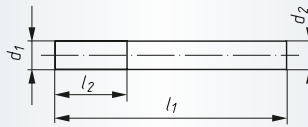

Packing unit:

1 pc. per type

Further dimensions, cuts and shank lengths on request.

Description	end cut	d ₁ mm	l ₂ mm	d ₂ mm	l ₁ mm	Product-Number	recommended for	New burrs
HFP 0313.03	01	3	13	3	40	A101603133001		■
HFP 0313.03	02	3	13	3	40	A101603133002		■
HFP 0313.03	03	3	13	3	40	A101603133003		■
HFP 0313.03	04	3	13	3	40	A101603133004		■
HFP 0416.04	02	4	16	4	50	A101604164002		■
HFP 0620.06	01	6	20	6	50	A101606206001		■
HFP 0620.06	02	6	20	6	50	A101606206002		■
HFP 0620.06	04	6	20	6	50	A101606206004		■
HFP 0825.08	01	8	25	8	80	A101608258001		■
HFP 0825.08	02	8	25	8	80	A101608258002		■
HFP 0825.08	04	8	25	8	80	A101608258004		■
HFP 1025.10	02	10	25	10	80	A101610251002		■
HFP 1025.10	04	10	25	10	80	A101610251004		■
HFP 1230.12	02	12	30	12	80	A101612301202		■

Type of end cut:



01 = no end cut



03 = double-flute



02 = multi-flute



04 = drill type, 120° tip angle

General information

Workpiece material properties:	GRP (glass fibre reinforced plastics) and CRP (carbon reinforced plastics) generally require machining where a high degree of specific strength and rigidity are required. Such particularly light materials should only be machined with special milling cutters which reduce the cutting pressure and prevent damage to the fibres in the material.
Market potential:	<ul style="list-style-type: none"> • Aerospace • Ship and yacht building • Model building • Automotive • Construction of wind turbines • Motor sport
Examples of application:	<ul style="list-style-type: none"> • Aircraft components • Pipes • Components for wind turbines • Applied off-hand or on stationary machines • Car components • Sport equipment
LUKAS-milling cutters:	The special milling tool in cut P has been developed solely for the use on CRP and GRP. The special flute geometry allows for precise machining – the choice of different face tooth geometry facilitates drilling (plunge) into the material or simply allows for an optimal facing application.



Engraving cutters of solid carbide single flute type

Ordering example: A13150030337102

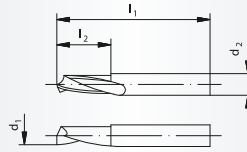

Packing unit:

1 pc. per type

Further dimensions, cuts and shank lengths on request.

Unless otherwise specified, the tolerances are as DIN 7468

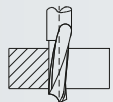
Description	d ₁ mm	l ₂ mm	d ₂ mm	l ₁ mm	Product-Number	recommended for	New burrs
HGE 0207.03	2	7	3	40	A13150030337102		■
HGE 0307.03	3	7	3	40	A13150030337103		■

Application: Very well suited for the machining of light metals, non-ferrous metals, plastics and for high-speed-machining of aluminium parts. Cutters with mirror finished flute to allow ideal chip removal and to avoid clogging.

Recommended cutting speeds

Main group of materials	Sub-group	Hardness (HB)	Strength (N/mm ²)	Optimal cutting speed (m/min)
Aluminium, Magnesium	Al, Mg non alloyed	≤ 100	≤ 350	≤ 400
	Al alloyed Si < 0,5%	≤ 150	≤ 500	≤ 400
	Al alloyed Si ≥ 0,5 < 10%	≤ 120	≤ 400	≤ 100
	Al alloyed Si ≥ 10%, Mg-all., Al-Whisker	≤ 120	≤ 400	≤ 70
	Plastics	Thermoplastics	–	–
	Thermo-setting plastics	–	–	–



Industry

Shape R, Trimming burr (external)

Ordering example: A10140812603

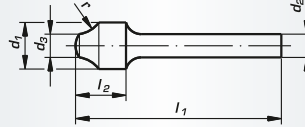

Packing unit:

1 pc. per type

Further dimensions, cuts and shank lengths on request.

Description	Cut	d ₁ mm	d ₃ mm	l ₂ mm	d ₂ mm	l ₁ mm	r ≈ mm	Product-Number	recommended for	New burrs
HFR 0812.06	Z3	8	3	12	6	52	2,5	A10140812603	1 2 3 4 7	■
HFR 1015.06	Z3	10	2	15	6	55	8	A10141015603	1 2 3 4 7	■
HFR 1215.06	Z3	12	6	15	6	55	8	A10141215603	1 2 3 4 7	■
HFR 1215.08	Z3	12	6	15	8	55	8	A10141215803	1 2 3 4 7	■
HFR 1315.06	Z3	13	3	15	6	55	10	A10141315603	1 2 3 4 7	■
HFR 1315.06	Z5	13	3	15	6	55	10	A10141315605	1 2 3 4 7	■
HFR 1315.08	Z3	13	3	15	8	55	10	A10141315803	1 2 3 4 7	■



Industry

Shape S, Trimming burr (internal)

Ordering example: A10131618803

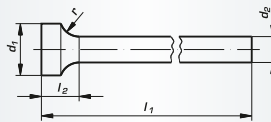

Packing unit:

1 pc. per type

Further dimensions, cuts and shank lengths on request.

Description	Cut	d ₁ mm	l ₂ mm	d ₂ mm	l ₁ mm	r ≈ mm	Product-Number	recommended for	New burrs
HFS 1618.08	Z3	16	12	8	120	6	A10131618803	1 2 3 4 7	■
HFS 1818.08	Z3	18	14	8	120	8	A10131818803	1 2 3 4 7	■
HFS 2218.08	Z3	22	16	8	120	10	A10132218803	1 2 3 4 7	■



Miniature burrs with multi-purpose cut

Ordering example: A10010104312

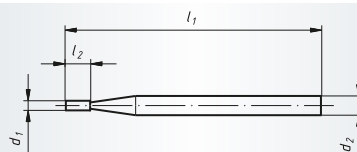

Packing unit:

1 pc. per type

Further dimensions, cuts and shank lengths on request.

Description	Shape	d ₁ mm	l ₂ mm	d ₂ mm	l ₁ mm	Product-Number	recommended for							New burrs		
							2	3	4	7	8	9	10			
HFA 01004.03		1	4	3	40	A10010104312	2	3	4		7					■
HFA 01504.03		1,5	4	3	40	A100101043120001	2	3	4		7					■
HFA 02004.03		2	4	3	40	A10010204312	2	3	4		7					■
HFC 01004.03		1	4	3	40	A10020104312	2	3	4		7					■
HFC 01504.03		1,5	4	3	40	A100201043120001	2	3	4		7					■
HFC 02004.03		2	4	3	40	A10020204312	2	3	4		7					■
HFD 01001.03		1	0,9	3	40	A10030101312	2	3	4		7					■
HFD 01501.03		1,5	1,35	3	40	A100301013120001	2	3	4		7					■
HFD 02002.03		2	1,8	3	40	A10030202312	2	3	4		7					■
HFE 01504.03		1,5	4	3	40	A10060104312	2	3	4		7					■
HFF 01504.03		1,5	4	3	40	A10100104312	2	3	4		7					■
HFG 01504.03		1,5	4	3	40	A10040104312	2	3	4		7					■
HFM 01504.03		1,5	4	3	40	A10050104312	2	3	4		7					■

Application:

- tool manufacture
- precision engineering
- jewellery industry
- turbine manufacture

Power Tool:

- We recommend our pneumatic grinder AMIN 72-013 GD, page 395

Materials to be processed:

- stainless steel
- CrNi alloys
- non-ferrous metals
- zinc diecasting
- soft ceramics
- titanium alloys

Useful hints:

- choose shortest overhang
- concentric running of the collet chuck is very important
- recommended speed: 70.000 rpm

Advantages:

- high dimensional accuracy
- minimal runout
- multi-purpose cut
- micro grain carbide
- precision ground cutting edges



Miniature burrs in cut 5, shank 3 mm

Ordering example: A10010210305

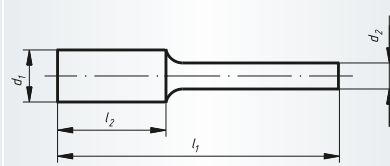

Packing unit:

1 pc. per type

Further dimensions, cuts and shank lengths on request.

Description	Cut	Shape	similar DIN 8033	Shank H = solid carbide S = Steel	d ₁ mm	l ₂ mm	l ₁ mm	Product-Number	recommended for	New burrs
HFA 0210.03	Z5		ZYA 0210	H	2	10	40	A10010210305	1 2 3 4 7	■
HFA 0313.03	Z5		ZYA 0313	H	3	13	40	A10010313305	1 2 3 4 7	■
HFA 0607.03	Z5		ZYA 0607	S	6	7	37	A10010607305	1 2 3 4 7	■
HFA 0613.03	Z5		ZYA 0613	S	6	13	43	A10010613305	1 2 3 4 7	■
HFAS 0210.03	Z5		ZYA-S 0210	H	2	10	40	A100102103050001	1 2 3 4 7	■
HFAS 0313.03	Z5		ZYA-S 0313	H	3	13	40	A100103133050001	1 2 3 4 7	■
HFAS 0607.03	Z5		ZYA-S 0607	S	6	7	37	A100106073050001	1 2 3 4 7	■
HFAS 0613.03	Z5		ZYA-S 0613	S	6	13	43	A100106133050001	1 2 3 4 7	■
HFC 0210.03	Z5		WRC 0210	H	2	10	40	A10020210305	1 2 3 4 7	■
HFC 0313.03	Z5		WRC 0313	H	3	13	40	A10020313305	1 2 3 4 7	■
HFC 0613.03	Z5		WRC 0613	S	6	13	43	A10020613305	1 2 3 4 7	■
HFD 0302.03	Z5		KUD 0302	H	3	2	40	A10030303305	1 2 3 4 7	■
HFD 0403.03	Z5		KUD 0403	H	4	3	34	A100304043050001	1 2 3 4 7	■
HFD 0605.03	Z5		KUD 0605	S	6	5	35	A10030606305	1 2 3 4 7	■
HFE 0307.03	Z5		TRE 0307	H	3	7	40	A10060307305	1 2 3 4 7	■
HFE 0610.03	Z5		TRE 0610	S	6	10	40	A10060610305	1 2 3 4 7	■
HFF 0307.03	Z5		RBF 0307	H	3	7	40	A10100307305	1 2 3 4 7	■
HFF 0313.03	Z5		RBF 0313	H	3	13	40	A10100313305	1 2 3 4 7	■
HFF 0613.03	Z5		RBF 0613	S	6	13	43	A10100613305	1 2 3 4 7	■
HFG 0307.03	Z5		SPG 0307	H	3	7	40	A10040307305	1 2 3 4 7	■
HFG 0313.03	Z5		SPG 0313	H	3	13	40	A10040313305	1 2 3 4 7	■
HFG 0613.03	Z5		SPG 0613	S	6	13	43	A10040613305	1 2 3 4 7	■
HFH 0307.03	Z5		---	H	3	7	40	A10090307305	1 2 3 4 7	■



Miniature burrs in cut 5, shank 3 mm

Ordering example: A10090613305

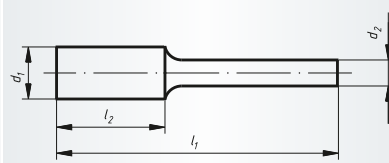

Packing unit:

1 pc. per type

Further dimensions, cuts and shank lengths on request.

* available only with fine cross-cut

Description	Cut	Shape	similar DIN 8033	Shank H = solid carbide S = Steel	d ₁ mm	l ₂ mm	l ₁ mm	Product-Number	recommended for										New burrs				
									1	2	3	4	5	6	7	8	9	10		11	12		
HFH 0613.03	Z5		---	S	6	13	43	A10090613305	1	2	3	4				7							■
HFI 0204.03	*		---	H	2,5	4	40	A10010204300	1	2	3	4				7							■
HFI 0408.03	*		---	H	4	8	50	A10010408300	1	2	3	4				7							■
HFM 0307.03	Z5		SKM 0307	H	3	7	40	A10050307305	1	2	3	4				7							■
HFM 0311.03	Z5		SKM 0311	H	3	11	40	A10050311305	1	2	3	4				7							■
HFM 0613.03	Z5		SKM 0613	S	6	13	43	A10050613305	1	2	3	4				7							■
HFN 0307.03	Z5		WKN 0307	H	3	7	40	A10120307305	1	2	3	4				7							■
HFN 0607.03	Z5		WKN 0607	S	6	7	37	A10120607305	1	2	3	4				7							■
HFNS 0307.03	Z5		WKN-S 0307	H	3	7	40	A101203073050001	1	2	3	4				7							■
HFNS 0607.03	Z5		WKN-S 0607	S	6	7	37	A101206073050001	1	2	3	4				7							■

54 Tungsten Carbide Burrs



Industry

Tool-sets, cut 7, shank 3 mm

Ordering example: A10390010



Packing unit:
1 pc. per type

Description	Shank Ø mm	Cut	Contents	1 pc. each	Product-Number	recommended for	
F10 S3	3	Z7	10-pieces	HFA 0313, HFA 0613, HFC 0313, HFC 0613, HFD 0302, HFD 0605, HFG 0313, HFG 0613, HFM 0613, HFF 0313	A10390010	<div style="display: flex; justify-content: space-around;"> 12357 </div>	■



Industry

Tool-sets, cut 7, shank 6 mm

Ordering example: A1039001006



Packing unit:
1 pc. per type

Description	Shank Ø mm	Cut	Contents	1 pc. each	Product-Number	recommended for	
F10 S6	6	Z7	10-pieces	HFAS 0616, HFAS 1225, HFC 0616, HFC 1225, HFD 0605, HFD 1210, HFG 0618, HFG 1225, HFF 0820, HFF 1225	A1039001006	<div style="display: flex; justify-content: space-around;"> 12357 </div>	■



Base

Tool-set, BASE-X, F5 S3

Ordering example: A10390053



Packing unit:
1 pc. per type

Description	Shank Ø mm	Cut	Contents	1 pc. each	Product-Number	recommended for	
F5 S3 BASE-X	3	ZX	5-pieces	HFA 0313, HFC 0313, HFD 0605, HFF 0313, HFG 0313	A10390053	1 2 3 4 5 7	■



Base

Tool-set, BASE-X, F5 S6

Ordering example: A10390056



Packing unit:
1 pc. per type

Description	Shank Ø mm	Cut	Contents	1 pc. each	Product-Number	recommended for	
F5 S6 BASE-X	6	ZX	5-pieces	HFA 1225, HFC 1225, HFD 1210, HFF 1225, HFG 1225	A10390056	1 2 3 4 5 7	■



Tungsten Carbide Burrs with TiAlN-coating*

Ordering example: A10010616608TIALN

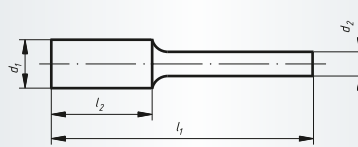

Packing unit:

1 pc. per type

Further dimensions, cuts and shank lengths on request.

Description	Shape	Cut	d ₁ mm	l ₂ mm	d ₂ mm	l ₁ mm	Product-Number	recommended for							New burrs
HFA 0616.06 Z7 TIALN		Z7	6	16	6	50	A10010616608TIALN	1	2	3	5	7			■
HFA 0820.06 Z7 TIALN		Z7	8	20	6	60	A10010820608TIALN	1	2	3	5	7			■
HFA 1020.06 Z7 TIALN		Z7	10	20	6	60	A10011020608TIALN	1	2	3	5	7			■
HFAS 0616.06 Z7 TIALN		Z7	6	16	6	50	A10010616608TIAL1	1	2	3	5	7			■
HFAS 0820.06 Z7 TIALN		Z7	8	20	6	60	A10010820608TIAL1	1	2	3	5	7			■
HFAS 1020.06 Z7 TIALN		Z7	10	20	6	60	A10011020608TIAL1	1	2	3	5	7			■
HFAS 1225.06 Z7 TIALN		Z7	12	25	6	65	A10011225608TIAL1	1	2	3	5	7			■
HFC 0616.06 Z7 TIALN		Z7	6	16	6	50	A10020616608TIALN	1	2	3	5	7			■
HFC 0820.06 Z7 TIALN		Z7	8	20	6	60	A10020820608TIALN	1	2	3	5	7			■
HFC 1020.06 Z7 TIALN		Z7	10	20	6	60	A10021020608TIALN	1	2	3	5	7			■
HFC 1225.06 Z7 TIALN		Z7	12	25	6	65	A10021225608TIALN	1	2	3	5	7			■
HFD 0605.06 Z7 TIALN		Z7	6	5	6	50	A10030606608TIALN	1	2	3	5	7			■
HFD 0807.06 Z7 TIALN		Z7	8	7	6	47	A10030808608TIALN	1	2	3	5	7			■
HFD 1009.06 Z7 TIALN		Z7	10	9	6	49	A10031010608TIALN	1	2	3	5	7			■
HFD 1210.06 Z7 TIALN		Z7	12	10	6	50	A10031210608TIALN	1	2	3	5	7			■
HFD 1614.06 Z7 TIALN		Z7	16	14	6	54	A10031614608TIALN	1	2	3	5	7			■
HFF 0618.06 Z7 TIALN		Z7	6	18	6	50	A10100618608TIALN	1	2	3	5	7			■
HFF 1225.06 Z7 TIALN		Z7	12	25	6	65	A10101225608TIALN	1	2	3	5	7			■
HFF 1630.06 Z7 TIALN		Z7	16	30	6	70	A10101630608TIALN	1	2	3	5	7			■
HFG 0618.06 Z7 TIALN		Z7	6	18	6	50	A10040618608TIALN	1	2	3	5	7			■
HFG 1020.06 Z7 TIALN		Z7	10	20	6	60	A10041020608TIALN	1	2	3	5	7			■
HFG 1225.06 Z7 TIALN		Z7	12	25	6	65	A10041225608TIALN	1	2	3	5	7			■
HFG 1630.06 Z7 TIALN		Z7	16	30	6	70	A10041630608TIALN	1	2	3	5	7			■
HFH 0820.06 Z7 TIALN		Z7	8	20	6	60	A10090820608TIALN	1	2	3	5	7			■
HFH 1230.06 Z7 TIALN		Z7	12	30	6	70	A10091230608TIALN	1	2	3	5	7			■
HFL 1020.06 Z7 TIALN		Z7	10	20	6	60	A10071020608TIALN	1	2	3	5	7			■
HFL 1230.06 Z7 TIALN		Z7	12	30	6	70	A10071230608TIALN	1	2	3	5	7			■
HFM 1020.06 Z7 TIALN		Z7	10	20	6	60	A10051020608TIALN	1	2	3	5	7			■

*High performance coating with a high degree of hardness and flow heat conductivity; therefore suitable for high thermal and mechanical applications; very low friction value

The reasons for producing Tungsten Carbide Burrs with TiAlN-coating are as follows:

- to increase tool life
- to reduce machining forces
- to improve chip removal



Tungsten Carbide Rasp burrs

Ordering example: A10021225618

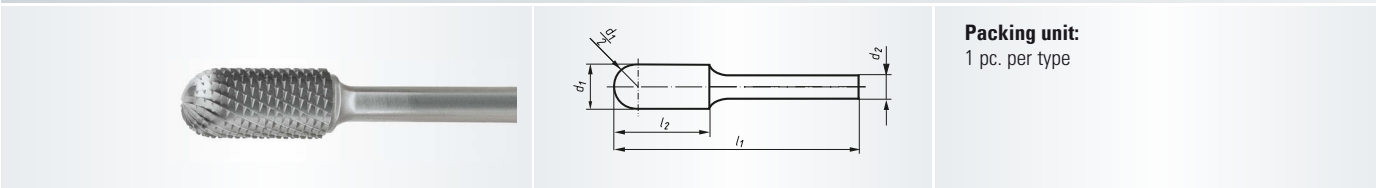

Packing unit:
1 pc. per type

Description	Cut	d1 mm	l2 mm	d2 mm	l1 mm	Product-Number	recommended for
HFC 1225.06	ZR2	12	25	6	65	A10021225618	① ■

Rasp burrs are manufactured from fine grit tungsten carbide and achieve a service life far exceeding that of comparable HSS or stippled burrs. A positive cutting geometry means that, even where only light force is applied, the burrs are very efficient during

cutting, achieving a high level of stock removal. In particular, when working with wood and other pattern construction materials, the desired contours can be achieved rapidly and accurately. Burrs and material remain cool and do not overheat.

Characteristics:

- Extremely aggressive, owing to a positive rake angle
- Long service life, owing to tungsten carbide
- Smooth running without vibration

Particularly suitable for:

- Pattern construction and wood
- Mould & die and cores
- Soft materials
- Composite materials

Example using Rasp burr with ZR2 cut

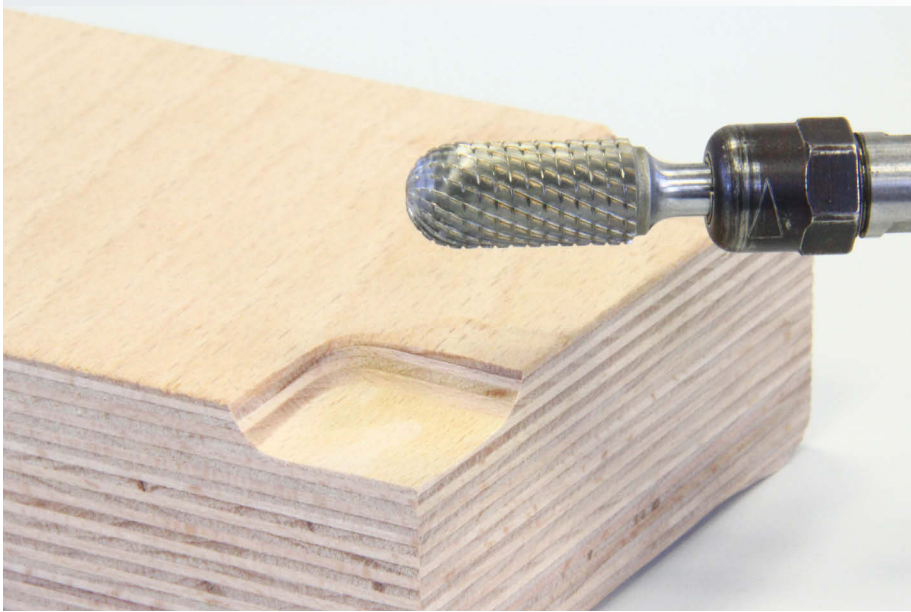



Tungsten Carbide Rotary files

Ordering example: A100106166150001

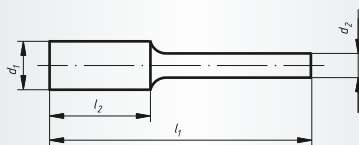

Packing unit:
1 pc. per type

Description	Cut	Shape	d ₁ mm	l ₂ mm	d ₂ mm	l ₁ mm	Product-Number	recommended for											
HFAS 0616.06	ZF2		6	16	6	50	A100106166150001	1	2	3	4	5	7						■
HFAS 0616.06	ZF3		6	16	6	50	A100106166140001	1	2	3	4	5	7						■
HFAS 1225.06	ZF1		12	25	6	65	A100112256160001	1	2	3	4	5	7						■
HFAS 1225.06	ZF2		12	25	6	65	A100112256150001	1	2	3	4	5	7						■
HFC 0616.06	ZF3		6	16	6	50	A10020616614	1	2	3	4	5	7						■
HFC 1225.06	ZF1		12	25	6	65	A10021225616	1	2	3	4	5	7						■
HFC 1225.06	ZF2		12	25	6	65	A10021225615	1	2	3	4	5	7						■
HFD 1009.06	ZF2		10	9	6	49	A10031009615	1	2	3	4	5	7						■
HFG 0618.06	ZF2		6	18	6	50	A10040618615	1	2	3	4	5	7						■
HFG 0618.06	ZF3		6	18	6	50	A10040618614	1	2	3	4	5	7						■
HFG 1230.06	ZF1		12	30	6	70	A10041230616	1	2	3	4	5	7						■
HFG 1230.06	ZF2		12	30	6	70	A10041230615	1	2	3	4	5	7						■
HFG 1230.06	ZF3		12	30	6	70	A10041230614	1	2	3	4	5	7						■
HFM 1225.06	ZF2		12	25	6	65	A10051225615	1	2	3	4	5	7						■

The micro-serration of the new tungsten carbide rotary files is based on the cutting geometry of a file and thus prevents clogging, even when removing soft materials. The precision cut is achieved on CNC grinding machines, thus ensuring perfect concentricity and chatter-free working. The burrs remain sharp for a long time as a result, achieving a clean surface finish free of chatter marks.

Rotary files are available in numerous sizes and shapes and three different cuts ranging from ZF1 (coarse) to ZF3 (fine). This means that the conditions of use can be optimised for each application with the result of the best surface finish.

Characteristics:

- Optimum surface finishes, owing to fine serration
- Long service life, owing to tungsten carbide
- No clogging

Particularly suitable for:

- Perfect surface finishes
- Composite materials
- Soft materials
- Bores



Industry

Burrs for machining non-ferrous metals, cut 9

Ordering example: A10010616609

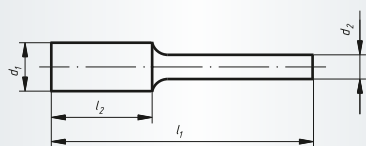

Packing unit:

1 pc. per type

Further dimensions, cuts and shank lengths on request.

Description	Cut	Shape	d ₁ mm	l ₂ mm	d ₂ mm	l ₁ mm	Product-Number	recommended for				New burrs		
								Al	St	Cu	Br			
HFA 0616.06	Z9		6	16	6	50	A10010616609					6	8	■
HFA 1225.06	Z9		12	25	6	65	A10011225609					6	8	■
HFA 1225.08	Z9		12	25	8	65	A10011225809					6	8	■
HFA 1625.06	Z9		16	25	6	65	A10011625609					6	8	■
HFA 1625.08	Z9		16	25	8	65	A10011625809					6	8	■
HFC 0616.06	Z9		6	16	6	50	A10020616609					6	8	■
HFC 0820.06	Z9		8	20	6	60	A10020820609					6	8	■
HFC 1225.06	Z9		12	25	6	65	A10021225609					6	8	■
HFC 1225.08	Z9		12	25	8	65	A10021225809					6	8	■
HFC 1625.06	Z9		16	25	6	65	A10021625609					6	8	■
HFC 1625.08	Z9		16	25	8	65	A10021625809					6	8	■
HFD 1210.06	Z9		12	10	6	50	A10031212609					6	8	■
HFD 1210.08	Z9		12	10	8	50	A10031212809					6	8	■
HFD 1614.06	Z9		16	14	6	54	A10031616609					6	8	■
HFD 1614.08	Z9		16	14	8	54	A10031616809					6	8	■
HFE 1225.08	Z9		12	25	8	65	A10061225809					6	8	■
HFE 1625.08	Z9		16	25	8	65	A10061625809					6	8	■
HFF 1225.06	Z9		12	25	6	65	A10101225609					6	8	■
HFF 1225.08	Z9		12	25	8	65	A10101225809					6	8	■
HFF 1630.06	Z9		16	30	6	70	A10101630609					6	8	■
HFF 1630.08	Z9		16	30	8	70	A10101630809					6	8	■
HFL 0820.06	Z9		8	20	6	60	A10070820609					6	8	■
HFL 1020.06	Z9		10	20	6	60	A10071020609					6	8	■
HFL 1225.06	Z9		12	25	6	65	A10071225609					6	8	■
HFL 1230.06	Z9		12	30	6	70	A10071230609					6	8	■
HFL 1230.08	Z9		12	30	8	70	A10071230809					6	8	■
HFL 1630.08	Z9		16	30	8	70	A10071630809					6	8	■
HFL 2040.08	Z9		20	40	8	80	A10072040809					6	8	■

Example using burr with Z9 cut





Burrs with extended shank length (shank length 200 mm)

Ordering example: A10011225603200

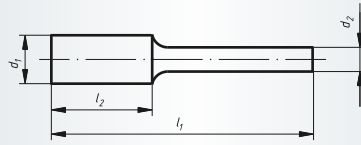

Packing unit:

1 pc. per type

Further dimensions, cuts and shank lengths on request.

Description	Shape	Cut	d ₁ mm	l ₂ mm	d ₂ mm	l ₁ mm	Product-Number	recommended for	New burrs
HFA 1225.06 L		Z3	12	25	6	225	A10011225603200	1 2 3 4 7	■
HFA 1225.06 L		Z7	12	25	6	225	A10011225608200	1 2 3 5 7	■
HFC 0616.06 L		Z3	6	16	6	216	A10020616603200	1 2 3 4 7	■
HFC 0616.06 L		Z7	6	16	6	216	A10020616608200	1 2 3 5 7	■
HFC 0820.06 L		Z3	8	20	6	220	A10020820603200	1 2 3 4 7	■
HFC 0820.06 L		Z7	8	20	6	220	A10020820608200	1 2 3 5 7	■
HFC 1020.06 L		Z7	10	20	6	220	A10021020608200	1 2 3 5 7	■
HFC 1225.06 L		Z7	12	25	6	225	A10021225608200	1 2 3 5 7	■
HFD 0605.06 L		Z3	6	5	6	205	A10030605603200	1 2 3 4 7	■
HFD 0605.06 L		Z7	6	5	6	205	A10030605608200	1 2 3 5 7	■
HFD 0807.06 L		Z3	8	7	6	207	A10030807603200	1 2 3 4 7	■
HFD 0807.06 L		Z7	8	7	6	207	A10030807608200	1 2 3 5 7	■
HFD 1009.06 L		Z3	10	9	6	209	A10031009603200	1 2 3 4 7	■
HFD 1009.06 L		Z7	10	9	6	209	A10031009608200	1 2 3 5 7	■
HFD 1210.06 L		Z3	12	10	6	210	A10031210603200	1 2 3 4 7	■
HFD 1210.06 L		Z7	12	10	6	210	A10031210608200	1 2 3 5 7	■
HFD 1210.08 L		Z3	12	10	8	210	A10031210803200	1 2 3 4 7	■
HFD 1210.08 L		Z7	12	10	8	210	A10031210808200	1 2 3 5 7	■
HFE 1220.06 L		Z3	12	20	6	220	A10061220603200	1 2 3 4 7	■
HFE 1220.06 L		Z7	12	20	6	220	A10061220608200	1 2 3 5 7	■
HFE 1220.08 L		Z7	12	20	8	220	A10061220808200	1 2 3 5 7	■
HFF 0618.06 L		Z3	6	18	6	218	A10100618603200	1 2 3 4 7	■
HFF 0618.06 L		Z7	6	18	6	218	A10100618608200	1 2 3 5 7	■
HFF 1230.08 L		Z3	12	30	8	230	A10101230803200	1 2 3 4 7	■
HFF 1230.08 L		Z7	12	30	8	230	A10101230808200	1 2 3 5 7	■
HFG 0618.06 L		Z3	6	18	6	218	A10040618603200	1 2 3 4 7	■
HFG 0618.06 L		Z7	6	18	6	218	A10040618608200	1 2 3 5 7	■
HFG 1230.08 L		Z7	12	30	8	230	A10041230808200	1 2 3 5 7	■
HFH 1020.06 L		Z3	10	20	6	220	A10091020603200	1 2 3 4 7	■
HFH 1020.06 L		Z7	10	20	6	220	A10091020608200	1 2 3 5 7	■
HFH 1230.08 L	Z7	12	30	8	230	A10091230808200	1 2 3 5 7	■	

Safety instructions: Recommended operating speed for major exposed shank lengths

In order to avoid the risk of accidents, it is necessary to ensure contact between the tool and workpiece prior to starting the power tool, or to insert the tool into bores or channels. Contact with the workpiece must be ensured until the machine is deactivated. If permanent contact with the workpiece cannot be ensured, the machine should run at idling speed.

Reduced speeds for tungsten carbide burrs with extra long shank (200 mm)

Tool diameter d ₁ mm	6	8	10	12	12
Shank diameter d ₂ mm	6	6	6	6	8
Maximum idling speed without workpiece contact (1/min)	4.000	3.200	2.800	2.200	3.600
Recommended reduced operating speed with workpiece contact (1/min)	13.000	10.000	8.000	7.000	7.000



Base

Tungsten Carbide Burrs with Imperial-Sized Shanks, BASE-X

Ordering example: A5001082062214

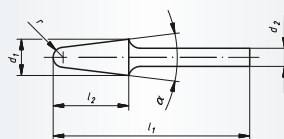

Packing unit:
10 pcs. per type,
from Ø 12 mm: 5 pcs. per type

Description	Cut	Shape	similar DIN 8033	d ₁ mm	l ₂ mm	d ₂ mm	l ₁ mm	α	r ≈ mm	Product-Number	recommended for	New burrs
HFA 0820.06 BASE-X	ZX		ZYA 8020	8	20	1/4"	60			A5001082062214	1 2 3 4 5 7	■
HFA 1020.06 BASE-X	ZX		ZYA 1020	10	20	1/4"	60			A5001102062214	1 2 3 4 5 7	■
HFA 1225.06 BASE-X	ZX		ZYA 1225	12	25	1/4"	65			A5001122562214	1 2 3 4 5 7	■
HFC 0616.06 BASE-X	ZX		WRC 0616	6	16	1/4"	50			A5002061662214	1 2 3 4 5 7	■
HFC 0820.06 BASE-X	ZX		WRC 0820	8	20	1/4"	60			A5002082062214	1 2 3 4 5 7	■
HFC 1020.06 BASE-X	ZX		WRC 1020	10	20	1/4"	60			A5002102062214	1 2 3 4 5 7	■
HFC 1225.06 BASE-X	ZX		WRC 1225	12	25	1/4"	65			A5002122562214	1 2 3 4 5 7	■
HFD 1009.06 BASE-X	ZX		KUD 1009	10	9	1/4"	49			A5003100962214	1 2 3 4 5 7	■
HFD 1210.06 BASE-X	ZX		KUD 1210	12	10	1/4"	51			A5003121062214	1 2 3 4 5 7	■
HFF 0820.06 BASE-X	ZX		-	8	20	1/4"	60		1,8	A5010082062214	1 2 3 4 5 7	■
HFF 1020.06 BASE-X	ZX		RBF 1020	10	20	1/4"	60		2,5	A5010102062214	1 2 3 4 5 7	■
HFF 1225.06 BASE-X	ZX		RBF 1225	12	25	1/4"	65		2,5	A5010122562214	1 2 3 4 5 7	■
HFG 0820.06 BASE-X	ZX		SPG 8020	8	20	1/4"	60			A5004082062214	1 2 3 4 5 7	■
HFG 1020.06 BASE-X	ZX		SPG 1020	10	20	1/4"	60			A5004102062214	1 2 3 4 5 7	■
HFG 1225.06 BASE-X	ZX		SPG 1225	12	25	1/4"	65			A5004122562214	1 2 3 4 5 7	■
HFG 1230.06 BASE-X	ZX		SPG 1230	12	30	1/4"	70			A5004123062214	1 2 3 4 5 7	■
HFL 1230.06 BASE-X	ZX		KEL 1230	12	30	1/4"	70	14°	2,6	A5007123062214	1 2 3 4 5 7	■
HFM 0618.06 BASE-X	ZX		SKM 0618	6	18	1/4"	50	16°		A5005061862214	1 2 3 4 5 7	■
HFM 1020.06 BASE-X	ZX		SKM 1020	10	20	1/4"	60	27°		A5005102062214	1 2 3 4 5 7	■
HFM 1225.06 BASE-X	ZX		SKM 1225	12	25	1/4"	65	26°		A5005122562214	1 2 3 4 5 7	■



Tools for stationary use

	<p>Range of application:</p> <ul style="list-style-type: none"> • Tool construction • Turbine construction • Aircraft and space industry • general machine tool construction 	<p>In addition to rotary burrs, we also produce tungsten carbide milling tools in special shapes and sizes for stationary application.</p> <p>We supply these milling cutters with a diameter of 12 mm maximum diameter and with a maximum length of 250 mm; they differ from our extensive standard range by the shape, tool material and geometry (rake, relief and helix angles).</p>
---	---	--

--	--

<p>Differential drill, radius mill, shank-end mill, die mill, profile mill</p>	<p>delivery on request</p>
--	----------------------------



Tools for hand-held and floor-stand application

	<p>Range of application:</p> <ul style="list-style-type: none"> • general machine tool construction • shipbuilding 	
---	---	--

--	--

<p>Trimming burr</p>	<p>delivery on request</p>
----------------------	----------------------------

Burrs of HSS

- 64 Technical Information

- 65 A summary of available shapes

- 67 Types of cut and their application

- 68 Burrs of HSS

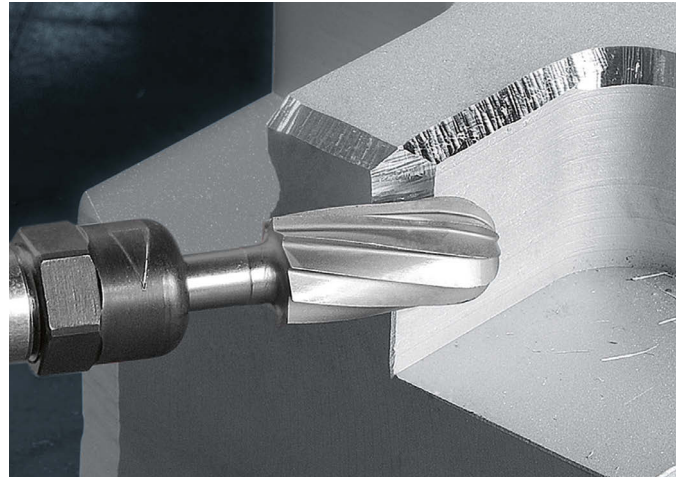

Product line marking

Product lines are labelled in the table header with the appropriate tabs. Further information on page **14** and **15**.



Technical Information

Quality

LUKAS HSS burrs are manufactured from high quality and well-proven HSS. Our automatic flute grinding machines and our own heat treatment plant guarantee a top quality product.

Application

Providing the correct type and speed are used, LUKAS HSS burrs will economically machine a wide variety of materials. Regarding cutting speeds, please refer to the table on page **66** or according to the table illustrating the various cuts on page **67**. A rule of thumb: Coarse cuts for soft materials – fine cuts for hard materials.

Power tools

LUKAS HSS burrs can be used on any air or electric powered machines. To achieve the optimal performance, the machines must be run at the correct speed, the collets must run true, and the bearings to be in good condition.

Shanks

Standard shank length is 40 mm. To reach inaccessible working areas, extra long shanks are available on request.









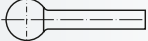
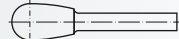

Packaging

Depending on burr dimension and quantity ordered, we choose the most appropriate packing method from our environmentally-friendly unit packs (5 or 10 pieces).

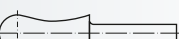
Special tools

We can manufacture HSS burrs to your design and drawing and guarantee the usual high quality LUKAS standard.

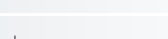
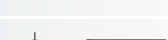
A summary of available shapes

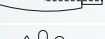
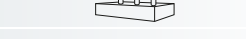
Shape	Type	Shape (LUKAS)	Page
	Cylindrical	A	68
	Cylindrical round nose	C	70
	Spherical	D	70
	Oval	E	71
	Arch pointed nose	G	72
	Flame	H	73
	Club	K	73
	Conical round nose	L	74
	Conical pointed nose	M	74
	Inverted cone	N	75
	Edge trimming burr	W	75
	Miniature Burrs, Shank 3 mm		76
	Miniature Burrs, Shank 6 mm		78
	Burrs with internal thread		79
	Tools sets		81
	Power Tools		381

Three steps to your optimum burr:

- 1 Select the **material** and **machining mode** (coarse to fine) from the table and
- 2 read off the recommended **cut** and **cutting speed**.
- 3 Determine the appropriate **speed** for your power tool in the second table.

Recommendations for use burrs of HSS

1				2		
Material	Lukas material group (see also fold-out tab)	Strength [N/mm ²]	Machining	Cut	Recommended cutting speed vc [m/min]	
Steel, cast steel	1 STEEL AND CAST STEEL	< 800	coarse	Z2	50 – 100	
			medium	Z3	100 – 200	
			fine	Z5	50 – 200	
	2 ALLOYED/HARDENED & TEMPERED STEELS	800 to 1200	coarse	Z2	50 – 100	
			medium	Z3	100 – 200	
			fine	Z5	50 – 200	
Non-ferrous metal 1	6 ALUMINIUM, MAGNESIUM AND COPPER ALLOYS	up to 450	coarse	Z1	200 – 300	
			medium	Z2	150 – 300	
Plastics and wood	8 PLASTIC/WOOD/RUBBER	20 to 400	coarse	Z1	200 – 300	
			fine	Z2	150 – 300	

Rotational speeds for milling tools based on the tool diameter and cutting speed

3							
Recommended cutting speed vc [m/min]							
		50	100	150	200	250	300
		Rotational speed [min ⁻¹]					
Tool diameter [mm]	2	8.000	16.000	24.000	32.000	40.000	48.000
	3	5.000	11.000	16.000	21.000	27.000	32.000
	4	4.000	8.000	12.000	16.000	20.000	24.000
	6	3.000	5.000	8.000	11.000	13.000	16.000
	8	2.000	4.000	6.000	8.000	10.000	12.000
	10	2.000	3.000	5.000	6.000	8.000	10.000
	12	1.000	3.000	4.000	5.000	7.000	8.000
	16	1.000	2.000	3.000	4.000	5.000	6.000
	20	1.000	2.000	2.000	3.000	4.000	5.000
	22	1.000	1.000	2.000	3.000	4.000	4.000
	25	1.000	1.000	2.000	3.000	3.000	4.000
	30	1.000	1.000	2.000	2.000	3.000	3.000
	35	–	1.000	1.000	2.000	2.000	3.000

Please see page 381 to 396 for appropriate power tools.

Tip: Page 65 contains a complete overview of the shapes for your chosen milling tool.

Machining



Cuts

	Z 1	Coarse cut for soft materials		Z 3	Medium single cut
	Z 2	Robust single cut for high stock removal		Z 5	Very fine single cut for high-quality surfaces

Choosing the appropriate Burr

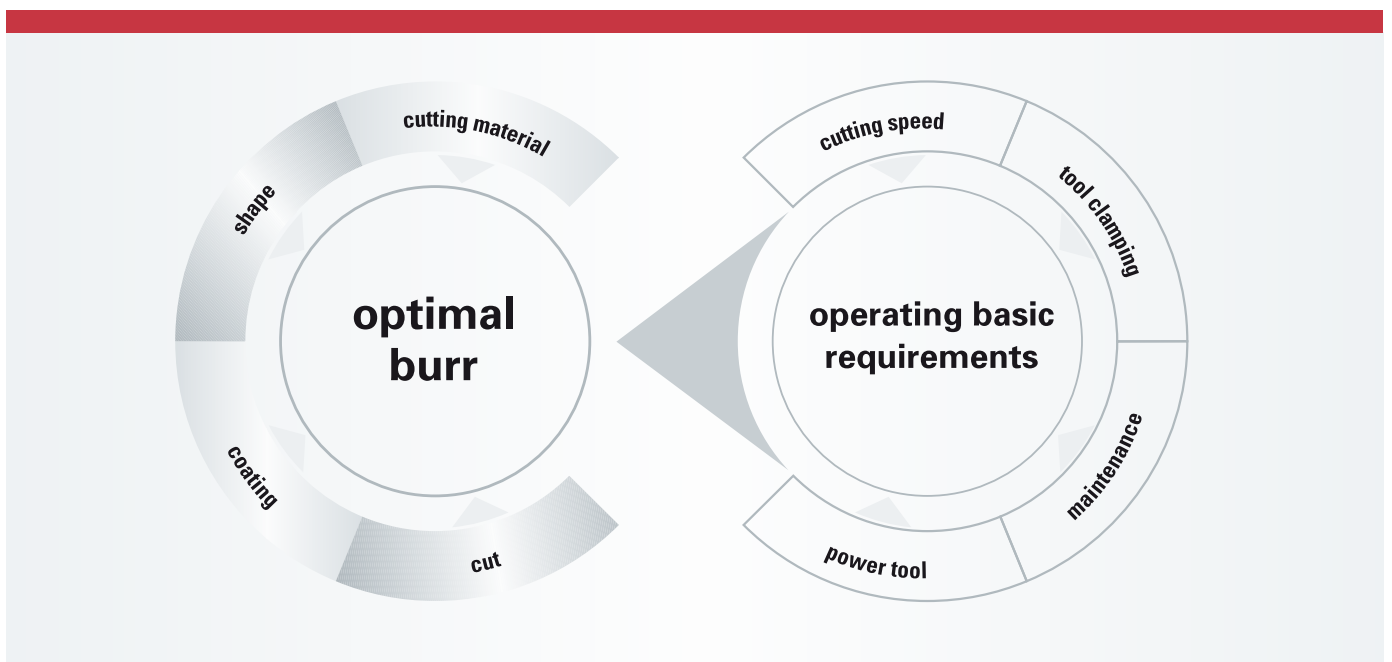



Shape A, Cylindrical

Ordering example: A12000304605

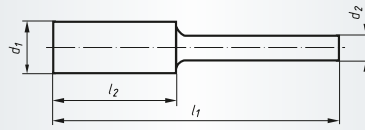

Packing unit:

up to d₁ 10 mm = 10 pc. per type
from d₁ 12 mm = 5 pc. per type

Further dimensions, cuts and shank lengths on request.

Description	Cut	d ₁ mm	l ₂ mm	l ₁ mm	d ₂ mm	Product-Number	recommended for										New burrs				
							1	2	3	4	5	6	7	8	9	10					
MFA 0304.06	Z5	3	4,5	60	6	A12000304605	1	2					6								■
MFA 0607.06	Z5	6	7	60	6	A12000607605	1	2					6								■
MFA 0616.06	Z1	6	16	56	6	A12000616601							6		8						■
MFA 0616.06	Z2	6	16	56	6	A12000616602							6		8						■
MFA 0616.06	Z3	6	16	56	6	A12000616603	1	2													■
MFA 0616.06	Z5	6	16	56	6	A12000616605	1	2					6								■
MFA 0820.06	Z3	8	20	60	6	A12000820603	1	2													■
MFA 1013.06	Z2	10	13	53	6	A12001013602							6		8						■
MFA 1013.06	Z3	10	13	53	6	A12001013603	1	2													■
MFA 1020.06	Z3	10	20	60	6	A12001020603	1	2													■
MFA 1225.06	Z1	12	25	65	6	A12001225601							6		8						■
MFA 1225.06	Z2	12	25	65	6	A12001225602							6		8						■
MFA 1225.06	Z3	12	25	65	6	A12001225603	1	2													■
MFA 1225.06	Z5	12	25	65	6	A12001225605	1	2					6								■
MFA 1625.06	Z1	16	25	65	6	A12001625601							6		8						■
MFA 1625.06	Z2	16	25	65	6	A12001625602							6		8						■
MFA 1625.06	Z3	16	25	65	6	A12001625603	1	2													■



Industry

Shape A, Cylinder with end-cut

Ordering example: A120006166010001

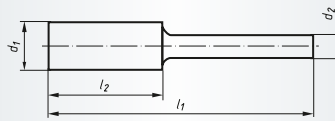

Packing unit:

up to d₁ 10 mm = 10 pc. per type
from d₁ 12 mm = 5 pc. per type

Further dimensions, cuts and shank lengths on request.

Description	Cut	d ₁ mm	l ₂ mm	l ₁ mm	d ₂ mm	Product-Number	recommended for										New burrs					
MFAS 0616.06	Z1	6	16	56	6	A120006166010001											6	8			■	
MFAS 0616.06	Z2	6	16	56	6	A120006166020001											6	8			■	
MFAS 0616.06	Z3	6	16	56	6	A120006166030001	1	2														■
MFAS 0616.06	Z5	6	16	56	6	A120006166050001	1	2								6						■
MFAS 0820.06	Z3	8	20	60	6	A120008206030001	1	2														■
MFAS 1013.06	Z2	10	13	53	6	A120010136020001											6	8			■	
MFAS 1013.06	Z3	10	13	53	6	A120010136030001	1	2														■
MFAS 1225.06	Z1	12	25	65	6	A120012256010001											6	8			■	
MFAS 1225.06	Z2	12	25	65	6	A120012256020001											6	8			■	
MFAS 1225.06	Z3	12	25	65	6	A120012256030001	1	2														■
MFAS 1625.06	Z1	16	25	65	6	A120016256010001											6	8			■	
MFAS 1625.06	Z2	16	25	65	6	A120016256020001											6	8			■	
MFAS 1625.06	Z3	16	25	65	6	A120016256030001	1	2														■



Industry

Shape C, Round nose

Ordering example: A12010304605

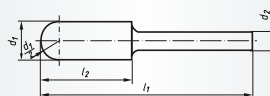

Packing unit:

up to d₁ 10 mm = 10 pc. per type
from d₁ 12 mm = 5 pc. per type

Further dimensions, cuts and shank lengths on request.

Description	Cut	d ₁ mm	l ₂ mm	l ₁ mm	d ₂ mm	Product-Number	recommended for	New burrs
MFC 0304.06	Z5	3	4,5	60	6	A12010304605	① ② ⑥	■
MFC 0620.06	Z1	6	20	60	6	A12010620601	⑥ ⑧	■
MFC 0620.06	Z2	6	20	60	6	A12010620602	⑥ ⑧	■
MFC 0620.06	Z3	6	20	60	6	A12010620603	① ②	■
MFC 0620.06	Z5	6	20	60	6	A12010620605	① ② ⑥	■
MFC 0820.06	Z3	8	20	60	6	A12010820603	① ②	■
MFC 0850.06	Z1	8	50	90	6	A12010850601	⑥ ⑧	■
MFC 0850.06	Z2	8	50	90	6	A12010850602	⑥ ⑧	■
MFC 1020.06	Z3	10	20	60	6	A12011020603	① ②	■
MFC 1225.06	Z1	12	25	65	6	A12011225601	⑥ ⑧	■
MFC 1225.06	Z2	12	25	65	6	A12011225602	⑥ ⑧	■
MFC 1225.06	Z3	12	25	65	6	A12011225603	① ②	■
MFC 1225.06	Z5	12	25	65	6	A12011225605	① ② ⑥	■



Industry

Shape D, Spherical

Ordering example: A12050303603

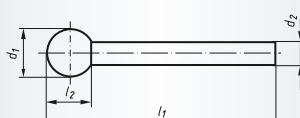

Packing unit:

up to d₁ 10 mm = 10 pc. per type
from d₁ 12 mm = 5 pc. per type

Further dimensions, cuts and shank lengths on request.

Description	Cut	d ₁ mm	l ₂ mm	d ₂ mm	l ₁ mm	Product-Number	recommended for	New burrs
MFD 0302.06	Z3	3	2	6	60	A12050303603	① ②	■
MFD 0303.06	Z3	3,5	3	6	60	A120503036030001	① ②	■
MFD 0403.06	Z3	4	3	6	60	A12050404603	① ②	■
MFD 0404.06	Z2	4,5	4	6	60	A120504046020001	⑥ ⑧	■
MFD 0404.06	Z3	4,5	4	6	60	A120504046030001	① ②	■
MFD 0504.06	Z3	5	4	6	60	A12050505603	① ②	■
MFD 0605.06	Z2	6	5	6	60	A12050606602	⑥ ⑧	■
MFD 0605.06	Z3	6	5	6	60	A12050606603	① ②	■
MFD 0807.06	Z1	8	7	6	60	A12050808601	⑥ ⑧	■
MFD 0807.06	Z2	8	7	6	60	A12050808602	⑥ ⑧	■
MFD 0807.06	Z3	8	7	6	60	A12050808603	① ②	■
MFD 0807.06	Z5	8	7	6	60	A12050808605	① ② ⑥	■



Industry

Shape D, Spherical

Ordering example: A12051010602

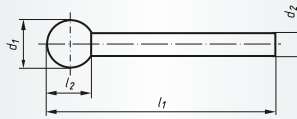

Packing unit:

up to d_1 10 mm = 10 pc. per type
 from d_1 12 mm = 5 pc. per type
 Further dimensions, cuts and shank lengths on request.

Description	Cut	d_1 mm	l_2 mm	d_2 mm	l_1 mm	Product-Number	recommended for								New burrs				
							1	2	3	4	5	6	7	8		9	10		
MFD 1009.06	Z2	10	9	6	60	A12051010602							6			8			■
MFD 1009.06	Z3	10	9	6	60	A12051010603	1	2											■
MFD 1009.06	Z5	10	9	6	60	A12051010605	1	2					6						■
MFD 1210.06	Z1	12	10	6	60	A12051212601							6			8			■
MFD 1210.06	Z2	12	10	6	60	A12051212602							6			8			■
MFD 1210.06	Z3	12	10	6	60	A12051212603	1	2											■
MFD 1614.06	Z1	16	14	6	60	A12051614601							6			8			■
MFD 1614.06	Z2	16	14	6	60	A12051614602							6			8			■
MFD 1614.06	Z3	16	14	6	60	A12051614603	1	2											■



Industry

Shape E, Oval

Ordering example: A12080607605

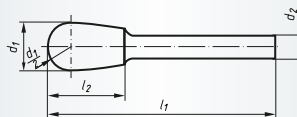

Packing unit:

up to d_1 10 mm = 10 pc. per type
 from d_1 12 mm = 5 pc. per type
 Further dimensions, cuts and shank lengths on request.

Description	Cut	d_1 mm	l_2 mm	d_2 mm	l_1 mm	Product-Number	recommended for								New burrs				
							1	2	3	4	5	6	7	8		9	10		
MFE 0607.06	Z5	6	7	6	60	A12080607605	1	2					6						■
MFE 1220.06	Z1	12	20	6	60	A12081220601							6			8			■
MFE 1220.06	Z3	12	20	6	60	A12081220603	1	2											■
MFE 1625.06	Z1	16	25	6	60	A12081625601							6			8			■
MFE 1625.06	Z2	16	25	6	60	A12081625602							6			8			■
MFE 1625.06	Z3	16	25	6	60	A12081625603	1	2											■



Shape G, Arch pointed nose

Ordering example: A12060618601

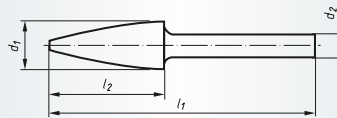

Packing unit:

up to d_1 10 mm = 10 pc. per type
 from d_1 12 mm = 5 pc. per type

Further dimensions, cuts and shank lengths on request.

Description	Cut	d ₁ mm	l ₂ mm	d ₂ mm	l ₁ mm	Product-Number	recommended for										New burrs			
MFG 0618.06	Z1	6	18	6	58	A12060618601												6	8	■
MFG 0618.06	Z2	6	18	6	58	A12060618602												6	8	■
MFG 0618.06	Z3	6	18	6	58	A12060618603	1	2												■
MFG 1220.06	Z1	12	20	6	60	A12061220601												6	8	■
MFG 1220.06	Z2	12	20	6	60	A12061220602												6	8	■
MFG 1220.06	Z3	12	20	6	60	A12061220603	1	2												■
MFG 1225.06	Z3	12	25	6	65	A12061225603	1	2												■
MFG 1230.06	Z1	12	30	6	70	A12061230601												6	8	■
MFG 1230.06	Z2	12	30	6	70	A12061230602												6	8	■
MFG 1230.06	Z3	12	30	6	70	A12061230603	1	2												■
MFG 1230.06	Z5	12	30	6	70	A12061230605	1	2										6		■
MFG 1630.06	Z1	16	30	6	70	A12061630601												6	8	■
MFG 1630.06	Z2	16	30	6	70	A12061630602												6	8	■
MFG 1630.06	Z3	16	30	6	70	A12061630603	1	2												■
MFG 1630.06	Z5	16	30	6	70	A12061630605	1	2										6		■



Industry

Shape H, Flame

Ordering example: A12070305605

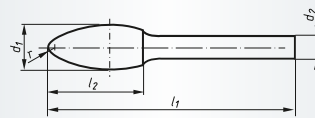

Packing unit:

up to d_1 10 mm = 10 pc. per type
 from d_1 12 mm = 5 pc. per type
 Further dimensions, cuts and shank lengths on request.

Description	Cut	d_1 mm	l_2 mm	d_2 mm	l_1 mm	$r \approx$ mm	Product-Number	recommended for	New burrs
MFH 0305.06	Z5	3	5	6	60	--	A12070305605		■
MFH 0820.06	Z3	8	20	6	60	1,3	A12070820603		■
MFH 1230.06	Z3	12	30	6	70	1,9	A12071230603		■
MFH 1635.06	Z3	16	35	6	75	2,4	A12071635603		■
MFH 1750.08	Z1	17	50	8	80	--	A12071750801		■



Industry

Shape K, Club

Ordering example: A12090620602

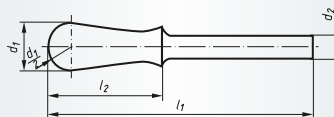

Packing unit:

up to d_1 10 mm = 10 pc. per type
 from d_1 12 mm = 5 pc. per type
 Further dimensions, cuts and shank lengths on request.

Description	Cut	d_1 mm	l_2 mm	d_2 mm	l_1 mm	Product-Number	recommended for	New burrs
MFK 0620.06	Z2	6	20	6	60	A12090620602		■
MFK 0620.06	Z3	6	20	6	60	A12090620603		■
MFK 1230.06	Z2	12	30	6	70	A12091230602		■
MFK 1230.06	Z3	12	30	6	70	A12091230603		■



Industry

Shape N, Inverted cone

Ordering example: A12040303605

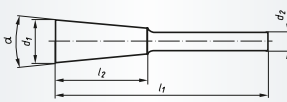
							<p>Packing unit: up to d₁ 10 mm = 10 pc. per type from d₁ 12 mm = 5 pc. per type Further dimensions, cuts and shank lengths on request.</p>												
Description	Cut	d ₁ mm	l ₂ mm	d ₂ mm	l ₁ mm	α	Product-Number	recommended for								New burrs			
MFN 0303.06	Z5	3	3	6	60	20°	A12040303605	1	2					6					■
MFN 0606.06	Z5	6	6	6	60	20°	A12040606605	1	2					6					■
MFN 1213.06	Z1	12	13	6	53	17°	A12041213601							6		8			■
MFN 1213.06	Z3	12	13	6	53	17°	A12041213603	1	2										■
MFN 1230.06	Z3	12	30	6	70	8°	A12041230603	1	2										■



Industry

Shape N, Inverted cone with end-cut

Ordering example: A120412136010001

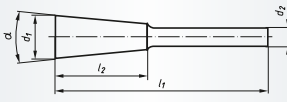
							<p>Packing unit: 5 pc. per type Further dimensions, cuts and shank lengths on request.</p>												
Description	Cut	d ₁ mm	l ₂ mm	d ₂ mm	l ₁ mm	α	Product-Number	recommended for								New burrs			
MFNS 1213.06	Z1	12	13	6	53	17°	A120412136010001							6		8			■
MFNS 1213.06	Z3	12	13	6	53	17°	A120412136030001	1	2										■
MFNS 1230.06	Z3	12	30	6	70	8°	A120412306030001	1	2										■



Industry

Shape W, Cylindrical multiple concave burrs

Ordering example: A12430340

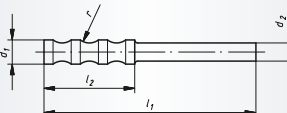
							<p>Packing unit: 10 pc. per type Further dimensions, cuts and shank lengths on request.</p>												
Description	Cut	d ₁ mm	l ₂ mm	d ₂ mm	l ₁ mm	r mm	Product-Number	recommended for								New burrs			
MFW 0620.06	16	6	20	6	60	3	A12430340	1	2					6					■
MFW 0830.06	18	8	30	6	70	5	A12433401	1	2					6					■



Burrs with internal thread

Ordering example: A122022150803

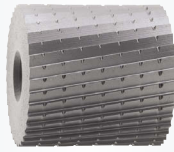

Packing unit:

2 pc. per type

MFAS = with end-cut

Other dimensions and cuts available on request.

Suitable mounting arbors pages 410

Description	Shape	Cut	d ₁ mm	l ₂ mm	B mm	Product-Number	recommended for								New burrs
MFA 2215.08		Z3	22	15	M 8	A122022150803	1	2	3	4		7			■
MFA 3030.10		Z2	30	30	M 10	A122030301002	1				5	6		8	■
MFAS 2215.08		Z3	22	15	M 8	A1220221508030001	1	2	3	4		7			■
MFAS 3030.10		Z2	30	30	M 10	A1220303010020001	1				5	6		8	■
MFD 2018.08		Z3	20	18	M 8	A122520180803	1	2	3	4		7			■
MFD 2522.10		Z1	25	22	M 10	A122525221001						6		8	■
MFD 2522.10		Z2	25	22	M 10	A122525221002	1				5	6		8	■
MFD 3027.12		Z3	30	27	M 12	A122530271203	1	2	3	4		7			■
MFE 2535.12		Z3	25	35	M 12	A122825351203	1	2	3	4		7			■
MFG 3555.12		Z1	35	55	M 12	A122635551201						6		8	■
MFH 2055.10		Z1	20	55/65	M 10	A122720551001						6		8	■
MFH 2055.10		Z2	20	55/65	M 10	A122720551002	1				5	6		8	■



Burrs with internal thread

Ordering example: A122320551001

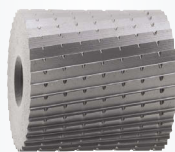

Packing unit:
2 pc. per type
Further dimensions and cuts on request.
Suitable mounting arbors pages 410

Description	Shape	Cut	d ₁ mm	l ₂ mm	B mm	Product-Number	recommended for	New burrs
MFL 2055.10		Z1	20	55	M 10	A122320551001	6 8	■
MFM 2540.10		Z3	25	40	M 10	A122225401003	1 2 3 4 7	■

What is your experience when using this tool?

V3 Control: Fast removal whilst maintaining your workpiece in view – this allows you to grind exactly where you want to (I tested this myself).

Eva Jensch
Sales Department

www.lukas-erzett.com





Industry

Tool-sets, cut 5, shank 3 mm

Ordering example: A1239000110



Packing unit:
1 pc. per type

Description	Shank Ø mm	Cut	Contents	1 piece each	Product-Number	recommended for	
F1	3	Z5	10-pieces	MF 807, MF 813, MF 841, MF 845, MF 850, MF 853, MF 864, MF 866, MF 872, MF 874	A1239000110	① ② ⑥	■



Industry

Tool-sets, cut 5, shank 6 mm

Ordering example: A123900003



Packing unit:
1 pc. per type

Description	Shank Ø mm	Cut	Contents	1 piece each	Product-Number	recommended for	
F3	6	Z3	10-pieces	MFA 0616, MFA 1225, MFC 1225, MFD 0403, MFD 1210, MFE 1220, MFG 1230, MFH 1230, MFK 0620, MFM 0618	A123900003	① ② ⑥	■

Filing Discs and Rings Tailor-made solution

84 Technical Information

85 Filing Discs and Rings Special production



Product line marking

Product lines are labelled in the table header with the appropriate tabs. Further information on page **14** and **15**.

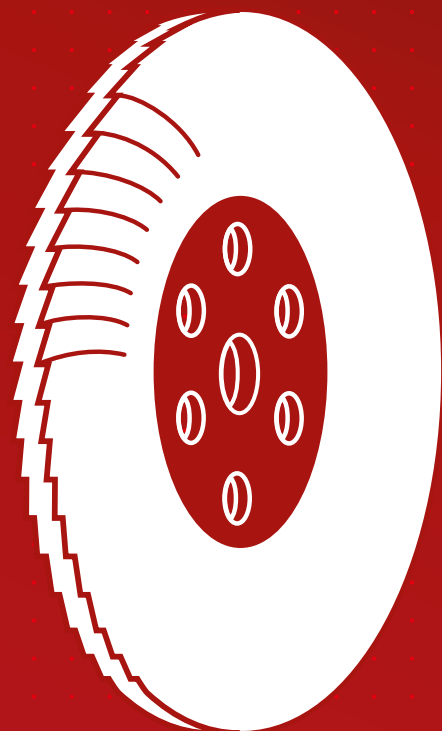

Types of cut and their application

	Z1	Z2	Z3
	Aluminium alloys, plastics v = 38–150 m/min Wood v = 150–300 m/min	Aluminium alloys, plastics v = 38–150 m/min Bronze, brass v = 150–300 m/min	Steel up to 450 N/mm ² v = 38–75 m/min Cast and malleable iron v = 38–150 m/min

Number of teeth

Disc-Ø Ring-Ø	Z1 cut coarse		Z2 cut medium		Z3 cut fine	
	Disc	Ring	Disc	Ring	Disc	Ring
160	120	160	160	200	200	240
210	160	200	200	240	240	280
260	200	240	240	280	280	320
310	240	280	280	320	320	360

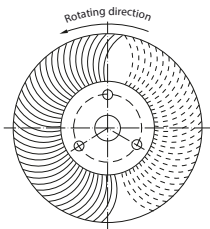

Cut design 1
Right-hand cutting,
usable both sides

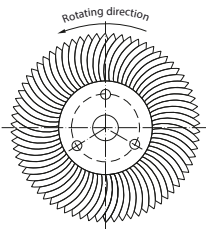

Cut design 4
One-sided cutting with
teeth on periphery

Recommended speeds

Material	speeds approx. RPM
Cast iron	75/150
Steel up to 450 N/mm ²	75
Aluminium alloys	75/150
Bronze, brass	300
Plastics	75/150
Wood	300



Filing discs

Ordering example: F 16-R-1 Z3

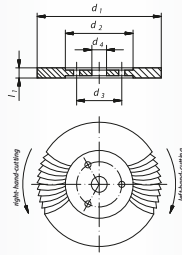
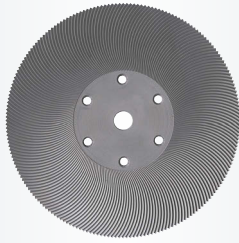

Packing unit:

1 pc. per type

If left-hand-cutting is desired for cut design 1 and cut design 4 please replace R by L in the Lukas-No.

Further dimensions on request.

Description	Cut	d ₁ mm	d ₂ mm	d ₃ mm	d ₄ mm	l ₁ mm	Number of bores	recommended for					
F 16-R-1	Z1	160	80	60	15	7	3	①		⑤	⑥	⑧	▲
F 16-R-1	Z2	160	80	60	15	7	3	①		⑤	⑥	⑧	▲
F 16-R-1	Z3	160	80	60	15	7	3	①		⑤	⑥	⑧	▲
F 16-R-4	Z1	160	80	60	15	7	3	①		⑤	⑥	⑧	▲
F 16-R-4	Z2	160	80	60	15	7	3	①		⑤	⑥	⑧	▲
F 16-R-4	Z3	160	80	60	15	7	3	①		⑤	⑥	⑧	▲
F 21-R-1	Z1	210	80	60	15	8	3	①		⑤	⑥	⑧	▲
F 21-R-1	Z2	210	80	60	15	8	3	①		⑤	⑥	⑧	▲
F 21-R-1	Z3	210	80	60	15	8	3	①		⑤	⑥	⑧	▲
F 21-R-4	Z1	210	80	60	15	8	3	①		⑤	⑥	⑧	▲
F 21-R-4	Z2	210	80	60	15	8	3	①		⑤	⑥	⑧	▲
F 21-R-4	Z3	210	80	60	15	8	3	①		⑤	⑥	⑧	▲
F 26-R-1	Z1	260	110	90	20	9	6	①		⑤	⑥	⑧	▲
F 26-R-1	Z2	260	110	90	20	9	6	①		⑤	⑥	⑧	▲
F 26-R-1	Z3	260	110	90	20	9	6	①		⑤	⑥	⑧	▲
F 26-R-4	Z1	260	110	90	20	9	6	①		⑤	⑥	⑧	▲
F 26-R-4	Z2	260	110	90	20	9	6	①		⑤	⑥	⑧	▲
F 26-R-4	Z3	260	110	90	20	9	6	①		⑤	⑥	⑧	▲
F 31-R-1	Z1	310	125	90	20	10	6	①		⑤	⑥	⑧	▲
F 31-R-1	Z2	310	125	90	20	10	6	①		⑤	⑥	⑧	▲
F 31-R-1	Z3	310	125	90	20	10	6	①		⑤	⑥	⑧	▲
F 31-R-4	Z1	310	125	90	20	10	6	①		⑤	⑥	⑧	▲
F 31-R-4	Z2	310	125	90	20	10	6	①		⑤	⑥	⑧	▲
F 31-R-4	Z3	310	125	90	20	10	6	①		⑤	⑥	⑧	▲

Made of alloyed tool steel (WS) for all machinable materials with tensile strength up to approx. 450 N/mm². Particularly suitable for the machining of aluminium and non-ferrous metals. Filing discs in cut design 1 can be used on

both sides. For the severest conditions, filing discs in HSS are also available on request.



Filing rings

Ordering example: FR 16 Z3

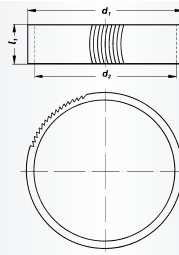

Packing unit:
1 pc. per type
Further dimensions on request.

Description	Cut	d1 mm	l1 mm	d2 mm	recommended for									
FR 16	Z1	160	40	145	①				⑤	⑥		⑧		▲
FR 16	Z2	160	40	145	①				⑤	⑥		⑧		▲
FR 16	Z3	160	40	145	①				⑤	⑥		⑧		▲
FR 21	Z1	210	40	195	①				⑤	⑥		⑧		▲
FR 21	Z2	210	40	195	①				⑤	⑥		⑧		▲
FR 21	Z3	210	40	195	①				⑤	⑥		⑧		▲
FR 26	Z1	260	40	245	①				⑤	⑥		⑧		▲
FR 26	Z2	260	40	245	①				⑤	⑥		⑧		▲
FR 26	Z3	260	40	245	①				⑤	⑥		⑧		▲
FR 31	Z1	310	40	295	①				⑤	⑥		⑧		▲
FR 31	Z2	310	40	295	①				⑤	⑥		⑧		▲
FR 31	Z3	310	40	295	①				⑤	⑥		⑧		▲

Filing rings of WS are seamless forged. If correctly used, they will not crack even under the most severe conditions. **Application – similar to filing discs.**

Not available in high speed steel.

Engraving cutters of solid carbide and HSS

- 88 General Information

- 89 Technical Information

- 90 Engraving cutters of solid carbide and HSS





Product line marking

Product lines are labelled in the table header with the appropriate tabs. Further information on page **14** and **15**.

Engraving cutters are available in the following tungsten carbide grade:

Engraving cutters of High Speed Steel (HSS) are available in the following special HSS-qualities

<p>K 10 F Micro grain carbide for machining all materials, for machining steel, cast steel, non-ferrous metals and plastics. Extra long life!</p>	<p>HSS-50 for machining high-tensile and high-grade carbide materials and heat resistant qualities.</p> <p>HSS-60 applications similar to HSS-50, but with extended life. Performance is improved when used in conjunction with a high quality cutting oil.</p> <p>We supply our engraving cutters semi-finished with rough-ground profile (+0,1 mm) or finish ground to your specification.</p>
--	--

Example	Description	Page
	Engraving cutters of solid carbide	90
	Tungsten carbide cutters, spiral flute type	90
	HSS engraving cutters	91

Engraving Cutters – Recommendation for various applications

For optimal results the cutting and lead angles have to suit the material to be machined.
The values in the tables are recommendations.

Recommended cutting and lead angles

Material to be machined	Engraving cutters of Tungsten Carbide			Engraving cutters of HSS		
	$\sphericalangle \alpha$	$\sphericalangle \beta$	$\sphericalangle \gamma$	$\sphericalangle \alpha$	$\sphericalangle \beta$	$\sphericalangle \gamma$
Cast iron, cast steel	25°	15°	5°	25°	15°	5°
Brass, aluminium	30°	15°	5°	30°	15°	5°
Plastics, reinforced and non-reinforced	35°	15°	5°	35°	15°	5°
Light metals, copper, gold, silver	30°	15°	5°	30°	15°	5°

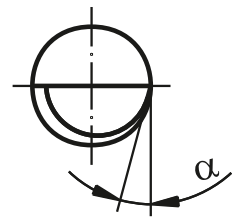
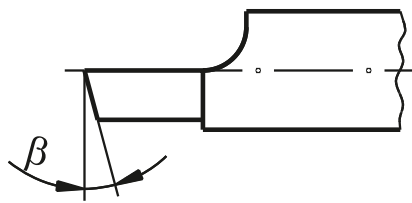
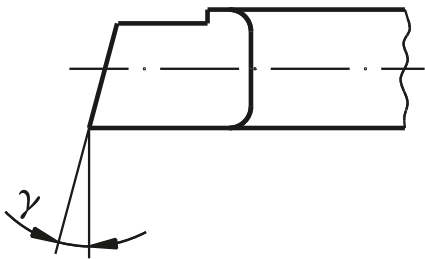

Recommended cutting speeds in m/min

Material to be machined	Engraving cutters of Tungsten Carbide	Engraving cutters of HSS	Engraving cutters of HSS
	K 10 F	HSS-50	HSS-60
Cast iron, cast steel	60–100	50–70	50–70
Steel up to 900 N/mm ²	120–160	40–70	40–70
Steel above 900 N/mm ²	50–70	–	25–40
Brass, aluminium	200–400	200–250	200–250
Plastics, reinforced and non-reinforced	200–600	200–300	200–300

Recommended feed rates f_z in mm

Material to be machined	
Cast iron, cast steel	0,04–0,1
Steel up to 900 N/mm ²	0,05–0,08
Steel above 900 N/mm ²	0,04–0,08
Brass, aluminium	0,08–0,15
Plastics, reinforced and non-reinforced	0,05–0,20



Engraving cutters of solid carbide

Ordering example: A1300403042

A



B
100°



C



D
60°



F



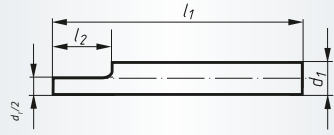

Packing unit:
1 pc. per type

Further profiles and dimensions on request
d₁/2 as per your request
l₂ does not apply to profile F
Tolerance of semi-finished cutting edge + 0,1,
finish ground on request

Description	Profile	Quality	d ₁ mm	l ₁ mm	l ₂ mm	Product-Number	recommended for					
HGA 03.040	D	K10F	3	40	6	A1300403042	1		5	6	8	■
HGA 04.040	A	K10F	4	40	6	A1300404012	1		5	6	8	■
HGA 04.040	D	K10F	4	40	6	A1300404042	1		5	6	8	■
HGA 04.040	F	K10F	4	40	6	A1300404062	1		5	6	8	■
HGA 04.060	A	K10F	4	60	6	A1300405012	1		5	6	8	■
HGA 04.060	D	K10F	4	60	6	A1300405042	1		5	6	8	■
HGA 06.070	A	K10F	6	70	8	A1300407012	1		5	6	8	■
HGA 06.070	D	K10F	6	70	8	A1300407042	1		5	6	8	■
HGA 06.100	D	K10F	6	100	8	A1300407142	1		5	6	8	■
HGA 08.080	A	K10F	8	80	12	A1300408012	1		5	6	8	■
HGA 08.100	A	K10F	8	100	12	A1300408112	1		5	6	8	■
HGA 10.080	A	K10F	10	80	14	A1300409012	1		5	6	8	■
HGA 10.100	A	K10F	10	100	14	A1300409112	1		5	6	8	■
HGA 12.080	A	K10F	12	80	16	A1300410012	1		5	6	8	■
HGA 12.100	A	K10F	12	100	16	A1300410112	1		5	6	8	■



Engraving cutters of solid carbide, spiral fluted

Ordering example: A1300484071



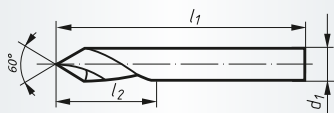

Packing unit:
1 pc. per type

Further dimensions on request.
Relief-grinding 25°
Quality K 10 F = micro grain tungsten carbide

Description	d ₁ mm	l ₁ mm	l ₂ mm	Product-Number	recommended for				
HGS 03.040	3	40	15	A1300484071			6	8	■
HGS 04.040	4	40	20	A1300485071			6	8	■
HGS 06.050	6	50	22	A1300486071			6	8	■

Application:

Engraving of non-ferrous metals and plastics with minimum generation of burr.



Industry

Engraving cutters of HSS-50

Ordering example: A135046106

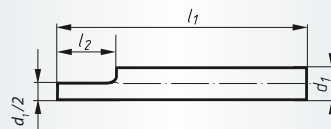
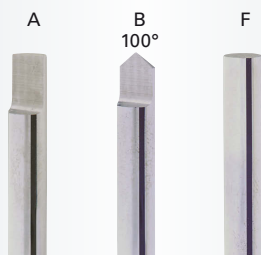

Packing unit:

5 pc. per type

Further profiles and dimensions on request

$d_1/2$ as per your request

l_2 does not apply to profile F

Tolerance of semi-finished cutting edge + 0,1, finish ground on request

Description	Profile	Quality	d_1 mm	l_1 mm	l_2 mm	Product-Number	recommended for		
SGA 04.060	F	HSS-50	4	60	10	A135046106	①	⑤ ⑥ ⑧	■
SGA 06.080	A	HSS-50	6	80	14	A135046201	①	⑤ ⑥ ⑧	■
SGA 06.080	F	HSS-50	6	80	14	A135046206	①	⑤ ⑥ ⑧	■
SGA 06.160	F	HSS-50	6	160	14	A135046256	①	⑤ ⑥ ⑧	■
SGA 08.125	F	HSS-50	8	125	16	A135046406	①	⑤ ⑥ ⑧	■



Industry

Engraving cutters of HSS-60

Ordering example: A136046101

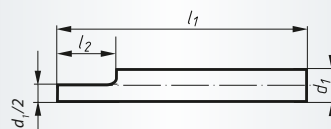
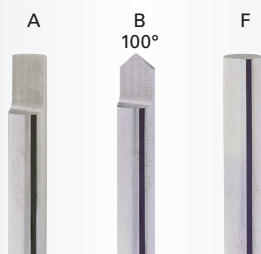

Packing unit:

5 pc. per type

Further profiles and dimensions on request

$d_1/2$ as per your request

l_2 does not apply to profile F

Tolerance of semi-finished cutting edge + 0,1, finish ground on request

Description	Profile	Quality	d_1 mm	l_1 mm	l_2 mm	Product-Number	recommended for		
SGA 04.060	A	HSS-60	4	60	10	A136046101	①	⑤ ⑥ ⑧	■
SGA 06.080	A	HSS-60	6	80	14	A136046201	①	⑤ ⑥ ⑧	■
SGA 06.080	F	HSS-60	6	80	14	A136046206	①	⑤ ⑥ ⑧	■



“We invest continually in our company's future, with solid and independent funding from our own resources.”

Stefan Lukas

Mounted points

94	Technical Information
96	Qualities and areas of application
97	Choice of the optimal grinding tool
98	Safety instructions
99	A summary of available shapes
106	Mounted points
130	Mounted points, tailor-made solution



Product line marking

Product lines are labelled in the table header with the appropriate tabs. Further information on page **14** and **15**.

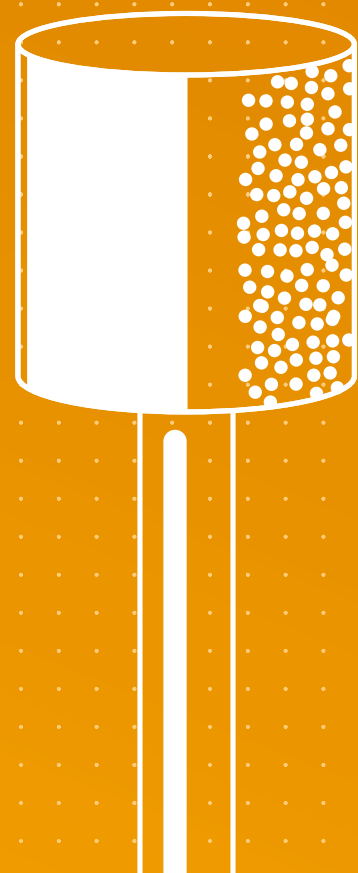

Technical Information

Grit sizes, ISO 525

Coarse	4, 5, 6, 7, 8, 10, 12, 14, 16, 20, 24
Medium	30, 36, 46, 54, 60
Fine	70, 80, 90, 100, 120, 150, 180, 220
Very fine	230, 240, 280, 320, 360, 400, 500

Hardness grade, ISO 525

The hardness is a measure of the strength with which the grits are retained by the bond. It is determined by special measuring instruments. The grades are indicated by letter. The hardness increases in alphabetical order.

extreme soft	very soft	soft	medium	hard	very hard	extreme hard
A	E	H	L	P	T	X
B	F	I	M	Q	U	Y
C	G	Jot	N	R	V	Z
D		K	O	S	W	

Structure

The structure of grinding wheels is determined by the ratio of pore volume to the volume of grit and bond. The international standardized structure numbers start with 0 and end with 14.

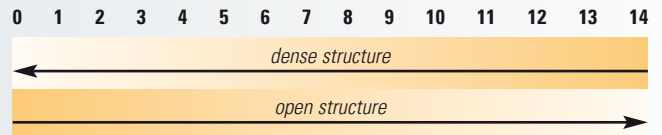

Bond

The bond retains the grit in the grinding wheel. The most important bonds are ISO 525:

Vitrified bond

V = vitrified bond

The figure behind the bonding code is a company-internal reference.

Organic bonds

Ba = resin bond

BF = resin bond, reinforced

R = rubber bond or other elastomers

RF = rubber bond, reinforced

Impregnation

The impregnation of vitrified bonds considerably improves the performance of the mounted points when grinding certain steels.

Su = with sulphur

Lu = with resin

W = with wax

F = with grinding oil

Description of Mounted points

Shape	Diameter	Length	Shank	Abrasive	Grit size	Hardness	Bond
ZY	1632	06	EKR		46	N	V4

Technical Information

Quality

The wide range of abrasive applications, from snagging to polishing, demands mounted points that meet the requirements of stock removal, surface finish and tool life. The crucial formulation of the mounted point quality results from a combination of the technical

application and selection of the most suitable raw materials. The following tables state the type of raw materials used in LUKAS mounted points.

Abrasives

<p>NK</p>  <p>Aluminum oxide</p>	<p>EKR</p>  <p>Aluminum oxide pink</p>	<p>EKW</p>  <p>Aluminum oxide white</p>	<p>EKD</p>  <p>Aluminum oxide dark red</p>
<p>EKbr</p>  <p>Standard aluminum oxide pink, type brown</p>	<p>MK</p>  <p>Mixture EKR/NK</p>	<p>HK</p>  <p>Mixture EKW/NK</p>	<p>HKD</p>  <p>Mixture EKW/EKD</p>
<p>MKD</p>  <p>Mixture NK/EKD</p>	<p>RKD</p>  <p>Mixture EKD/EKR</p>	<p>SiC-ALU</p>  <p>Silicon carbide green</p>	<p>SiCdkl</p>  <p>Silicon carbide dark</p>
<p>NDW</p>  <p>Mixture NK/EKD/EKK white</p>	<p>CERAMIC</p>  <p>Mixture of ceramic grain and monocystal aluminium oxide</p>	<p>HOK</p>  <p>Mixture spherical aluminium oxide grain</p>	

Qualities and areas of application

From the large variety of specifications we have selected various dimensions and shapes in well-proven standard qualities for you. These mounted points are available ex-stock.

			Materials								
best suitable suitable	Reference/ Qualities	Cutting speed vc [m/s]	1	2	3	4	5	6	7	8	9
			steels and cast steels	alloyed, tempered steels	tool steels	rust, acid and heat resistant steels and cast steels	cast iron	aluminium, magnesium and copper alloys	titanium and nickel alloys	plastics, wood, rubber	glass, carbides
	EKR aluminium oxide pink	ca. 30 - 50									
	EKWbr aluminium oxide white, type brown	ca. 25 - 40									
	RKD mixture aluminium oxide deep red / aluminium oxide pink	ca. 30 - 50									
	NK-BA-soft aluminium oxide resin bonded iron and sulphur free	ca. 40 - 50									
	NK-BA-hard aluminium oxide resin bonded	ca. 40 - 50									
	HK mixture aluminium oxide white / aluminium oxide	ca. 40 - 50									
	MK mixture aluminium oxide pink / aluminium oxide	ca. 30 - 50									
	NDW mixture aluminium oxide, aluminium oxide dark red and mono cristall aluminium oxide white	ca. 10 - 30									
	CERAMIC Mixture of ceramic grain and monocrystal aluminium oxide	ca. 30 - 50									
	EKW aluminium oxide white	ca. 20 - 35									
	EKbr aluminium oxide pink, type brown	ca. 40 - 50									
	SiC-ALU silicon carbide green	ca. 25 - 40									
	HOK mixture spherical aluminium oxide grain	ca. 5 - 20									

These quality recommendations apply only when optimum application conditions are used.

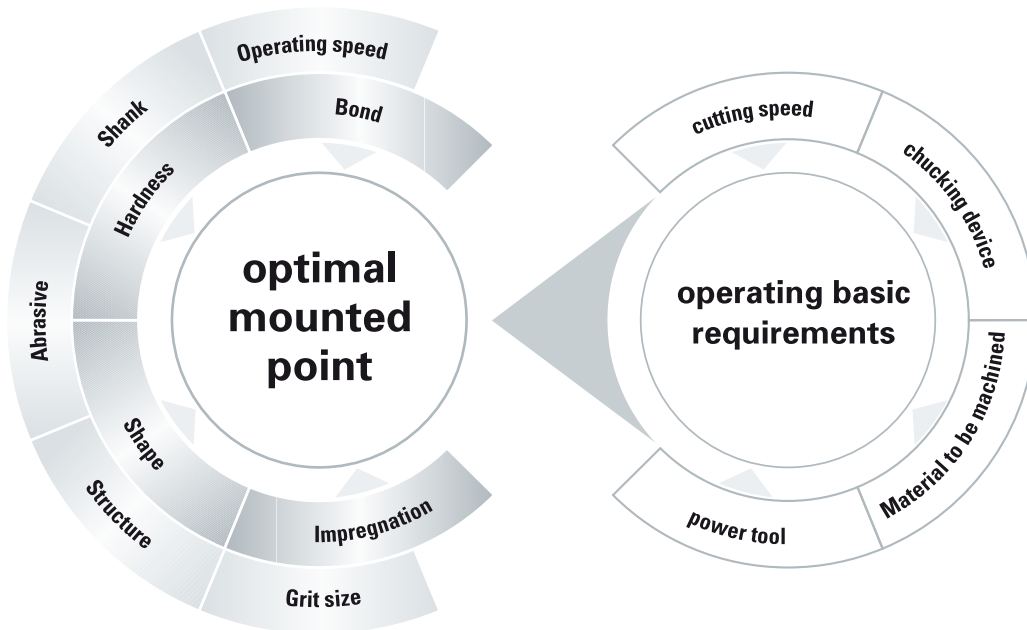

Choice of the optimal grinding tool



Speeds for grinding tools

		Recommended cutting speed v_c [m/s]							
		5	10	20	30	40	50	63	80
		Rotational speed [min ⁻¹]							
Tool-diameter [mm]	2	47.700	95.500	191.000	286.500	382.000	477.500	601.600	763.900
	3	31.800	63.700	127.300	191.000	254.600	318.300	401.100	509.300
	4	23.900	47.700	95.500	143.200	191.000	238.700	300.800	382.000
	5	19.100	38.200	76.400	114.600	152.800	191.000	240.600	305.600
	6	15.900	31.800	63.700	95.500	127.300	159.200	200.500	254.600
	8	11.900	23.900	47.700	71.600	95.500	119.400	150.400	191.000
	10	9.500	19.100	38.200	57.300	76.400	95.500	120.300	152.800
	13	7.300	14.700	29.400	44.100	58.800	73.500	92.600	117.500
	20	4.800	9.500	19.100	28.600	38.200	47.700	60.200	76.400
	25	3.800	7.600	15.300	22.900	30.600	38.200	48.100	61.100
	32	3.000	6.000	11.900	17.900	23.900	29.800	37.600	47.700
	40	2.400	4.800	9.500	14.300	19.100	23.900	30.100	38.200
	50	1.900	3.800	7.600	11.500	15.300	19.100	24.100	30.600
	60	1.600	3.200	6.400	9.500	12.700	15.900	20.100	25.500
	80	1.200	2.400	4.800	7.200	9.500	11.900	15.000	19.100
	100	1.000	1.900	3.800	5.700	7.600	9.500	12.000	15.300

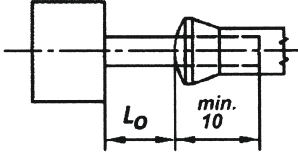
Safety instructions

Schleifkörper keramisch Brousicí tělíska keramická Mounted points - vitrified Muelas cerámicas Meule vitrifiée										
A200002032602 ZY 2032.06 EKR 36 N V4										
Stück pcs.	20	FA1334200								
 4 027497 013296			 EN 12413							
						<table border="1"> <thead> <tr> <th>L_o(mm)</th> <th>max. rpm</th> </tr> </thead> <tbody> <tr> <td>10</td> <td>40.600</td> </tr> <tr> <td>15</td> <td>34.500</td> </tr> <tr> <td>20</td> <td>29.700</td> </tr> </tbody> </table>			L _o (mm)	max. rpm
L _o (mm)	max. rpm									
10	40.600									
15	34.500									
20	29.700									

Peripheral speeds, safety

Our mounted points are manufactured with state of the art technology for high peripheral speed and the safety is well in accordance with the EN 12413.

We produce mounted points, vitrified and resin bonded, for a maximum peripheral operating speeds of 50 m/s.

These maximum operating speeds are limited by the following criteria:

1. The mass (weight) of the mounted point
2. The shape of the mounted point
3. The shank diameter
4. The overhang of the shank
5. The shank material
6. The run-out of the mounted point









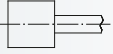

The safety aspect of a grinding wheel is of paramount importance.

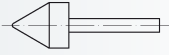
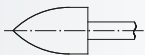
When using and storing Mounted Points, note must be taken without fail of the safety-regulations and regulations for prevention of accidents, including the FEPA-safety recommendations.

We enclose a safety ticket with all our deliveries, as illustrated above. The maximum speeds shown on these safety tickets refer to the overhang length (open shank length L_0) of the shank i.e. 10, 15 and 20 mm respectively.

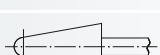
No raw materials used in our grinding wheels are a hazard to health and safety.

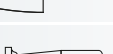
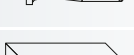
A summary of available shapes

Shape	Type	Shape (Lukas)	Page
	Cylindrical, Typ 1	ZY	106
	Cylindrical, Typ 2	ZY2	112
	Cylindrical pointed nose	WKS	113
	Arch pointed nose	SP	113
	Spherical	KU	115
	Cylindrical round nose	WR	115
	Cup	TO	117
	Conical round nose	KE	117
	American shapes	A	118
	American shapes	B	120
	Miniature-Mounted points	D	120
	Handstones	–	124
	Mounted points, assortments	–	125
	Power Tools	–	381

Qualities:

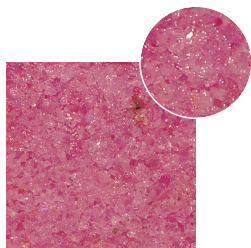

EKR
aluminium oxide pink



EKWbr
aluminium oxide white,
type brown



General Information

<p>Properties of workpiece material:</p>	<p>Mounted points in various qualities are needed to cover the wide spectrum of the numerous steel types and their resulting workpieces.</p>	
<p>Industries:</p>	<ul style="list-style-type: none"> • Machine tools • Automotive • Equipment manufacturers 	<ul style="list-style-type: none"> • Vessel manufacturers • Shipyards • and much more
<p>Examples of application:</p>	<ul style="list-style-type: none"> • General rough grinding • Fettling • Rough grinding of weld seams 	<ul style="list-style-type: none"> • Finish grinding of weld seams • Deburring
<p>LUKAS-grinding tools:</p>	<p>The wide selection of LUKAS grinding tools incorporates numerous shapes, sizes and qualities. You will find the correct tool from our standard range to solve most grinding problems irrespective of material to be ground, type of machine or any other influencing factors. These mounted points are designed for high stock removal and long tool life.</p>	



Qualities:



RKD

mixture aluminium oxide
deep red / aluminium
oxide pink

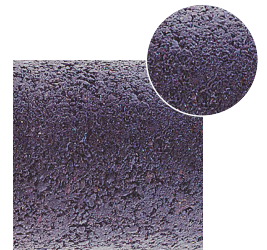

NK-BA-soft

aluminium oxide resin
bonded iron and
sulphur free

General Information

<p>Properties of workpiece material:</p>	<p>Alloyed steels i.e., non-rusting steels are included in the materials which are difficult to machine. They tend to “smear” due to the nickel content, and as a result of poor heat dissipation causes overheating of the material within the grinding contact zone.</p>	
<p>Industries:</p>	<ul style="list-style-type: none"> • Steel construction and fabrication (facades, railings, sanitary equipment) • Vessel manufacturing • Casings and panelling 	<ul style="list-style-type: none"> • Medical technology • Shipyards • Food industry • and much more
<p>Examples of application:</p>	<ul style="list-style-type: none"> • Rough and finish grinding • Deburring • Fettling 	<ul style="list-style-type: none"> • Removing weld seams • Surface finishing
<p>LUKAS-grinding tools:</p>	<p>LUKAS has developed particular high performance qualities for alloyed steels distinguished by exceptional stock removal despite operating under difficult conditions. These tools contain no iron, no sulphur and no halogens; a chemical reaction (corrosion) of the workpiece material in the grinding contact zone is generally therefore avoided.</p>	

Qualities:

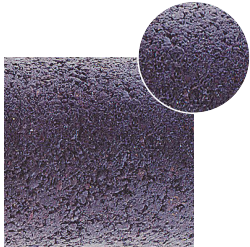

NK Ba-hard

aluminium oxide
resin bonded

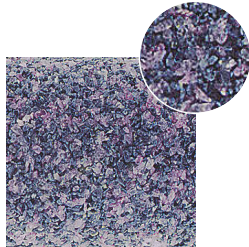

MK

mixture aluminium oxide
pink / aluminium oxide

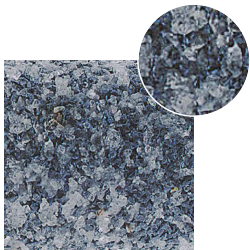

HK

mixture aluminium oxide
white / aluminium oxide



General Information

<p>Properties of workpiece material:</p>	<p>The characteristics of the various types of cast materials are normally determined by their carbon content, and the way in which the carbon is removed from the material structure.</p> <p>Cast components are generally “rough” machined. The skin contains inclusions of sand from the casting process; large burrs, runners and risers, holes and cracks must all be removed by grinding. These areas to be ground are often somewhat inaccessible.</p>
<p>Industries:</p>	<ul style="list-style-type: none"> • Manufacturers of cast components i.e. engine blocks, gear box casings, cylinder heads, frames, stands, machine slides, gears, crankshafts, pump and turbine housings, machine tool components • and much more
<p>Examples of application:</p>	<ul style="list-style-type: none"> • Deburring • Fettling • Removing holes and cracks • Finish grinding of repair welds • Polishing
<p>LUKAS-grinding tools:</p>	<p>The LUKAS mounted points specifically formulated to grind cast materials contain special grain combinations and tough bonding systems; such qualities give optimum performance for the applications mentioned above.</p> <p>The aggressiveness of the abrasive grain and the smooth running of the mounted points allow for an ergonomic method of machining requiring minimum force. Mounted points with specially extended shafts are also available on request.</p>



Qualities:

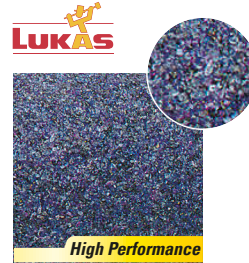

NDW
mixture aluminium oxide, aluminium oxide dark red and mono crystal aluminium oxide white

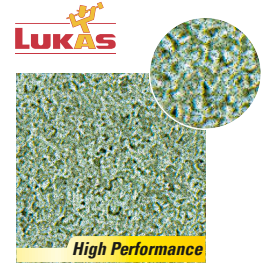

CERAMIC
Mixture of ceramic grain and monocrystal aluminium oxide

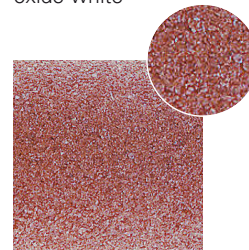

EKbr
aluminium oxide pink, type brown



EKW
aluminium oxide white

General Information

Properties of workpiece material:	Precision is a major factor in the tool and mould industry. Tool steels are selected with the appropriate hardness and toughness to suit the application; special mounted point qualities are therefore essential to achieve the tight tolerances required.
Industries:	<ul style="list-style-type: none"> • Toolmakers • Pattern shops • Mould manufacturers • Aerospace
Examples of application:	<ul style="list-style-type: none"> • Re-grinding • Groove grinding • Fine deburring • Finish grinding • Lapping • Coordinate grinding • Ball bearing grinding • Turbine blades
LUKAS-grinding tools:	LUKAS mounted points for tool and mould & die are extremely dimensionally stable and can cut even the hardest materials. Ceramic abrasive grit is extremely friable due to its microcrystal structure. This makes it self-sharpening. Therefore materials which are difficult to cut (e.g. nickel-based alloys) can be machined without any problems. Moreover, the use of special grain qualities ensures a long service life. Our broad and varied range enables you to work in even the narrowest of spaces.

Quality:

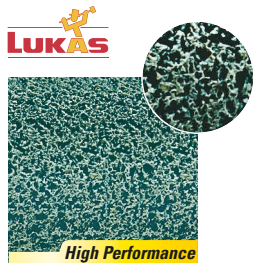

SIC-ALU

silicon carbide green



General Information

<p>Properties of workpiece material:</p>	<p>Aluminium and its associated alloys have many varied and positive characteristics making it the second most widely used metal after steel.</p> <p>Aluminium has only 1/3 the density of steel. The purer the metal, the weaker it becomes but allows for better shape forming. Unsuitable mounted point qualities are often used which “load”.</p>	
<p>Industries:</p>	<ul style="list-style-type: none"> • Transport (railways, ships, automotive, aerospace) • Metal construction (bridges, cranes, silos) 	<ul style="list-style-type: none"> • Chemical industry (vessels, pumps, pipes) • Equipment manufacturing • Engine, transmission parts • and much more
<p>Examples of application:</p>	<ul style="list-style-type: none"> • Deburring • Fettingling 	<ul style="list-style-type: none"> • Re-working • Surface finishing
<p>LUKAS-grinding tools:</p>	<p>The LUKAS mounted points in the quality SIC – ALU have been developed solely for this application. Due to a special structure, maximum tool life is achieved whilst preventing “loading” of material within the pores. The self-dressing effect is aided by the use of a special impregnation.</p>	



Quality:



HOK

mixture spherical aluminium oxide grain

General Information

<p>Properties of workpiece material:</p>	<p>Materials such as rubber or plastic are very elastic and have a very low melting point. They flex and generate heat; this often results in a bad odour and loading.</p>	
<p>Industries:</p>	<ul style="list-style-type: none"> • Machining rubber • Machining plastic 	
<p>Examples of application:</p>	<ul style="list-style-type: none"> • Tyre repair and re-vulcanizing • Repair of conveyor belts 	<ul style="list-style-type: none"> • Preparation of various areas for adhesion • Deburring of rubber or plastic components
<p>LUKAS-grinding tools:</p>	<p>LUKAS abrasive tools for the machining of rubber and plastic contain a special hollow grain (HOK) in a very open ceramic structure. This abrasive media creates permanent small razor-sharp cutting edges which pluck-out the material from the surface. Consequently, these tools are ideally suited for the machining applications as illustrated.</p>	



Shape ZY, Cylinder, Type 1 (according to DIN 69170)

Ordering example: A200000408377

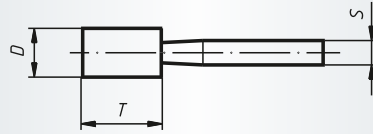

Packing unit:

20 pcs. per type

Further dimensions, qualities and shank lengths on request.

Description	Quality	D mm	T mm	S mm	Product-Number	recommended for													
ZY 0408.03	CERAMIC 80 L V118	4	8	3 x 30	A200000408377	②	③	④					⑦						■
ZY 0510.03	CERAMIC 80 L V118	5	10	3 x 30	A200000510377	②	③	④					⑦						■
ZY 0613.03	CERAMIC 80 L V118	6	13	3 x 30	A200000613377	②	③	④					⑦						■
ZY 1020.06	CERAMIC 80 L V118	10	20	6 x 40	A200001020677	②	③	④					⑦						■
ZY 1325.06	CERAMIC 46 L V118	13	25	6 x 40	A200001325677	②	③	④					⑦						■
ZY 1632.06	CERAMIC 46 L V118	16	32	6 x 40	A200001632677	②	③	④					⑦						■
ZY 2032.06	CERAMIC 46 L V118	20	32	6 x 40	A200002032677	②	③	④					⑦						■



Shape ZY, Cylinder, Type 1 (according to DIN 69170)

Ordering example: A200000306353

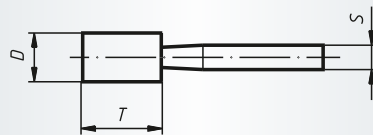

Packing unit:

20 pcs. per type

Further dimensions, qualities and shank lengths on request.

Description	Quality	D mm	T mm	S mm	Product-Number	recommended for													
ZY 0306.03	NDW 100 QU V115	3	6	3 x 50	A200000306353	②	③												■
ZY 0306.03	NDW 100 QU V115	3	6	3 x 30	A2000003063530001	②	③												■
ZY 0408.03	NDW 100 QU V115	4	8	3 x 50	A200000408353	②	③												■
ZY 0408.03	NDW 100 QU V115	4	8	3 x 30	A2000004083530001	②	③												■
ZY 0610.03	NDW 100 QU V115	6	10	3 x 50	A200000610353	②	③												■
ZY 0610.03	NDW 100 QU V115	6	10	3 x 30	A2000006103530001	②	③												■
ZY 0810.03	NDW 100 QU V115	8	10	3 x 50	A200000810353	②	③												■
ZY 0810.03	NDW 100 QU V115	8	10	3 x 30	A2000008103530001	②	③												■
ZY 1013.03	NDW 100 QU V115	10	13	3 x 50	A200001013353	②	③												■
ZY 1013.03	NDW 100 QU V115	10	13	3 x 30	A2000010133530001	②	③												■



Shape ZY, Cylinder, Type 1 (according to DIN 69170)

Ordering example: A200000306602

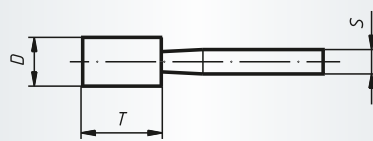

Packing unit:

20 pcs. per type

Further dimensions, qualities and shank lengths on request.

Description	Quality	D mm	T mm	S mm	Product-Number	recommended for														
ZY 0306.06	EKR 100 N V4	3	6	6 x 40	A200000306602	1	2	3												
ZY 0306.06	RKD 120 QU V21	3	6	6 x 40	A200000306647		2	3	4											
ZY 0408.03	EKR 80 N V4	4	8	3 x 30	A200000408302	1	2	3												
ZY 0408.03	EKR 100 QU V4	4	8	3 x 30	A2000004083020001	1	2	3												
ZY 0408.03	EKWBR 80 O/P V7	4	8	3 x 30	A200000408312	1	2													
ZY 0408.03	RKD 100 QU V21	4	8	3 x 30	A200000408347		2	3	4											
ZY 0408.06	EKR 80 N V4	4	8	6 x 40	A200000408602	1	2	3												
ZY 0408.06	RKD 100 QU V21	4	8	6 x 40	A200000408647		2	3	4											
ZY 0510.03	EKR 80 N V4	5	10	3 x 30	A200000510302	1	2	3												
ZY 0510.03	EKR 80/100 QU V4	5	10	3 x 30	A2000005103020001	1	2	3												
ZY 0510.03	EKWBR 80 O/P V7	5	10	3 x 30	A200000510312	1	2													
ZY 0510.03	RKD 100 QU V21	5	10	3 x 30	A200000510347		2	3	4											
ZY 0510.06	EKR 80 N V4	5	10	6 x 40	A200000510602	1	2	3												
ZY 0510.06	RKD 100 QU V21	5	10	6 x 40	A200000510647		2	3	4											
ZY 0610.03	EKR 60 N V4	6	10	3 x 30	A200000610302	1	2	3												
ZY 0610.03	EKWBR 60 O/P V7	6	10	3 x 30	A200000610312	1	2													
ZY 0610.03	RKD 80 QU V21	6	10	3 x 30	A200000610347		2	3	4											
ZY 0610.06	EKR 60 N V4	6	10	6 x 40	A200000610602	1	2	3												
ZY 0610.06	RKD 80 QU V21	6	10	6 x 40	A200000610647		2	3	4											
ZY 0610.06	EKW 80 L V1	6	10	6 x 40	A200000610608			3						7		9				
ZY 0810.03	EKR 60 N V4	8	10	3 x 30	A200000810302	1	2	3												
ZY 0810.03	EKR 60/80 QU V4	8	10	3 x 30	A2000008103020001	1	2	3												
ZY 0810.03	EKWBR 60 O/P V7	8	10	3 x 30	A200000810312	1	2													
ZY 0810.03	RKD 80 QU V21	8	10	3 x 30	A200000810347		2	3	4											
ZY 0810.06	EKR 60 N V4	8	10	6 x 40	A200000810602	1	2	3												
ZY 0810.06	RKD 80 QU V21	8	10	6 x 40	A200000810647		2	3	4											
ZY 0810.06	EKW 80 L V1	8	10	6 x 40	A200000810608			3						7		9				
ZY 0816.03	EKR 60 N V4	8	16	3 x 30	A200000816302	1	2	3												
ZY 0816.03	EKWBR 60 O/P V7	8	16	3 x 30	A200000816312	1	2													
ZY 0816.03	RKD 80 QU V21	8	16	3 x 30	A200000816347		2	3	4											
ZY 0816.06	EKR 60 N V4	8	16	6 x 40	A200000816602	1	2	3												
ZY 0816.06	RKD 80 QU V21	8	16	6 x 40	A200000816647		2	3	4											
ZY 0820.06	EKR 60 N V4	8	20	6 x 40	A200000820602	1	2	3												
ZY 1010.03	EKR 60 N V4	10	10	3 x 30	A200001010302	1	2	3												
ZY 1010.03	EKR 60/80 QU V4	10	10	3 x 30	A2000010103020001	1	2	3												
ZY 1010.03	EKWBR. 60 O/P V7	10	10	3 x 30	A200001010312	1	2													
ZY 1010.03	RKD 80 P V21	10	10	3 x 30	A200001010347		2	3	4											
ZY 1010.06	EKR 60 N V4	10	10	6 x 40	A200001010602	1	2	3												
ZY 1010.06	RKD 80 P V21	10	10	6 x 40	A200001010647		2	3	4											
ZY 1010.06	EKW 60 L V1	10	10	6 x 40	A200001010608			3						7		9				
ZY 1013.03	EKR 60 N V4	10	13	3 x 30	A200001013302	1	2	3												
ZY 1013.03	EKWBR 60 O/P V7	10	13	3 x 30	A200001013312	1	2													



Shape ZY, Cylinder, Type 1 (according to DIN 69170)

Ordering example: A200001013602

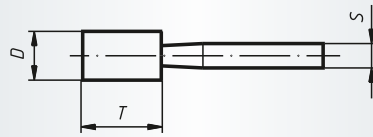

Packing unit:
20 pcs. per type
Further dimensions, qualities and
shank lengths on request.

Description	Quality	D mm	T mm	S mm	Product-Number	recommended for									
ZY 1013.06	EKR 60 N V4	10	13	6 x 40	A200001013602	1	2	3							
ZY 1020.06	EKR 60 N V4	10	20	6 x 40	A200001020602	1	2	3							
ZY 1020.06	EKR 46 QU V4	10	20	6 x 40	A2000010206020001	1	2	3							
ZY 1020.06	EKWBR 60 O/P V7	10	20	6 x 40	A200001020612	1	2								
ZY 1020.06	NK 46 QU BA hard	10	20	6 x 40	A200001020627		2	3		5					
ZY 1020.06	MK 46 N V10	10	20	6 x 40	A200001020616		2		4	5					
ZY 1032.06	EKR 60 N V4	10	32	6 x 40	A200001032602	1	2	3							
ZY 1032.06	EKR 46 QU V4	10	32	6 x 40	A2000010326020001	1	2	3							
ZY 1032.06	EKWBR 60 O/P V7	10	32	6 x 40	A200001032612	1	2								
ZY 1032.06	NK 46 QU BA hard	10	32	6 x 40	A200001032627		2	3		5					
ZY 1040.06	EKR 60 N V4	10	40	6 x 40	A200001040602	1	2	3							
ZY 1040.06	NK 46 QU BA hard	10	40	6 x 40	A200001040627		2	3		5					
ZY 1313.03	EKR 46 N V4	13	13	3 x 30	A200001313302	1	2	3							
ZY 1313.03	EKWBR 60 O/P V7	13	13	3 x 30	A200001313312	1	2								
ZY 1313.03	RKD 60 P (6) V21	13	13	3 x 30	A200001313347		2	3	4						
ZY 1313.06	EKR 46 N V4	13	13	6 x 40	A200001313602	1	2	3							
ZY 1313.06	RKD 60 P (6) V21	13	13	6 x 40	A200001313647		2	3	4						
ZY 1320.06	EKR 46 N V4	13	20	6 x 40	A200001320602	1	2	3							
ZY 1320.06	EKR 46 QU V4	13	20	6 x 40	A2000013206020001	1	2	3							
ZY 1320.06	EKWBR 60 O/P V7	13	20	6 x 40	A200001320612	1	2								
ZY 1320.06	NK 46 QU BA hard	13	20	6 x 40	A200001320627		2	3		5					
ZY 1320.06	MK 46 N V10	13	20	6 x 40	A200001320616		2		4	5					
ZY 1325.06	EKR 46 N V4	13	25	6 x 40	A200001325602	1	2	3							
ZY 1325.06	RKD 60 QU V21	13	25	6 x 40	A200001325647		2	3	4						
ZY 1332.06	EKR 46 N V4	13	32	6 x 40	A200001332602	1	2	3							
ZY 1332.06	NK 24 N BA soft	13	32	6 x 40	A200001332627W		2	3	4		6				
ZY 1332.06	NK 46 QU BA hard	13	32	6 x 40	A200001332627		2	3		5					
ZY 1616.06	EKR 46 N V4	16	16	6 x 40	A200001616602	1	2	3							
ZY 1616.06	RKD 36 O (6) V21	16	16	6 x 40	A200001616647		2	3	4						
ZY 1620.06	EKR 46 N V4	16	20	6 x 40	A200001620602	1	2	3							
ZY 1620.06	EKWBR 46 O/P V7	16	20	6 x 40	A200001620612	1	2								
ZY 1620.06	NK 24 QU BA hard	16	20	6 x 40	A200001620627		2	3		5					
ZY 1632.06	EKR 46 N V4	16	32	6 x 40	A200001632602	1	2	3							
ZY 1632.06	EKWBR 46 O/P V7	16	32	6 x 40	A200001632612	1	2								
ZY 1632.06	RKD 36 O (6) V21	16	32	6 x 40	A200001632647		2	3	4						
ZY 1632.06	NK 24 N BA soft	16	32	6 x 40	A200001632627W		2	3	4		6				
ZY 1632.06	NK 24 QU BA hard	16	32	6 x 40	A200001632627		2	3		5					
ZY 1632.06	HK 30 N V13	16	32	6 x 40	A200001632633				4	5					
ZY 1632.06	MK 36 N V10	16	32	6 x 40	A200001632616		2		4	5					
ZY 1640.06	EKR 46 N V4	16	40	6 x 40	A200001640602	1	2	3							
ZY 1640.06	NK 24 QU BA hard	16	40	6 x 40	A200001640627		2	3		5					
ZY 1640.06	MK 36 N V 10	16	40	6 x 40	A200001640616		2		4	5					



Shape ZY, Cylinder, Type 1 (according to DIN 69170)

Ordering example: A200002013602

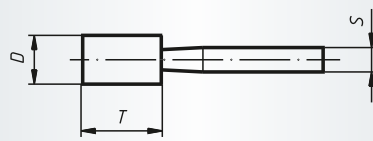

Packing unit:

20 pcs. per type

Further dimensions, qualities and shank lengths on request.

Description	Quality	D mm	T mm	S mm	Product-Number	recommended for															
ZY 2013.06	EKR 36 N V4	20	13	6 x 40	A200002013602	1	2	3													
ZY 2020.06	EKR 36 N V4	20	20	6 x 40	A200002020602	1	2	3													
ZY 2020.06	RKD 36 O (6) V21	20	20	6 x 40	A200002020647		2	3	4												
ZY 2020.06	NK 24 QU BA hard	20	20	6 x 40	A200002020627		2	3		5											
ZY 2020.06	MK 36 N V10	20	20	6 x 40	A200002020616		2		4	5											
ZY 2020.06	EKW 60 L V1	20	20	6 x 40	A200002020608			3					7		9						
ZY 2025.06	EKR 36 N V4	20	25	6 x 40	A200002025602	1	2	3													
ZY 2025.06	RKD 36 O (6) V21	20	25	6 x 40	A200002025647		2	3	4												
ZY 2025.06	HOK 0-3 V9	20	25	6 x 40	A202202025626										8						
ZY 2032.06	EKR 36 N V4	20	32	6 x 40	A200002032602	1	2	3													
ZY 2032.06	EKR 30/36 QU (7) V21	20	32	6 x 40	A2000020326020001	1	2	3													
ZY 2032.06	RKD 36 O (6) V21	20	32	6 x 40	A200002032647		2	3	4												
ZY 2032.06	NK 24 QU BA hard	20	32	6 x 40	A200002032627		2	3		5											
ZY 2032.06	HK 30 N V13	20	32	6 x 40	A200002032633				4	5											
ZY 2032.06	MK 36 N V10	20	32	6 x 40	A200002032616		2		4	5											
ZY 2040.06	EKR 36 N V4	20	40	6 x 40	A200002040602	1	2	3													
ZY 2040.06	EKWBR 46 O/P V7	20	40	6 x 40	A200002040612	1	2														
ZY 2040.06	RKD 36 O (6) V21	20	40	6 x 40	A200002040647		2	3	4												
ZY 2040.06	NK 24 N BA soft	20	40	6 x 40	A200002040627W		2	3	4		6										
ZY 2040.06	NK 24 QU BA hard	20	40	6 x 40	A200002040627		2	3		5											
ZY 2040.06	HK 30 N V13	20	40	6 x 40	A200002040633				4	5											
ZY 2040.06	MK 36 N V10	20	40	6 x 40	A200002040616		2		4	5											
ZY 2040.08	NK 24 N BA soft	20	40	8 x 40	A200002040827W		2	3	4		6										
ZY 2040.08	NK 24 QU BA hard	20	40	8 x 40	A200002040827		2	3		5											
ZY 2040.08	HK 30 N V13	20	40	8 x 40	A200002040833				4	5											
ZY 2520.06	EKR 36 N V4	25	20	6 x 40	A200002520602	1	2	3													
ZY 2525.06	EKR 36 N V4	25	25	6 x 40	A200002525602	1	2	3													
ZY 2525.06	RKD 30 O (6) V21	25	25	6 x 40	A200002525647		2	3	4												
ZY 2525.06	NK 24 QU BA hard	25	25	6 x 40	A200002525627		2	3		5											
ZY 2532.06	EKR 36 N V4	25	32	6 x 40	A200002532602	1	2	3													
ZY 2532.06	RKD 30 O (6) V21	25	32	6 x 40	A200002532647		2	3	4												
ZY 2532.06	NK 24 N BA soft	25	32	6 x 40	A200002532627W		2	3	4		6										
ZY 2532.06	NK 24 QU BA hard	25	32	6 x 40	A200002532627		2	3		5											
ZY 2532.06	HK 30 N V13	25	32	6 x 40	A200002532633				4	5											
ZY 2532.06	MK 36 N V10	25	32	6 x 40	A200002532616		2		4	5											
ZY 3220.06	EKR 30 N V4	32	20	6 x 40	A200003220602	1	2	3													
ZY 3220.06	NK 24 QU BA hard	32	20	6 x 40	A200003220627		2	3		5											
ZY 3220.06	MK 36 N V10	32	20	6 x 40	A200003220616		2		4	5											
ZY 3232.06	EKR 30 N V4	32	32	6 x 40	A200003232602	1	2	3													
ZY 3232.06	EKR 30/36 QU (7) V21	32	32	6 x 40	A2000032326020001	1	2	3													
ZY 3232.06	EKWBR 46 O/P V7	32	32	6 x 40	A200003232612	1	2														
ZY 3232.06	RKD 30 O (6) V21	32	32	6 x 40	A200003232647		2	3	4												



Shape ZY, Cylinder, Type 1 (according to DIN 69170)

Ordering example: A200003232627W

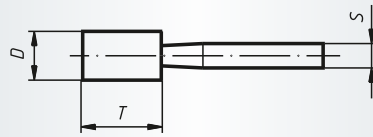

Packing unit:

20 pcs. per type

Further dimensions, qualities and shank lengths on request.

Description	Quality	D mm	T mm	S mm	Product-Number	recommended for														
ZY 3232.06	NK 24 N BA soft	32	32	6 x 40	A200003232627W	2	3	4	6											
ZY 3232.06	NK 24 QU BA hard	32	32	6 x 40	A200003232627	2	3		5											
ZY 3232.06	MK 36 N V10	32	32	6 x 40	A200003232616	2		4	5											
ZY 3240.06	EKR 30 N V4	32	40	6 x 40	A200003240602	1	2	3												
ZY 3240.06	RKD 30 O (6) V21	32	40	6 x 40	A200003240647		2	3	4											
ZY 3240.06	MK 36 N V10	32	40	6 x 40	A200003240616		2		4	5										
ZY 4020.06	EKR 30 N V4	40	20	6 x 40	A200004020602	1	2	3												
ZY 4020.06	RKD 24 O (6) V21	40	20	6 x 40	A200004020647		2	3	4											
ZY 4020.06	NK 24 N BA soft	40	20	6 x 40	A200004020627W		2	3	4	6										
ZY 4020.06	NK 24 QU BA hard	40	20	6 x 40	A200004020627		2	3		5										
ZY 4020.06	HK 30 N V13	40	20	6 x 40	A200004020633				4	5										
ZY 4020.06	MK 36 N V10	40	20	6 x 40	A200004020616		2		4	5										
ZY 4020.06	HOK 0-3 V9	40	20	6 x 40	A202204020626														8	
ZY 4020.08	RKD 24 O (6) V21	40	20	8 x 40	A200004020847		2	3	4											
ZY 4020.08	NK 24 N BA soft	40	20	8 x 40	A200004020827W		2	3	4	6										
ZY 4020.08	NK 24 QU BA hard	40	20	8 x 40	A200004020827		2	3		5										
ZY 4020.08	HK 30 N V13	40	20	8 x 40	A200004020833				4	5										
ZY 4040.06	EKR 30 N V4	40	40	6 x 40	A200004040602	1	2	3												
ZY 4040.06	RKD 24 O (6) V21	40	40	6 x 40	A200004040647		2	3	4											
ZY 4040.08	RKD 24 O (6) V21	40	40	8 x 40	A200004040847		2	3	4											
ZY 4040.08	NK 24 QU BA hard	40	40	8 x 40	A200004040827		2	3		5										
ZY 4040.08	MK 36 N V10	40	40	8 x 40	A200004040816		2		4	5										
ZY 5013.08	NK 24 QU BA hard	50	13	8 x 40	A200005013827		2	3		5										
ZY 5020.06	EKR 30 N V4	50	20	6 x 40	A200005020602	1	2	3												
ZY 5020.06	RKD 24 O (6) V21	50	20	6 x 40	A200005020647		2	3	4											
ZY 5020.06	NK 24 N BA soft	50	20	6 x 40	A200005020627W		2	3	4	6										
ZY 5020.06	NK 24 QU BA hard	50	20	6 x 40	A200005020627		2	3		5										
ZY 5020.08	NK 24 QU BA hard	50	20	8 x 40	A200005020827		2	3		5										
ZY 5025.06	MK 30 N V10	50	25	6 x 40	A200005025616		2		4	5										
ZY 5025.08	NK 24 QU BA hard	50	25	8 x 40	A200005025827		2	3		5										



Shape ZY, Cylinder, Type 2 (according to DIN 69170)

Ordering example: A201301303377

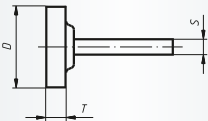
					<p>Packing unit: 20 pcs. per type Further dimensions, qualities and shank lengths on request.</p>	
Description	Quality	D mm	T mm	S mm	Product-Number	recommended for
ZY2 1303.03	CERAMIC 80 L V118	13	3	3 x 30	A201301303377	② ③ ④ ⑦



Shape ZY, Cylinder, Type 2 (according to DIN 69170)

Ordering example: A201301303302

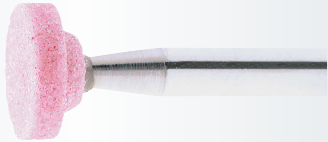
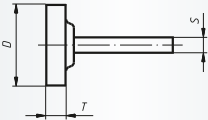
					<p>Packing unit: 20 pcs. per type Further dimensions, qualities and shank lengths on request.</p>	
Description	Quality	D mm	T mm	S mm	Product-Number	recommended for
ZY2 1303.03	EKR 80 N V4	13	3	3 x 30	A201301303302	① ② ③
ZY2 1303.03	EKWBR 80 O/P V7	13	3	3 x 30	A201301303312	① ②
ZY2 1303.03	RKD 80 QU V21	13	3	3 x 30	A201301303347	② ③ ④
ZY2 1303.06	EKR 80 N V4	13	3	6 x 40	A201301303602	① ② ③
ZY2 1604.03	EKR 60 N V4	16	4	3 x 30	A201301604302	① ② ③
ZY2 1604.03	EKWBR 60 O/P V7	16	4	3 x 30	A201301604312	① ②
ZY2 1604.03	RKD 80 QU V21	16	4	3 x 30	A201301604347	② ③ ④
ZY2 1604.06	EKR 60 N V4	16	4	6 x 40	A201301604602	① ② ③
ZY2 2006.03	EKR 60 N V4	20	6	3 x 30	A201302006302	① ② ③
ZY2 2006.03	EKWBR 60 O/P V7	20	6	3 x 30	A201302006312	① ②
ZY2 2006.06	EKR 60 N V4	20	6	6 x 40	A201302006602	① ② ③
ZY2 2006.06	EKR 46 QU V4	20	6	6 x 40	A2013020066020001	① ② ③
ZY2 2506.06	EKR 60 N V4	25	6	6 x 40	A201302506602	① ② ③
ZY2 2510.06	EKR 36 N V4	25	10	6 x 40	A201302510602	① ② ③
ZY2 2510.06	NK 24 QU BA. hard	25	10	6 x 40	A201302510627	② ③ ⑤
ZY2 3208.06	EKR 46 N V4	32	8	6 x 40	A201303208602	① ② ③
ZY2 3208.06	RKD 36 O (6) V21	32	8	6 x 40	A201303208647	② ③ ④
ZY2 3208.06	NK 24 QU BA. hard	32	8	6 x 40	A201303208627	② ③ ⑤
ZY2 4006.06	NK 24 N BA. soft	40	10	6 x 40	A201304006627	② ③ ④ ⑥
ZY2 4010.06	EKR 30 N V4	40	10	6 x 40	A201304010602	① ② ③
ZY2 4010.06	RKD 30 O (6) V21	40	10	6 x 40	A201304010647	② ③ ④
ZY2 4010.06	NK 24 N BA. soft	40	10	6 x 40	A201304010627W	② ③ ④ ⑥
ZY2 4010.06	NK 24 QU BA. hard	40	10	6 x 40	A201304010627	② ③ ⑤
ZY2 4010.06	MK 36 N V10	40	10	6 x 40	A201304010616	② ④ ⑤
ZY2 5004.06	NK 24 N BA. soft	50	4	6 x 40	A201305004627W	② ③ ④ ⑥
ZY2 5004.06	NK 24 QU BA. hard	50	4	6 x 40	A201305004627	② ③ ⑤
ZY2 5006.06	NK 24 N BA. soft	50	6	6 x 40	A201305006627W	② ③ ④ ⑥



Industry

Shape ZY, Cylinder, Type 2 (according to DIN 69170)

Ordering example: A201305006627

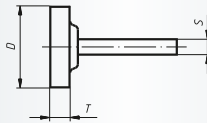
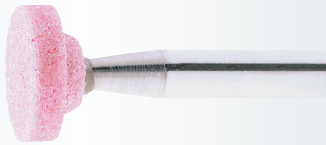

Packing unit:

20 pcs. per type

Further dimensions, qualities and shank lengths on request.

Description	Quality	D mm	T mm	S mm	Product-Number	recommended for	
ZY2 5006.06	NK 24 QU BA. hard	50	6	6 x 40	A201305006627	② ③ ⑤	■
ZY2 5010.06	EKR 30 N V4	50	10	6 x 40	A201305010602	① ② ③	■
ZY2 5010.06	NK 24 N BA. soft	50	10	6 x 40	A201305010627W	② ③ ④ ⑥	■
ZY2 5010.06	NK 24 QU BA. hard	50	10	6 x 40	A201305010627	② ③ ⑤	■
ZY2 5010.06	HK 30 N V13	50	10	6 x 40	A201305010633	④ ⑤	■
ZY2 5010.08	NK 24 N BA. soft	50	10	8 x 40	A201305010827W	② ③ ④ ⑥	■
ZY2 5010.08	NK 24 QU BA. hard	50	10	8 x 40	A201305010827	② ③ ⑤	■
ZY2 6510.08	NK 24 P BA.15	65	10	8 x 40	A201306510827	② ③ ⑤	■



Industry

Shape WKS, Cylindrical pointed nose

Ordering example: A200402025602

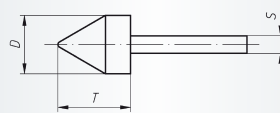

Packing unit:

20 pcs. per type

Further dimensions, qualities and shank lengths on request.

Description	Quality	D mm	T mm	S mm	Product-Number	recommended for	
WKS 2025.06	EKR 60 N V4	20	25	6 x 40	A200402025602	① ② ③	■



High Performance

Shape SP, Pointed nose (according to DIN 69170)

Ordering example: A200200510377

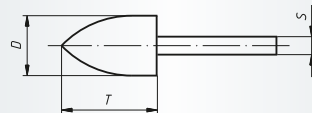

Packing unit:

20 pcs. per type

Further dimensions, qualities and shank lengths on request.

Description	Quality	D mm	T mm	S mm	Product-Number	recommended for	
SP 0510.03	CERAMIC 80 L V118	5	10	3 x 30	A200200510377	② ③ ④ ⑦	■
SP 0816.03	CERAMIC 80 L V118	8	16	3 x 30	A200200816377	② ③ ④ ⑦	■
SP 1320.06	CERAMIC 46 L V118	13	20	6 x 40	A200201320677	② ③ ④ ⑦	■

114 Mounted points



High Performance

Shape SP, Pointed nose (according to DIN 69170)

Ordering example: A2002005103530001

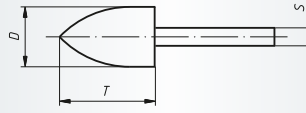

Packing unit:

20 pcs. per type

Further dimensions, qualities and shank lengths on request.

Description	Quality	D mm	T mm	S mm	Product-Number	recommended for																
SP 0510.03	NDW 100 QU V115	5	10	3 x 30	A2002005103530001	②	③															■
SP 0510.03	NDW 100 QU V115	5	10	3 x 50	A200200510353	②	③															■
SP 0810.03	NDW 100 QU V115	8	10	3 x 30	A2002008103530001	②	③															■
SP 0810.03	NDW 100 QU V115	8	10	3 x 50	A200200810353	②	③															■



Industry

Shape SP, Pointed nose (according to DIN 69170)

Ordering example: A200200306302

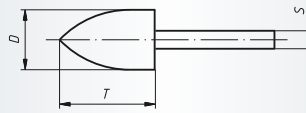

Packing unit:

20 pcs. per type

Further dimensions, qualities and shank lengths on request.

Description	Quality	D mm	T mm	S mm	Product-Number	recommended for																
SP 0306.03	EKR 100 N V4	3	6	3 x 30	A200200306302	①	②	③														■
SP 0306.03	RKD 120 QU V21	3	6	3 x 30	A200200306347		②	③	④													■
SP 0510.03	EKR 80 N V4	5	10	3 x 30	A200200510302	①	②	③														■
SP 0510.03	RKD 100 QU V21	5	10	3 x 30	A200200510347		②	③	④													■
SP 0510.06	EKR 80 N V4	5	10	6 x 40	A200200510602	①	②	③														■
SP 0816.03	EKR 60 N V4	8	16	3 x 30	A200200816302	①	②	③														■
SP 0816.03	RKD 80 QU V21	8	16	3 x 30	A200200816347		②	③	④													■
SP 0816.06	EKR 60 N V4	8	16	6 x 40	A200200816602	①	②	③														■
SP 1020.06	EKR 60 N V4	10	20	6 x 40	A200201020602	①	②	③														■
SP 1320.06	EKR 46 N V4	13	20	6 x 40	A200201320602	①	②	③														■
SP 2032.06	EKR 36 N V4	20	32	6 x 40	A200202032602	①	②	③														■



High Performance

Shape WR, Cylindrical round nose (according to DIN 69170)

Ordering example: A2014010133530001

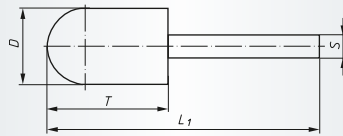

Packing unit:
20 pcs. per type
Further dimensions, qualities and shank lengths on request.

Description	Quality	D mm	T mm	S mm	Product-Number	recommended for	
WR 1013.03	NDW 100 QU V115	10	13	3 x 30	A2014010133530001	② ③	■
WR 1013.03	NDW 100 QU V115	10	13	3 x 50	A201401013353	② ③	■



High Performance

Shape KU, Spherical (according to DIN 69170)

Ordering example: A201100606377

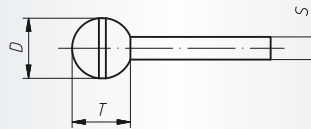

Packing unit:
20 pcs. per type
Further dimensions, qualities and shank lengths on request.

Description	Quality	D mm	T mm	S mm	Product-Number	recommended for	
KU 0606.03	CERAMIC 80 L V118	6	6	3 x 30	A201100606377	② ③ ④ ⑦	■
KU 1010.06	CERAMIC 46 L V118	10	10	6 x 40	A201101010677	② ③ ④ ⑦	■
KU 1313.06	CERAMIC 46 L V118	13	13	6 x 40	A201101313677	② ③ ④ ⑦	■



High Performance

Shape KU, Spherical (according to DIN 69170)

Ordering example: A2011004043530001

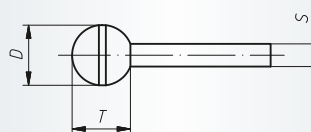

Packing unit:
20 pcs. per type
Further dimensions, qualities and shank lengths on request.

Description	Quality	D mm	T mm	S mm	Product-Number	recommended for	
KU 0404.03	NDW 100 QU V115	4	4	3 x 30	A2011004043530001	② ③	■
KU 0404.03	NDW 100 QU V115	4	4	3 x 50	A201100404353	② ③	■
KU 0606.03	NDW 100 QU V115	6	6	3 x 30	A2011006063530001	② ③	■
KU 0606.03	NDW 100 QU V115	6	6	3 x 50	A201100606353	② ③	■
KU 0808.03	NDW 100 QU V115	8	8	3 x 30	A2011008083530001	② ③	■
KU 0808.03	NDW 100 QU V115	8	8	3 x 50	A201100808353	② ③	■



Shape KU, Spherical (according to DIN 69170)

Ordering example: A201100606302

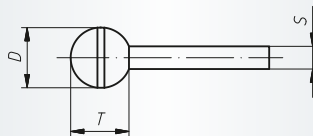

Packing unit:

20 pcs. per type

Further dimensions, qualities and shank lengths on request.

Description	Quality	D mm	T mm	S mm	Product-Number	recommended for												
KU 0606.03	EKR 60 N V4	6	6	3 x 30	A201100606302	1	2	3										
KU 0606.03	EKR 80/100 QU V4	6	6	3 x 30	A2011006063020001	1	2	3										
KU 0606.03	EKWBR. 60 O/P V7	6	6	3 x 30	A201100606312	1	2											
KU 0606.06	EKR 60 N V4	6	6	6 x 40	A201100606602	1	2	3										
KU 0606.06	EKWBR. 60 O/P V7	6	6	6 x 40	A201100606612	1	2											
KU 0808.03	EKR 60 N V4	8	8	3 x 30	A201100808302	1	2	3										
KU 0808.03	EKWBR. 60 O/P V7	8	8	3 x 30	A201100808312	1	2											
KU 0808.06	EKR 60 N V4	8	8	6 x 40	A201100808602	1	2	3										
KU 0808.06	EKR 60/80 QU V4	8	8	6 x 40	A2011008086020001	1	2	3										
KU 1010.03	EKR 60 N V4	10	10	3 x 30	A201101010302	1	2	3										
KU 1010.03	EKWbr. 60 O/P V7	10	10	3 x 30	A201101010312	1	2											
KU 1010.03	RKD 80 P V21	10	10	3 x 30	A201101010347		2	3	4									
KU 1010.06	EKR 60 N V4	10	10	6 x 40	A201101010602	1	2	3										
KU 1313.03	EKR 46 N V4	13	13	3 x 30	A201101313302	1	2	3										
KU 1313.06	EKR 46 N V4	13	13	6 x 40	A201101313602	1	2	3										
KU 1313.06	EKR 46 QU V4	13	13	6 x 40	A2011013136020001	1	2	3										
KU 1616.06	EKR 46 N V4	16	16	6 x 40	A201101616602	1	2	3										
KU 1616.06	RKD 60 P (6) V21	16	16	6 x 40	A201101616647		2	3	4									
KU 2020.06	EKR 36 N V4	20	20	6 x 40	A201102020602	1	2	3										
KU 2020.06	EKR 60 P V21	20	20	6 x 40	A2011020206020001	1	2	3										
KU 2020.06	EKWBR. 46 O/P V7	20	20	6 x 40	A201102020612	1	2											
KU 2525.06	EKR 36 N V4	25	25	6 x 40	A201102525602	1	2	3										
KU 2525.06	RKD 30 QU V21	25	25	6 x 40	A201102525647		2	3	4									
KU 2525.06	NK 24 N Ba. soft	25	25	6 x 40	A201102525627		2	3	4		6							
KU 2525.06	HOK 0-3 V9	25	25	6 x 40	A201902525626												8	
KU 3232.06	EKR 30 N V4	32	32	6 x 40	A201103232602	1	2	3										
KU 3838.06	HOK 0-3 V9	38	38	6 x 40	A201903838626													8



Industry

Shape TO, Cup (according to DIN 69170)

Ordering example: A202002019602

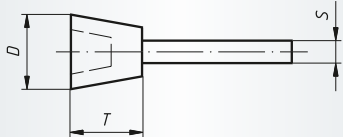
					<p>Packing unit: 20 pcs. per type</p> <p>Further dimensions, qualities and shank lengths on request.</p>							
Description	Quality	D mm	T mm	S mm	Product-Number	recommended for						
TO 2020.06	EKR 60 N V4	20	20	6 x 40	A202002019602	①	②	③				■
TO 2524.06	EKR 60 N V4	25	24	6 x 40	A202002524602	①	②	③				■
TO 3229.06	EKR 60 N V4	32	29	6 x 40	A202003229602	①	②	③				■
TO 4036.06	EKR 60 N V4	40	36	6 x 40	A202004036602	①	②	③				■



High Performance

Shape KE, Conical round nose (according to DIN 69170)

Ordering example: A201501025677

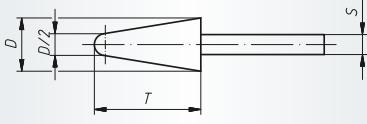
					<p>Packing unit: 20 pcs. per type</p>							
Description	Quality	D mm	T mm	S mm	Product-Number	recommended for						
KE 1025.06	CERAMIC 46 L V118	10	25	6 x 40	A201501025677		②	③	④		⑦	■
KE 1632.06	CERAMIC 46 L V118	16	32	6 x 40	A201501632677		②	③	④		⑦	■



High Performance

Shape KE, Conical round nose (according to DIN 69170)

Ordering example: A201501632618A

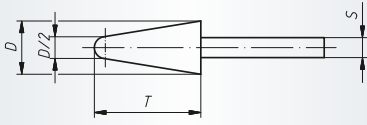
					<p>Packing unit: 20 pcs. per type</p>							
Description	Quality	D mm	T mm	S mm	Product-Number	recommended for						
KE 1632.06	SIC-ALU 80 V27 W	16	32	6 x 40	A201501632618A						⑥	■
KE 2040.06	SIC-ALU 80 V27 W	20	40	6 x 40	A201502040618A						⑥	■

118 Mounted points



Industry

Shape KE, Conical round nose (according to DIN 69170)

Ordering example: A201501025647

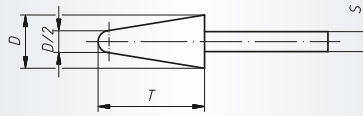
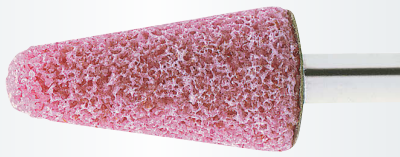

Packing unit:

20 pcs. per type

Further dimensions, qualities and shank lengths on request.

Description	Quality	D mm	T mm	S mm	Product-Number	recommended for															
KE 1025.06	RKD 60 P (6) V21	10	25	6 x 40	A201501025647		②	③	④												■
KE 1025.06	EKRBR.46/60 P V7	10	25	6 x 40	A201601025606	①															■
KE 1632.06	EKR 46 N V4	16	32	6 x 40	A201501632602	①	②	③													■
KE 1632.06	MK 36 N V10	16	32	6 x 40	A201501632616		②		④	⑤											■
KE 1640.06	EKR 46 N V4	16	40	6 x 40	A201501640602	①	②	③													■
KE 1645.06	RKD 46 O V13	16	45	6 x 40	A2015016456470002		②	③	④												■
KE 1645.06	EKRBR.46/60 P V7	16	45	6 x 40	A201601645606	①															■
KE 2032.06	EKR 36 N V4	20	32	6 x 40	A201502032602	①	②	③													■
KE 2032.06	MK 36 N V10	20	32	6 x 40	A201502032616		②		④	⑤											■
KE 2040.06	EKR 36 N V4	20	40	6 x 40	A201502040602	①	②	③													■
KE 2040.06	RKD 36 O (6) V21	20	40	6 x 40	A201502040647		②	③	④												■
KE 2040.06	MK 36 N V10	20	40	6 x 40	A201502040616		②		④	⑤											■
KE 2570.06	EKR 36 N V4	25	70	6 x 40	A201502570602	①	②	③													■
KE 3250.06	RKD 30 O (6) V21	32	50	6 x 40	A201503250647		②	③	④												■
KE 3250.08	HK 30 N V13	32	50	8 x 40	A201503250833				④	⑤											■



Industry

Shape A, american shapes

Ordering example: A2062022636020001

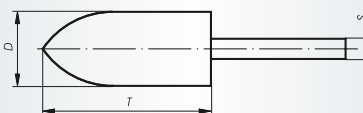

Packing unit:

20 pcs. per type

Further dimensions, qualities and shank lengths on request.

Description	Quality	Shape	D inch	T inch	D mm	T mm	S mm	Product-Number	recommended for													
A1 2263.06	EKR 36 N V4		7/8	2 1/2	22	63	6 x 40	A2062022636020001	①	②	③											■
A1 2263.06	HK 36/46 M V13		7/8	2 1/2	22	63	6 x 40	A206202263633				④	⑤									■
A2 2532.06	EKR 36 QU V4		1	1 1/4	25	32	6 x 40	A206202532602	①	②	③											■
AS-3 1645.06	HK 36/46 M V13		5/8	1 3/4	16	45	6 x 40	A206201645633				④	⑤									■
A3 2570.06	EKR 36 N V4		1	2 3/4	25	70	6 x 40	A2062025706020001	①	②	③											■
A3 2570.06	HK 36/46 M V13		1	2 3/4	25	70	6 x 40	A206202570633				④	⑤									■
A3 2570.08	HK 36/46 M V13		1	2 3/4	25	70	8 x 40	A206402570833				④	⑤									■

120 Mounted points



Industry

Shape B, american shapes

Ordering example: A206601616302

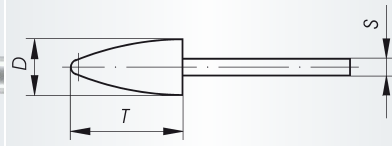

Packing unit:

20 pcs. per type

Further dimensions, qualities and shank lengths on request.

Description	Quality	Shape	D inch	T inch	D mm	T mm	S mm	Product-Number	recommended for	
B41 1616.03	EKR 60/80 QU V4		5/8	5/8	16	16	3 x 30	A206601616302	① ② ③	■
B52 1020.03	EKR 46 QU V4		3/8	3/4	10	20	3 x 30	A206601020302	① ② ③	■
B53 0816.03	EKR 60/80 QU V4		5/16	5/8	8	16	3 x 30	A206600816302	① ② ③	■



Industry

Miniature-Mounted points

Ordering example: A202900001302

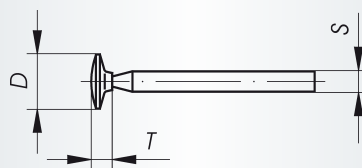

Packing unit:

20 pcs. per type

Further dimensions, qualities and shank lengths on request.

Description	Quality	Shape	D mm	T mm	S mm	Product-Number	recommended for	
D1	EKR 100 N V4		9	2	3 x 30	A202900001302	① ② ③	■
D1	EKBR 100 M V1/6		9	2	3 x 30	A202900001311	② ③	■
D2	EKR 80 N V4		9	3	3 x 30	A202900002302	① ② ③	■
D2	EKBR 80 M V1/6		9	3	3 x 30	A202900002311	② ③	■
D3	EKR 100 N V4		8	2	3 x 30	A202900003302	① ② ③	■
D3	EKBR 100 M V1/6		8	2	3 x 30	A202900003311	② ③	■
D4	EKR 100 N V4		4	1	3 x 30	A202900004302	① ② ③	■
D4	EKBR 100 M V1/6		4	1	3 x 30	A202900004311	② ③	■
D5	EKR 80 N V4		5	3	3 x 30	A202900005302	① ② ③	■
D5	EKBR 80 M V1/6		5	3	3 x 30	A202900005311	② ③	■
D6	EKR 80 N V4		7/4	6	3 x 30	A202900006302	① ② ③	■



Miniature-Mounted points

Ordering example: A202900007302

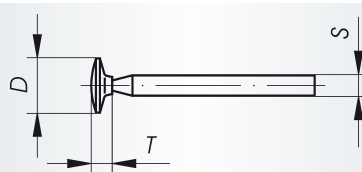

Packing unit:
20 pcs. per type
Further dimensions, qualities and
shank lengths on request.

Description	Quality	Shape	D mm	T mm	S mm	Product-Number	recommended for															
D7	EKR 100 N V4		2,5/5	2,5	3 x 30	A202900007302	1	2	3													
D7	EKBR 100 M V1/6		2,5/5	2,5	3 x 30	A202900007311			2	3												
D8	EKR 100 N V4		2,5/6	3	3 x 30	A202900008302	1	2	3													
D8	EKBR 100 M V1/6		2,5/6	3	3 x 30	A202900008311			2	3												
D9	EKR 80 N V4		3,5/8	4	3 x 30	A202900009302	1	2	3													
D9	EKBR 80 M V1/6		3,5/8	4	3 x 30	A202900009311			2	3												
D10	EKR 100 N V4		2/3,2	4	3 x 30	A202900010302	1	2	3													
D10	EKBR 100 M V1/6		2/3,2	4	3 x 30	A202900010311			2	3												
D11	EKR 80 N V4		5	5	3 x 30	A202900011302	1	2	3													
D12	EKR 80 N V4		4/7	6	3 x 30	A202900012302	1	2	3													
D12	EKBR 80 M V1/6		4/7	6	3 x 30	A202900012311			2	3												
D13	EKR 100 N V4		3	3	3 x 30	A202900013302	1	2	3													
D13	EKBR. 100 M V1/6		3	3	3 x 30	A202900013311			2	3												
D14	EKR 80 N V4		4	4	3 x 30	A202900014302	1	2	3													
D14	EKBR 80 M V1/6		4	4	3 x 30	A202900014311			2	3												
D15	EKR 80 N V4		5	5	3 x 30	A202900015302	1	2	3													
D15	EKBR 80 M V1/6		5	5	3 x 30	A202900015311			2	3												
D16	EKR 100 N V4		3	4	3 x 30	A202900016302	1	2	3													
D16	EKBR 100 M V1/6		3	4	3 x 30	A202900016311			2	3												
D17	EKR 80 N V4		4	5	3 x 30	A202900017302	1	2	3													
D17	EKBR 80 M V1/6		4	5	3 x 30	A202900017311			2	3												

122 Mounted points



Industry

Miniature-Mounted points

Ordering example: A202900018302

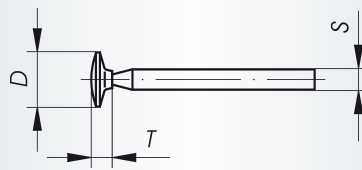

Packing unit:
20 pcs. per type
Further dimensions, qualities and
shank lengths on request.

Description	Quality	Shape	D mm	T mm	S mm	Product-Number	recommended for															
D18	EKR 80 N V4		7	8	3 x 30	A202900018302	①	②	③													■
D18	EKBR 80 M V1/6		7	8	3 x 30	A202900018311		②	③													■
D20	EKR 100 N V4		7	5	3 x 30	A202900020302	①	②	③													■
D21	EKR 100 N V4		8	1,6	3 x 30	A202900021302	①	②	③													■
D21	EKBR 100 M V1/6		8	1,6	3 x 30	A202900021311		②	③													■
D22	EKR 100 N V4		2,5	6	3 x 30	A202900022302	①	②	③													■
D22	EKBR 100 M V1/6		2,5	6	3 x 30	A202900022311		②	③													■
D23	EKR 80 N V4		5	6	3 x 30	A202900023302	①	②	③													■
D23	EKBR 80 M V1/6		5	6	3 x 30	A202900023311		②	③													■
D24	EKR 60 N V4		6	6	3 x 30	A202900024302	①	②	③													■
D24	EKBR 60 M 1/6		6	6	3 x 30	A202900024311		②	③													■
D25	EKR 100 N V4		5	1,5	3 x 30	A202900025302	①	②	③													■
D26	EKR 100 N V4		6	2,5	3 x 30	A202900026302	①	②	③													■
D26	EKBR 100 M V1/6		6	2,5	3 x 30	A202900026311		②	③													■
D27	EKR 100 N V4		2/3,5	10	3 x 30	A202900027302	①	②	③													■
D28	EKR 80 N V4		3,5/5,5	11	3 x 30	A202900028302	①	②	③													■
D29	EKR 100 N V4		3	6,4	3 x 30	A202900029302	①	②	③													■
D29	EKBR 100 M V1/6		3	6,4	3 x 30	A202900029311		②	③													■
D30	EKR 100 N V4		4,4	10	3 x 30	A202900030302	①	②	③													■
D30	EKBR 100 M V1/6		4,4	10	3 x 30	A202900030311		②	③													■



Miniature-Mounted points

Ordering example: A202900032302

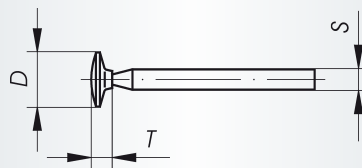

Packing unit:

20 pcs. per type

Further dimensions, qualities and shank lengths on request.

Description	Quality	Shape	D mm	T mm	S mm	Product-Number	recommended for														
D32	EKR 100 N V4		5	7	3 x 30	A202900032302	①	②	③												■
D32	EKBR 100 M V1/6		5	7	3 x 30	A202900032311		②	③												■
D33	EKR 80 N V4		6	8	3 x 30	A202900033302	①	②	③												■
D33	EKBR 80 M V1/6		6	8	3 x 30	A202900033311		②	③												■
D34	EKR 100 N V4		4,37	7	3 x 30	A202900034302	①	②	③												■
D34	EKBR 100 M V1/6		4,37	7	3 x 30	A202900034311		②	③												■
D35	EKR 80 N V4		6	10	3 x 30	A202900035302	①	②	③												■
D35	EKBR 80 M V1/6		6	10	3 x 30	A202900035311		②	③												■
D36	EKR 80 N V4		6	11	3 x 30	A202900036302	①	②	③												■
D36	EKBR 80 M V1/6		6	11	3 x 30	A202900036311		②	③												■



Handstones

Ordering example: A204300000118

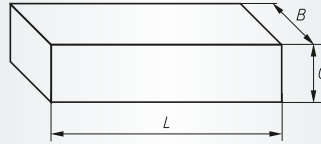

Packing unit:

5 pcs. per type

Further dimensions (see table below) and qualities on request.

Description	Quality	L mm	B mm	C mm	Product-Number	recommended for																		
RU 1	SICGR 60 O V23/green=fine	50	25	15	A204300000118																	9	■	
RU 1	SICDKL 24 O V23/dark=coarse	50	25	15	A204300000122																		9	■
RU 2	SICGR 60 O V23/green=fine	100	30	15	A204300000218																		9	■
RU 2	SICDKL 24 O V23/dark=coarse	100	30	15	A204300000222																		9	■
RU 3	SICGR 60 O V23/green=fine	100	50	25	A204300000318																		9	■
RU 3	SICDKL 24 O V23/dark=coarse	100	50	25	A204300000322																		9	■
RU 4	SICGR 60 O V23/green=fine	150	50	25	A204300000418																		9	■
RU 4	SICDKL 24 O V23/dark=coarse	150	50	25	A204300000422																		9	■
RU 5	EKW 100 E (9) V40	150	25	16,5	A2043150251608																		3	■
RU 6	EKW 100 E (9) V40	200	50	25	A2043200502508																		3	■

RU 1-4 is particularly suitable for

- profiling
 - opening of pores
 - sharpening
 - dressing
- of bonded grinding and polishing tools.

Available dimensions for handstones

Shape	length mm	width mm	height mm
	25	15	5 to 30
	44	35	18 to 30
	48	19	5 to 30
	50	25	10 to 35
	90	70	20 to 35
	100	30	10 to 35
	100	50	10 to 35
	120	10	5 to 35
	150	25	10 to 35
	150	50	10 to 35
	200	50	10 to 35
	216	78	20 to 35
	150	13	5 to 35



High Performance

Mounted points-Assortments

Ordering example: A201000000353



Packing unit:
1 pc. per type

Description	Shank Ø mm	Quality	Contents	1 piece each	Product-Number	recommended for	
Assortment 10	3 x 50	NDW	10-pieces	ZY 0408, ZY 0610, ZY 0810, ZY 1013, SP 0510, SP 0810, KU 0404, KU 0606, KU 0808, WR 1013	A201000000353	② ③	■



Industry

Mounted points-Assortments

Ordering example: A204700001402

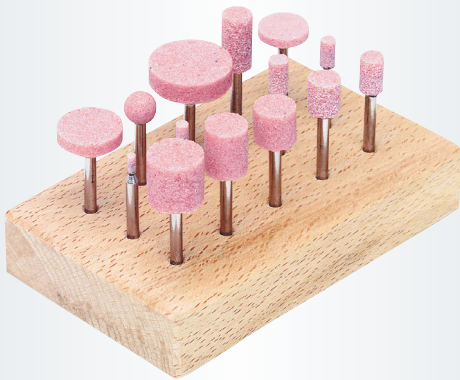

Packing unit:
1 pc. per type

Description	Shank Ø mm	Quality	Contents	1 piece each	Product-Number	recommended for	
Assortment 14	3 x 30	EKR	14-pieces	ZY 0205, ZY 0306, ZY 0408, ZY 0510, ZY 0610, ZY 0810, ZY 0816, ZY 1010, ZY 1013, ZY 1313, KU 0808, ZY2 1303, ZY2 1604, ZY2 2006	A204700001402	① ② ③	■

126 Mounted points-Assortments



Industry

Mounted points-Assortments

Ordering example: A204800003602

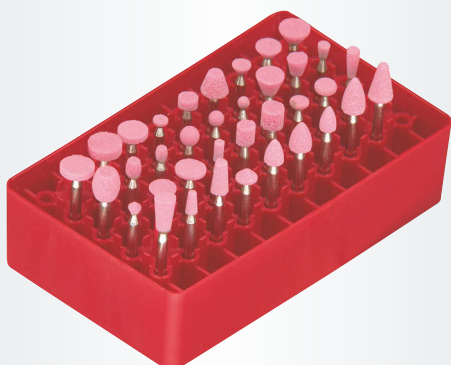

Packing unit:
1 pc. per type

Description	Shank Ø mm	Quality	Contents	1 piece each	Product-Number	recommended for	
Assortment 36	3 x 30	EKR	36-pieces	D1, D2, D3, D4, D5, D6, D7, D8, D9, D10, D11, D12, D13, D14, D15, D16, D17, D18, D19, D20, D21, D22, D23, D24, D25, D26, D27, D28, D29, D30, D31, D32, D33, D34, D35, D36	A204800003602	① ② ③	■



Industry

Mounted points-Assortments

Ordering example: A204800003611

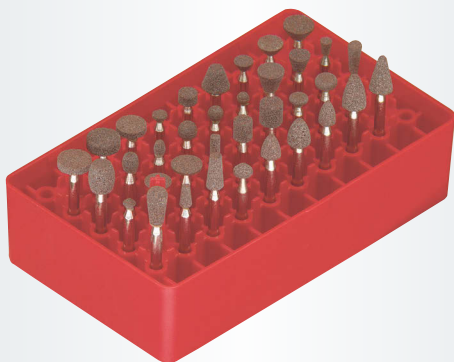

Packing unit:
1 pc. per type

Description	Shank Ø mm	Quality	Contents	1 piece each	Product-Number	recommended for	
Assortment 36	3 x 30	EKBR	36-pieces	D1, D2, D3, D4, D5, D6, D7, D8, D9, D10, D11, D12, D13, D14, D15, D16, D17, D18, D19, D20, D21, D22, D23, D24, D25, D26, D27, D28, D29, D30, D31, D32, D33, D34, D35, D36	A204800003611	② ③	■



Industry

Mounted points-Assortments

Ordering example: A204600000202



Packing unit:
1 pc. per type

Description	Shank Ø mm	Quality	Contents	1 piece each	Product-Number	recommended for	
Assortment 45	6 x 40	EKR	45-pieces	ZY 0306, ZY 0510, ZY 0408, ZY 0610, ZY 0810, ZY 0816, ZY 1010, ZY 1020, ZY 1032, ZY2 1303, ZY 1313, ZY 1320, ZY2 1604, ZY 1616, ZY 1620, ZY 1632, ZY2 2006, ZY 2020, ZY 2025, ZY 2032, ZY 2040, ZY2 2506, ZY2 2510, ZY 2520, ZY 2525, ZY 2532, ZY2 3208, ZY 3220, ZY 3232, ZY2 4010, ZY 4020, SP 0816, SP 1020, SP 1320, SP 2032, KE 1632, KE 1640, KE 2032, KE 2040, KU 1010, KU 1313, KU 1616, KU 2020, KU 2525, KU 3232	A204600000202	① ② ③	■

128 Mounted points-Assortments



Industry

Mounted point assortment – STEEL

Ordering example: A20480005602



Packing unit:
1 pc. per type

Description	Shank Ø mm	Quality	Contents	1 piece each	Product-Number	recommended for	
Assortment STAHL	6	EKR	5-pieces	ZY 1632.06, EKR 46 N V4, ZY 2525.06, EKR 36 N V4, WKS 2025.06, EKR 60 N V4, KU 2525.06, EKR 36 N V4, KE 1632.06, EKR 46 N V4	A20480005602	① ② ③	■



Industry

Mounted point assortment – INOX

Ordering example: A20480004627W



Packing unit:
1 pc. per type

Description	Shank Ø mm	Quality	Contents	1 piece each	Product-Number	recommended for	
Assortment INOX	6	NK BA	4-pieces	ZY 1332.06, NK 24 N BA Soft, ZY 2040.06, NK 24 N BA Soft, ZY2 4006.06, NK 24 N BA Soft, KU 2525.06, NK/NK 24 R BA 98	A20480004627W	② ③ ④ ⑥	■

Always the right tool

Polishing tools P6: The new LUKAS polishing wheels will brighten up your workpieces. See for yourself how fast and steady surfaces of the most different materials can be dash-dot matted or polished in accordance with your requests.

Holger Roland
Production



Grinding wheels – special for your particular application

131 Examples of our efficiency

131 Enquiry parameters

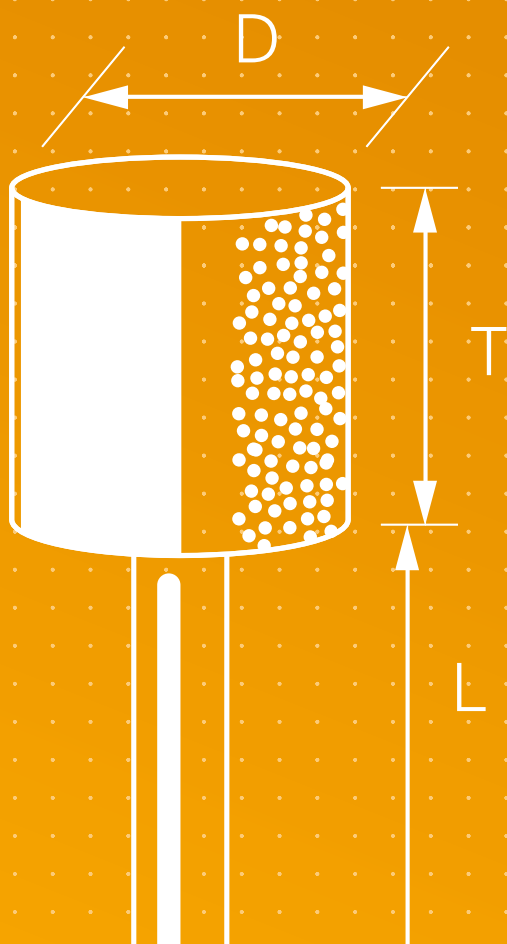
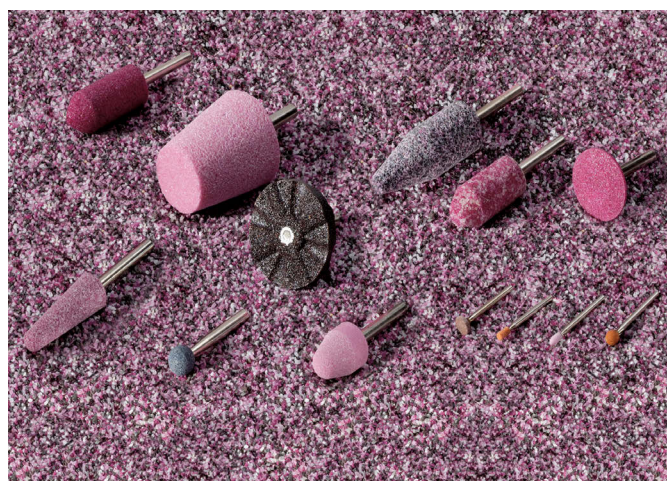

We are pleased to be able to offer you a “tailor-made” grinding wheel quality e.g.:

- Wheels in special qualities
- Wheels with special dimensions
- Wheels with special profiles
- Mounted points with imperial dimensions and/or imperial shafts
- Mounted points with internal threads and threaded shafts to suit
- Cup wheels
- Grinding wheels – plain and tapered
- Mounted points with extended shafts
- Mounted points with threaded shafts and extended shafts to suit
- Handstones and dressing sticks
- and much more

Please advise us of your application problem with all relevant information – the quicker this is done, the quicker we can react!
The relevant information required is:

- Shape, dimensions, shaft, bore size of the abrasive wheel (a sketch or technical drawing would be of great assistance)
- Material to be ground
- Type of application (e.g. fettling, deburring)
- Surface finish requirements
- Machine R.P.M
- anticipated order quantity
- wheel currently being used (type, quality...)
- etc.

Always the right tool

For Highest Performance and Best Ergonomics!



Polishing tools

134 General Information

137 Polishing points, group P1

140 Polishing points, group P2

144 Felt polishing points, group P3

148 Grinding- and diamond pastes,
sprays and thinners

151 Flexible polishing sticks, group P4

153 Polishing points, group P5

155 Polishing points and wheels,
marbling points, group P6

161 Small polishing points, group P7

381 Power tools

Product line marking

Product lines are labelled in the table header with the appropriate tabs. Further information on page **14** and **15**.

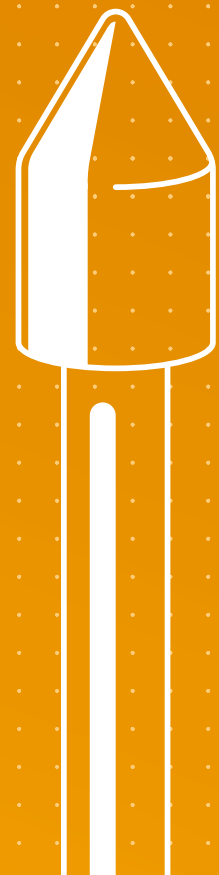

General Information

Should you wish to enhance your product with the desired optical polish or where a defined technical surface finish value must be achieved, there are many good reasons why LUKAS polishing tools can be used on your particular workpiece. Current examples of applications where the highest precision and tolerances must be achieved can be found in the car industry, pump and turbine manufacture and the aerospace industry. Polished surfaces guarantee hygienic and clean working conditions in the food and pharmaceutical industries. The tool and mould manufacturers polish surfaces to a mirror finish in order to achieve a precise replication of the profile to the finished product.

Due to the ever increasing demand for high precision, LUKAS have developed a wide range of polishing tools using different raw materials in various grit sizes and hardnesses.

LUKAS polishing tools are divided into groups – P1 to P7 – to suit specific applications. These tools include polishing wheels, points and sticks to cover a wide variety of applications.

On the following page, you will find an illustration giving a general overview of such applications.

Safety instructions

LUKAS polishing points under groups P1 and P5 are manufactured according to EN 12413 and are allowed to run at max. 50m/s. However, group P2 is only allowed max. 16m/s. The permissible peripheral speed of the product group P6 depends upon the hardness grade which in the case of MWP is max. 20m/s. The optimal working speed however generally lies below the maximum allowed; this reduces the heat generated and increases tool life. LUKAS polishing mounted points are supplied with a safety ticket which stipulates maximum R.P.M. for different shaft overhang lengths.

For the safe use of polishing points and wheels, please take note of the following operating instructions:

- FEPA safety recommendations for the correct use of abrasive products
- FEPA safety instructions for bonded abrasives

Application example of P2





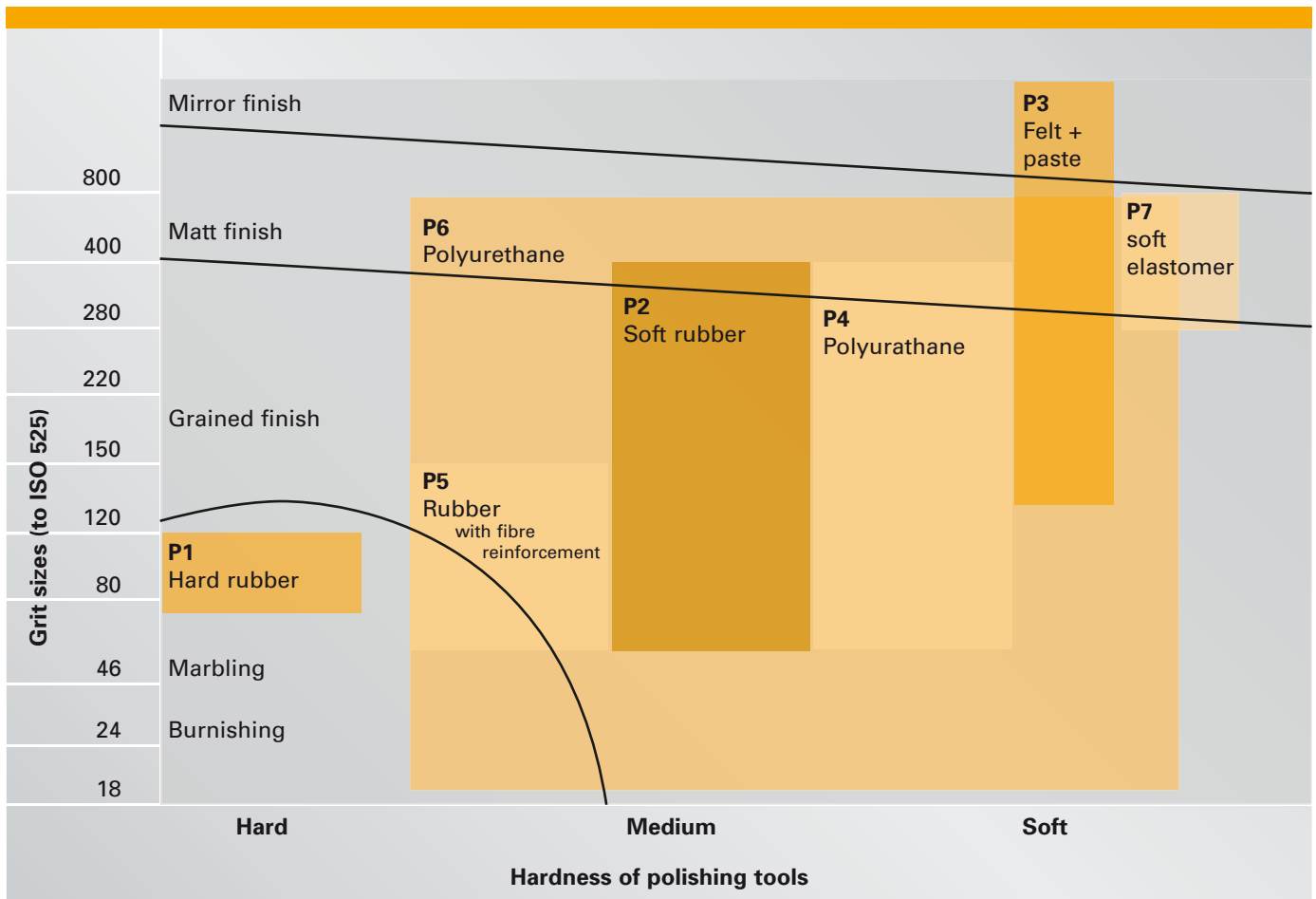



Areas of application

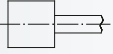
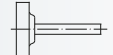
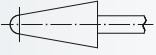

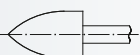
P1	polishing points consist of a hard rubber bonding with a grit size 100. They are suited for fine finishing applications and for the preparation of surfaces which require further polishing operations
P2	polishig points and wheels are manufactured using a soft rubber bond in grit sizes 46 to 280. Grained and matt finishes on small surface areas can be produced; to achieve the required result, different grit sizes used in sequence should be applied.
P3	felt polishing tools are used in conjunction with a SIC or diamong polishing paste to give the best results even up to a mirror finish.
P4	polishing sticks are manufactured from polyurethane (PU). Areas of application and the results are similar to those detailed in group P2. Polishing sticks are used manually.
P5	polishing points contain a fibre reinforcement to increase tool life. Achievable surface finish lies between group P1 and P2.
P6	polishing tools are available in various forms – mounted points, marbling points, rolls for satin finishes and polishing wheels. The hardness of the polyurethane bonding (PU) can be divided into 4 categories – from soft to hard. Available grit sizes in SIC 24 to 400. These tools give the opportunity of a much wider field of application including larger surfaces. The main application is on stationary polishing machines e.g. centerless polishing of tubes.
P7	polishing mounted points with shaft diameter 2,35 mm using SIC grain in sizes 240 or 400 in a silicon bond. These small tools are very soft and are exceptionally suited for the polishing of jewellery and other small parts.

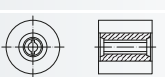
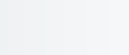
A summary of available shapes

Shape	Type	Shape (Lukas)	Available product range
	Cylindrical, Typ 1	ZY	P1, P2, P3, P5, P6
	Cylindrical, Typ 2	ZY2	P1, P2
	Spherical	KE	P1, P2, P3
	Conical	KU	P1, P2, P3, P5
	Arch pointed nose	SP	P2, P3, P5
	Cylindrical round nose	WR	P1, P2
	Wheel	SE1	P3, P6
	Roll	PW	P6
	Stick	SF, SR, SV	P4
	Disc	R	P7
	Lense	L	P7

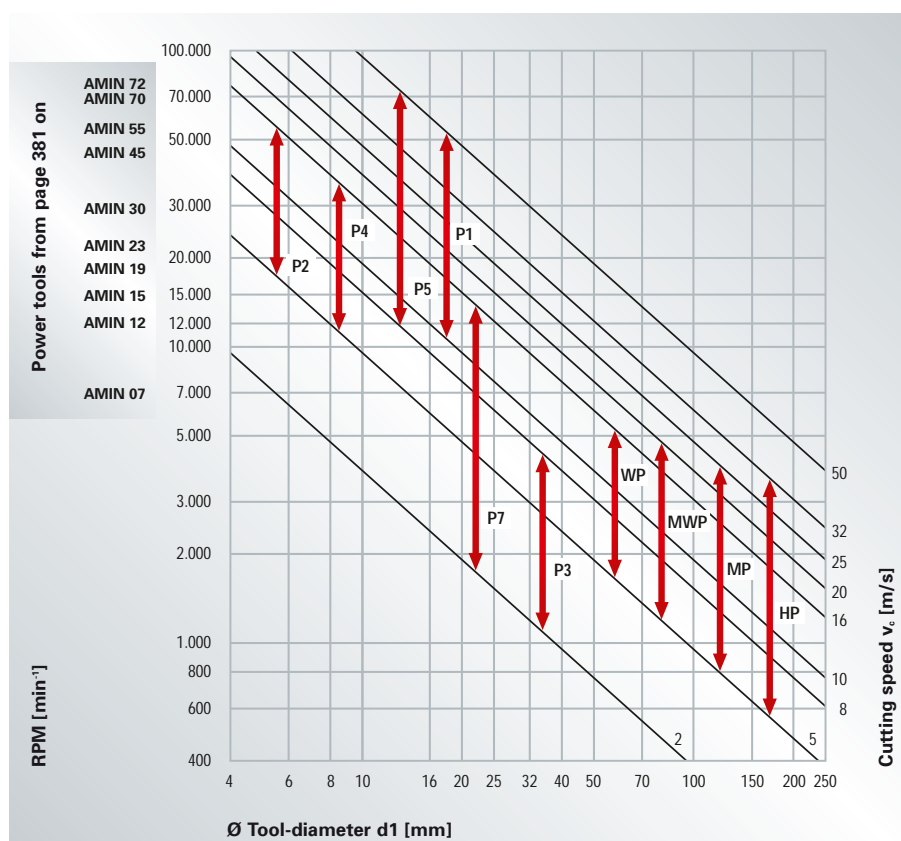

Quality and application P1

These polishing points are available in one grit combination only. The surface finish is similar to a finish with grit size 100. The hard-rubber bond makes these points particularly suitable for finishing castings, hard and soft tool steels and also alloyed steel. There is



no loading with these points. If applied with low pressure, they have a long and economical tool life.



Industry

Shape ZY, Cylindrical (according to DIN 69170)

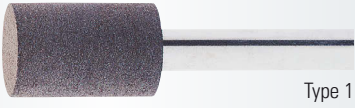
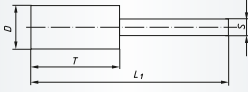
Ordering example: A2600004083

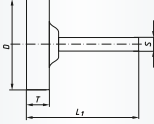
 <p>Type 1</p>		<p>Packing unit: Shank 3 mm = 20 pcs. per type, Shank 6 mm = 10 pcs. per type Further dimensions on request v_{max}: 50 m/s</p>
 <p>Type 2</p>		

Description	Type	D mm	T mm	S mm	L ₁ mm	Product-Number	recommended for								
P1ZY 0408.03	1	4	8	3	38	A2600004083	1	2	3	4	5	7			■
P1ZY 0510.03	1	5	10	3	40	A2600005103	1	2	3	4	5	7			■
P1ZY 0610.03	1	6	10	3	40	A2600006103	1	2	3	4	5	7			■
P1ZY 0710.03	1	7	10	3	40	A2600007103	1	2	3	4	5	7			■
P1ZY 0810.03	1	8	10	3	40	A2600008103	1	2	3	4	5	7			■
P1ZY 0816.06	1	8	16	6	56	A2600008166	1	2	3	4	5	7			■
P1ZY 0820.06	1	8	20	6	60	A2600008206	1	2	3	4	5	7			■
P1ZY 1010.03	1	10	10	3	40	A2600010103	1	2	3	4	5	7			■
P1ZY 1013.03	1	10	13	3	43	A2600010133	1	2	3	4	5	7			■
P1ZY 1016.03	1	10	16	3	46	A2600010163	1	2	3	4	5	7			■
P1ZY 1020.06	1	10	20	6	60	A2600010206	1	2	3	4	5	7			■
P1ZY 1303.03	2	13	3	3	33	A2607013033	1	2	3	4	5	7			■
P1ZY 1313.03	1	13	13	3	43	A2600013133	1	2	3	4	5	7			■
P1ZY 1316.03	1	13	16	3	46	A2600013163	1	2	3	4	5	7			■
P1ZY 1320.06	1	13	20	6	60	A2600013206	1	2	3	4	5	7			■
P1ZY 1604.03	2	16	4	3	34	A2607016043	1	2	3	4	5	7			■
P1ZY 1616.03	1	16	16	3	46	A2600016163	1	2	3	4	5	7			■
P1ZY 1620.06	1	16	20	6	60	A2600016206	1	2	3	4	5	7			■
P1ZY 1632.06	1	16	32	6	72	A2600016326	1	2	3	4	5	7			■
P1ZY 2006.03	2	20	6	3	36	A2607020063	1	2	3	4	5	7			■
P1ZY 2020.06	1	20	20	6	60	A2600020206	1	2	3	4	5	7			■
P1ZY 2032.06	1	20	32	6	72	A2600020326	1	2	3	4	5	7			■
P1ZY 3210.06	2	32	10	6	50	A2607032106	1	2	3	4	5	7			■
P1ZY 3216.06	1	32	16	6	56	A2600032166	1	2	3	4	5	7			■
P1ZY 4020.06	1	40	20	6	60	A2600040206	1	2	3	4	5	7			■



Industry

Shape KS, conical pointed nose (according to DIN 69170)

Ordering example: A2602016326

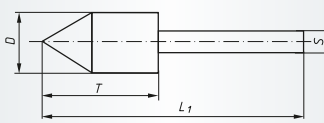

Packing unit:

10 pcs. per type
Further dimensions on request
 $v_{max.}$: 50 m/s

Description	D mm	T mm	S mm	L ₁ mm	Product-Number	recommended for
P1KS 1632.06	16	32	6	72	A2602016326	1 2 3 4 5 7



Industry

Shape KU, Spherical (according to DIN 69170)

Ordering example: A2605008083

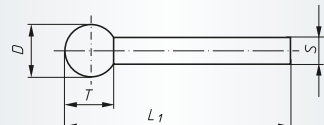
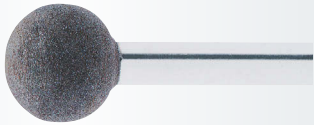

Packing unit:

Shank 3 mm = 20 pcs. per type,
Shank 6 mm = 10 pcs. per type
Further dimensions on request
 $v_{max.}$: 50 m/s

Description	D mm	T mm	S mm	L ₁ mm	Product-Number	recommended for
P1KU 0808.03	8	8	3	38	A2605008083	1 2 3 4 5 7
P1KU 1616.06	16	16	6	55	A2605016166	1 2 3 4 5 7



Industry

Shape WR, Cylindrical round nose (according to DIN 69170)

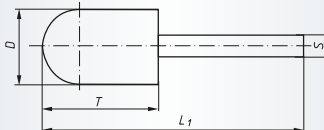

Packing unit:

10 pcs. per type
 $v_{max.}$: 50 m/s

available on request



Industry

Shape KE, Conical round nose (according to DIN 69170)

Ordering example: A2609020326

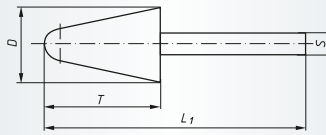

Packing unit:
10 pcs. per type
Further dimensions on request
 $v_{max.}$: 50 m/s

Description	D mm	T mm	S mm	L ₁ mm	Product-Number	recommended for	
P1KE 2032.06	20	32	6	72	A2609020326	1 2 3 4 5 7	■



Industry

Assortment, Polishing points, 114

Ordering example: A2600114



Packing unit:
1 pc. per type
Further dimensions on request
 $v_{max.}$: 50 m/s

Description	Contents	1 piece each	Product-Number	recommended for	
Assortment 114	14-pieces	P1ZY 0408.03; P1ZY 0510.03; P1ZY 0610.03; P1ZY 0710.03; P1ZY 0810.03; P1ZY 1010.03; P1ZY 1013.03; P1ZY 1016.03; P1ZY 1303.03; P1ZY 1313.03; P1ZY 1316.03; P1ZY 1604.03; P1ZY 1616.03; P1ZY 2006.03	A2600114	1 2 3 4 5 7	■

Specification and application P2

The polishing mounted points of this group are available in the five grit sizes as detailed below, and are available in a variety of shapes and sizes. They are colour coded to prevent any confusion and to avoid any errors in the polishing process. The soft rubber bonding allows for a very soft grinding effect. Polishing points of this group P2 are mainly used on a pre-machined surface where a fine

polished finish is required. Polishing wheels in this group are also available with a max. diameter 200mm. Exact dimensions and prices are available on request.



					
Color	black	pale grey	red	brown	green
Grit size	46	80	120	220	280



Industry

Shape ZY, Cylindrical (according to DIN 69170)

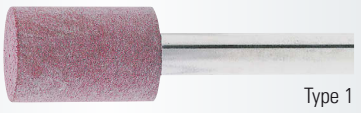
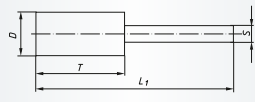
Ordering example: A2610004083080

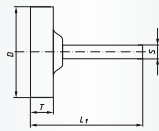
	Type 1		Packing unit: Shank 3 mm = 20 pcs. per type, Shank 6 mm = 10 pcs. per type Further dimensions and grit sizes on request $v_{max.}: 16 \text{ m/s}$
	Type 2		

Description	Grit	Type	D mm	T mm	S mm	L ₁ mm	Product-Number	recommended for
P2ZY 0408.03	80	1	4	8	3	38	A2610004083080	1 2 3 4 5 6 7 8
P2ZY 0408.03	120	1	4	8	3	38	A2610004083120	1 2 3 4 5 6 7 8
P2ZY 0408.03	220	1	4	8	3	38	A2610004083220	1 2 3 4 5 6 7 8
P2ZY 0408.03	280	1	4	8	3	38	A2610004083280	1 2 3 4 5 6 7 8
P2ZY 0510.03	80	1	5	10	3	40	A2610005103080	1 2 3 4 5 6 7 8
P2ZY 0510.03	120	1	5	10	3	40	A2610005103120	1 2 3 4 5 6 7 8
P2ZY 0510.03	220	1	5	10	3	40	A2610005103220	1 2 3 4 5 6 7 8
P2ZY 0510.03	280	1	5	10	3	40	A2610005103280	1 2 3 4 5 6 7 8
P2ZY 0610.03	80	1	6	10	3	40	A2610006103080	1 2 3 4 5 6 7 8
P2ZY 0610.03	120	1	6	10	3	40	A2610006103120	1 2 3 4 5 6 7 8
P2ZY 0610.03	220	1	6	10	3	40	A2610006103220	1 2 3 4 5 6 7 8
P2ZY 0610.03	280	1	6	10	3	40	A2610006103280	1 2 3 4 5 6 7 8
P2ZY 0810.03	46	1	8	10	3	40	A2610008103046	1 2 3 4 5 6 7 8



Industry

Shape ZY, Cylindrical (according to DIN 69170)

Ordering example: A2610008103080

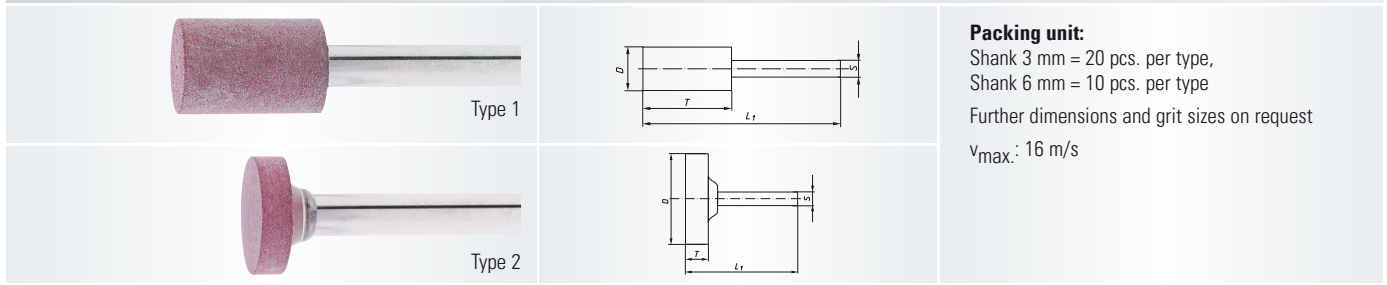

Packing unit:

Shank 3 mm = 20 pcs. per type,
Shank 6 mm = 10 pcs. per type

Further dimensions and grit sizes on request

v_{max.}: 16 m/s

Description	Grit	Type	D mm	T mm	S mm	L ₁ mm	Product-Number	recommended for	
P2ZY 0810.03	80	1	8	10	3	40	A2610008103080	1 2 3 4 5 6 7 8	■
P2ZY 0810.03	120	1	8	10	3	40	A2610008103120	1 2 3 4 5 6 7 8	■
P2ZY 0810.03	220	1	8	10	3	40	A2610008103220	1 2 3 4 5 6 7 8	■
P2ZY 0810.03	280	1	8	10	3	40	A2610008103280	1 2 3 4 5 6 7 8	■
P2ZY 0816.06	80	1	8	16	6	56	A2610008166080	1 2 3 4 5 6 7 8	■
P2ZY 0816.06	120	1	8	16	6	56	A2610008166120	1 2 3 4 5 6 7 8	■
P2ZY 0816.06	220	1	8	16	6	56	A2610008166220	1 2 3 4 5 6 7 8	■
P2ZY 0816.06	280	1	8	16	6	56	A2610008166280	1 2 3 4 5 6 7 8	■
P2ZY 1010.03	46	1	10	10	3	40	A2610010103046	1 2 3 4 5 6 7 8	■
P2ZY 1010.03	80	1	10	10	3	40	A2610010103080	1 2 3 4 5 6 7 8	■
P2ZY 1010.03	120	1	10	10	3	40	A2610010103120	1 2 3 4 5 6 7 8	■
P2ZY 1010.03	220	1	10	10	3	40	A2610010103220	1 2 3 4 5 6 7 8	■
P2ZY 1010.03	280	1	10	10	3	40	A2610010103280	1 2 3 4 5 6 7 8	■
P2ZY 1020.06	80	1	10	20	6	60	A2610010206080	1 2 3 4 5 6 7 8	■
P2ZY 1020.06	120	1	10	20	6	60	A2610010206120	1 2 3 4 5 6 7 8	■
P2ZY 1020.06	220	1	10	20	6	60	A2610010206220	1 2 3 4 5 6 7 8	■
P2ZY 1020.06	280	1	10	20	6	60	A2610010206280	1 2 3 4 5 6 7 8	■
P2ZY 1313.03	80	1	13	13	3	43	A2610013133080	1 2 3 4 5 6 7 8	■
P2ZY 1313.03	120	1	13	13	3	43	A2610013133120	1 2 3 4 5 6 7 8	■
P2ZY 1313.03	220	1	13	13	3	43	A2610013133220	1 2 3 4 5 6 7 8	■
P2ZY 1313.03	280	1	13	13	3	43	A2610013133280	1 2 3 4 5 6 7 8	■
P2ZY 1316.03	120	1	13	16	3	46	A2610013163120	1 2 3 4 5 6 7 8	■
P2ZY 1320.06	46	1	13	20	6	60	A2610013206046	1 2 3 4 5 6 7 8	■
P2ZY 1320.06	80	1	13	20	6	60	A2610013206080	1 2 3 4 5 6 7 8	■
P2ZY 1320.06	120	1	13	20	6	60	A2610013206120	1 2 3 4 5 6 7 8	■
P2ZY 1320.06	220	1	13	20	6	60	A2610013206220	1 2 3 4 5 6 7 8	■
P2ZY 1320.06	280	1	13	20	6	60	A2610013206280	1 2 3 4 5 6 7 8	■
P2ZY 1616.03	120	1	16	16	3	46	A2610016163120	1 2 3 4 5 6 7 8	■
P2ZY 1620.06	80	1	16	20	6	60	A2610016206080	1 2 3 4 5 6 7 8	■
P2ZY 1620.06	120	1	16	20	6	60	A2610016206120	1 2 3 4 5 6 7 8	■
P2ZY 1620.06	220	1	16	20	6	60	A2610016206220	1 2 3 4 5 6 7 8	■
P2ZY 1620.06	280	1	16	20	6	60	A2610016206280	1 2 3 4 5 6 7 8	■
P2ZY 1632.06	80	1	16	32	6	72	A2610016326080	1 2 3 4 5 6 7 8	■
P2ZY 1632.06	120	1	16	32	6	72	A2610016326120	1 2 3 4 5 6 7 8	■
P2ZY 1632.06	220	1	16	32	6	72	A2610016326220	1 2 3 4 5 6 7 8	■
P2ZY 2020.06	46	1	20	20	6	60	A2610020206046	1 2 3 4 5 6 7 8	■
P2ZY 2020.06	80	1	20	20	6	60	A2610020206080	1 2 3 4 5 6 7 8	■
P2ZY 2020.06	120	1	20	20	6	60	A2610020206120	1 2 3 4 5 6 7 8	■
P2ZY 2020.06	220	1	20	20	6	60	A2610020206220	1 2 3 4 5 6 7 8	■

142 Polishing points, group P2



Industry

Shape ZY, Cylindrical (according to DIN 69170)

Ordering example: A2610020206280

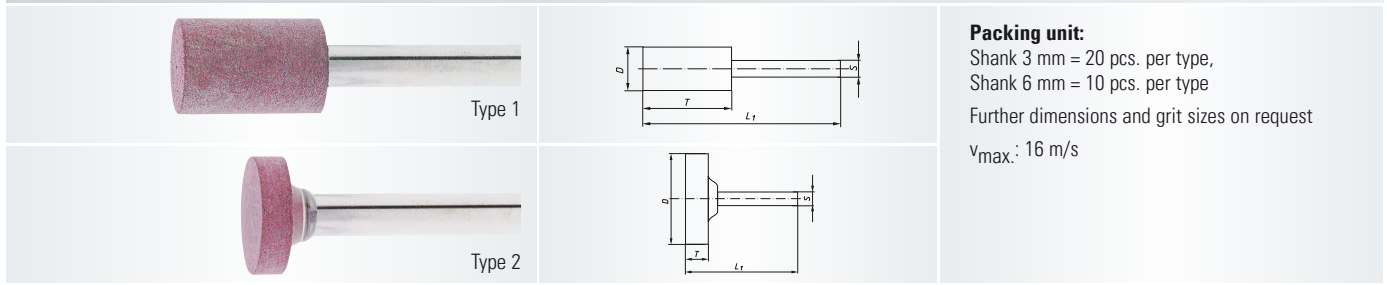

Packing unit:

Shank 3 mm = 20 pcs. per type,
Shank 6 mm = 10 pcs. per type

Further dimensions and grit sizes on request

$v_{max.}$: 16 m/s

Description	Grit	Type	D mm	T mm	S mm	L ₁ mm	Product-Number	recommended for	
P2ZY 2020.06	280	1	20	20	6	60	A2610020206280	1 2 3 4 5 6 7 8	■
P2ZY 2032.06	80	1	20	32	6	72	A2610020326080	1 2 3 4 5 6 7 8	■
P2ZY 2032.06	120	1	20	32	6	72	A2610020326120	1 2 3 4 5 6 7 8	■
P2ZY 2032.06	220	1	20	32	6	72	A2610020326220	1 2 3 4 5 6 7 8	■
P2ZY 2032.06	280	1	20	32	6	72	A2610020326280	1 2 3 4 5 6 7 8	■
P2ZY 2510.06	120	2	25	10	6	50	A2617025106120	1 2 3 4 5 6 7 8	■
P2ZY 3210.06	120	2	32	10	6	50	A2617032106120	1 2 3 4 5 6 7 8	■
P2ZY 3210.06	220	2	32	10	6	50	A2617032106220	1 2 3 4 5 6 7 8	■
P2ZY 3220.06	120	1	32	20	6	60	A2610032206120	1 2 3 4 5 6 7 8	■
P2ZY 3232.06	120	1	32	32	6	72	A2610032326120	1 2 3 4 5 6 7 8	■
P2ZY 3232.06	280	1	32	32	6	72	A2610032326280	1 2 3 4 5 6 7 8	■
P2ZY 4010.06	120	2	40	10	6	50	A2617040106120	1 2 3 4 5 6 7 8	■
P2ZY 4020.06	46	1	40	20	6	60	A2610040206046	1 2 3 4 5 6 7 8	■
P2ZY 4020.06	120	1	40	20	6	60	A2610040206120	1 2 3 4 5 6 7 8	■



Industry

Shape SP, Arch pointed nose (according to DIN 69170)

Ordering example: A2611013206120

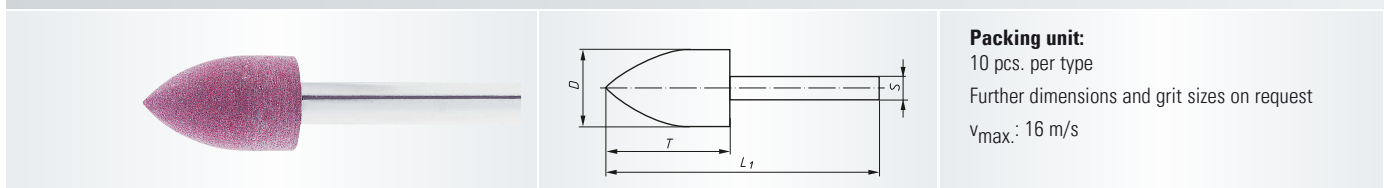

Packing unit:

10 pcs. per type

Further dimensions and grit sizes on request

$v_{max.}$: 16 m/s

Description	Grit	D mm	T mm	S mm	L ₁ mm	Product-Number	recommended for	
P2SP 1320.06	120	13	20	6	60	A2611013206120	1 2 3 4 5 6 7 8	■
P2SP 2032.06	220	20	32	6	72	A2611020326220	1 2 3 4 5 6 7 8	■



Industry

Shape KU, Spherical (according to DIN 69170)

Ordering example: A2615008083120

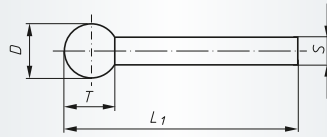
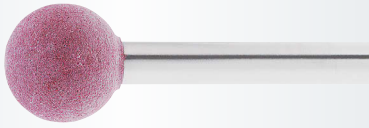

Packing unit:

Shank 3 mm = 20 pcs. per type,
Shank 6 mm = 10 pcs. per type

Further dimensions and grit sizes on request

v_{max} : 16 m/s

Description	Grit	D mm	T mm	S mm	L ₁ mm	Product-Number	recommended for	
P2KU 0808.03	120	8	8	3	38	A2615008083120	1 2 3 4 5 6 7 8	■
P2KU 1010.03	120	10	10	3	40	A2615010103120	1 2 3 4 5 6 7 8	■
P2KU 1616.06	120	16	16	6	56	A2615016166120	1 2 3 4 5 6 7 8	■
P2KU 1616.06	220	16	16	6	56	A2615016166220	1 2 3 4 5 6 7 8	■



Industry

Shape WR, Cylindrical round nose (according to DIN 69170)

Ordering example: A2618016326120

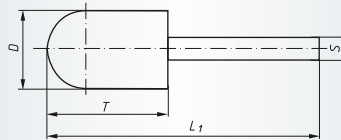

Packing unit:

10 pcs. per type

Further dimensions and grit sizes on request

v_{max} : 16 m/s

Description	Grit	D mm	T mm	S mm	L ₁ mm	Product-Number	recommended for	
P2WR 1632.06	120	16	32	6	72	A2618016326120	1 2 3 4 5 6 7 8	■



Industry

Shape KE, Conical round nose (according to DIN 69170)

Ordering example: A2619010206080

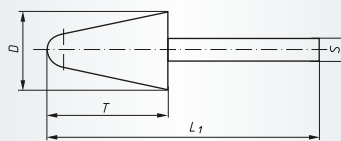

Packing unit:

10 pcs. per type

Further dimensions and grit sizes on request

v_{max} : 16 m/s

Description	Grit	D mm	T mm	S mm	L ₁ mm	Product-Number	recommended for	
P2KE 1020.06	80	10	20	6	60	A2619010206080	1 2 3 4 5 6 7 8	■
P2KE 1020.06	120	10	20	6	60	A2619010206120	1 2 3 4 5 6 7 8	■

Specification and application P3

LUKAS felt polishing points are available in two specifications:

- H3 as per DIN 61200
- H3S super hard and particularly effective when used in conjunction with diamond paste

The optimal peripheral speed for LUKAS felt polishing points is 2–8 m/s.

The LUKAS assortment of felt polishing tools reflects years of experience in this field and encompasses the most common shapes and sizes. Due to the extreme flexibility, felt polishing points together with LUKAS diamond paste are ideally suited for polishing exceptionally complex shapes e.g. pressure and injection moulds, drawing- press- and cutting tools, dies, bearings, spindles, rolls, gauges etc.



Industry

Shape ZY, Cylindrical

Ordering example: A3700006103

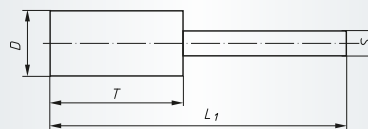
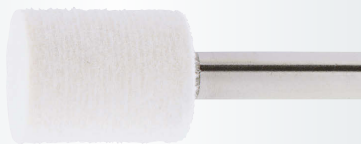

Packing unit:

Shank 3 mm = 20 pcs. per type,
Shank 6 mm = 10 pcs. per type
Further dimensions on request

Description	Quality	D mm	T mm	S mm	L ₁ mm	Product-Number	recommended for	
P3ZY 0610.03	H3	6	10	3	50	A3700006103	1 2 3 4 5 6 7 9	■
P3ZY 0610.03	H3-S	6	10	3	50	A37000061030001	1 2 3 4 5 6 7 9	■
P3ZY 0810.03	H3	8	10	3	50	A3700008103	1 2 3 4 5 6 7 9	■
P3ZY 0810.03	H3-S	8	10	3	50	A37000081030001	1 2 3 4 5 6 7 9	■
P3ZY 1012.03	H3	10	12	3	50	A3700010123	1 2 3 4 5 6 7 9	■
P3ZY 1012.03	H3-S	10	12	3	50	A37000101230001	1 2 3 4 5 6 7 9	■
P3ZY 1015.06	H3	10	15	6	55	A3700010156	1 2 3 4 5 6 7 9	■
P3ZY 1015.06	H3-S	10	15	6	55	A37000101560001	1 2 3 4 5 6 7 9	■
P3ZY 1215.03	H3	12	15	3	55	A3700012153	1 2 3 4 5 6 7 9	■
P3ZY 1215.03	H3-S	12	15	3	55	A37000121530001	1 2 3 4 5 6 7 9	■
P3ZY 1220.06	H3	12	20	6	60	A3700012206	1 2 3 4 5 6 7 9	■
P3ZY 1220.06	H3-S	12	20	6	60	A37000122060001	1 2 3 4 5 6 7 9	■
P3ZY 1620.06	H3	16	20	6	60	A3700016206	1 2 3 4 5 6 7 9	■
P3ZY 2025.06	H3	20	25	6	65	A3700020256	1 2 3 4 5 6 7 9	■
P3ZY 2025.06	H3-S	20	25	6	65	A37000202560001	1 2 3 4 5 6 7 9	■
P3ZY 2530.06	H3	25	30	6	70	A3700025306	1 2 3 4 5 6 7 9	■
P3ZY 3040.06	H3	30	40	6	80	A3700030406	1 2 3 4 5 6 7 9	■



Industry

Shape SP, Arch pointed nose

Ordering example: A3701006103

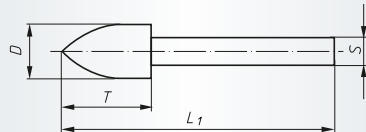

Packing unit:

Shank 3 mm = 20 pcs. per type,
Shank 6 mm = 10 pcs. per type
Further dimensions on request

Description	Quality	D mm	T mm	S mm	L ₁ mm	Product-Number	recommended for	
P3SP 0610.03	H3	6	10	3	50	A3701006103	1 2 3 4 5 6 7 9	■
P3SP 0810.03	H3	8	10	3	50	A3701008103	1 2 3 4 5 6 7 9	■
P3SP 1012.03	H3	10	12	3	52	A3701010123	1 2 3 4 5 6 7 9	■
P3SP 1015.06	H3	10	15	6	55	A3701010156	1 2 3 4 5 6 7 9	■
P3SP 1220.06	H3	12	20	6	60	A3701012206	1 2 3 4 5 6 7 9	■
P3SP 2025.06	H3	20	25	6	65	A3701020256	1 2 3 4 5 6 7 9	■
P3SP 2530.06	H3	25	30	6	70	A3701025306	1 2 3 4 5 6 7 9	■
P3SP 3040.06	H3	30	40	6	80	A3701030406	1 2 3 4 5 6 7 9	■



Industry

Shape KU, Spherical

Ordering example: A3703006063

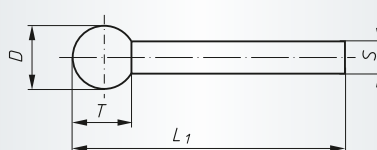
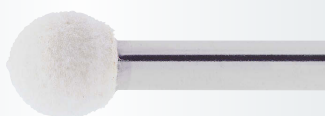

Packing unit:

Shank 3 mm = 20 pcs. per type,
Shank 6 mm = 10 pcs. per type
Further dimensions on request

Description	Quality	D mm	T mm	S mm	L ₁ mm	Product-Number	recommended for	
P3KU 0605.03	H3	6	5,5	3	45	A3703006063	1 2 3 4 5 6 7 9	■
P3KU 0807.03	H3	8	7,5	3	50	A3703008083	1 2 3 4 5 6 7 9	■
P3KU 1009.03	H3	10	9	3	50	A3703010103	1 2 3 4 5 6 7 9	■
P3KU 1009.06	H3	10	9	6	50	A3703010106	1 2 3 4 5 6 7 9	■
P3KU 1211.06	H3	12	11	6	50	A3703012126	1 2 3 4 5 6 7 9	■
P3KU 2019.06	H3	20	19	6	60	A3703020206	1 2 3 4 5 6 7 9	■

146 Felt polishing points, group P3



Industry

Shape KE, Conical round nose

Ordering example: A3705010123

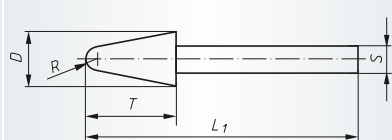

Packing unit:

Shank 3 mm = 20 pcs. per type,
Shank 6 mm = 10 pcs. per type

Further dimensions on request

Description	Quality	D mm	T mm	S mm	L ₁ mm	R mm	Product-Number	recommended for	
P3KE 1012.03	H3	10	12	3	50	2,5	A3705010123	1 2 3 4 5 6 7 9	■
P3KE 1015.06	H3	10	15	6	55	2,5	A3705010156	1 2 3 4 5 6 7 9	■
P3KE 1015.06	H3-S	10	15	6	55	2,5	A37050101560001	1 2 3 4 5 6 7 9	■
P3KE 1620.06	H3	16	20	6	60	3	A3705016206	1 2 3 4 5 6 7 9	■
P3KE 2025.06	H3	20	25	6	65	3,5	A3705020256	1 2 3 4 5 6 7 9	■
P3KE 2530.06	H3	25	30	6	70	4,5	A3705025306	1 2 3 4 5 6 7 9	■
P3KE 3040.06	H3	30	40	6	80	6,5	A3705030406	1 2 3 4 5 6 7 9	■

Application example P3





Industry

Shape S1, Wheels

Ordering example: A3750040106

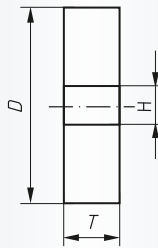

Packing unit:
10 pcs. per type
Further dimensions on request

Description	Quality	D mm	T mm	H mm	Product-Number	recommended for	
P3S1 4010.06	H3	40	10	6	A3750040106	1 2 3 4 5 6 7 9	■
P3S1 5010.06	H3	50	10	6	A3750050106	1 2 3 4 5 6 7 9	■
P3S1 5020.06	H3	50	20	6	A3750050206	1 2 3 4 5 6 7 9	■
P3S1 6010.06	H3	60	10	6	A3750060106	1 2 3 4 5 6 7 9	■
P3S1 6020.06	H3	60	20	6	A3750060206	1 2 3 4 5 6 7 9	■



Industry

Arbors for felt polishing wheels

Ordering example: A1630780

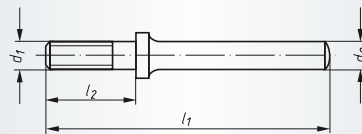
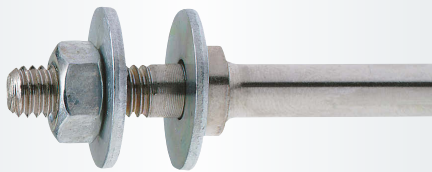

Packing unit:
5 pcs. per type
The delivery includes for each stud
• 2 washers Ø 18 mm
• 2 washers Ø 30 mm
• 1 hex nut

Description	d ₁ mm	l ₂ mm	d ₂ mm	l ₁ mm	n max. (1/min)	Product-Number	
ASB 780	M6	20	6	63	7.000	A1630780	■
ASB 781	M6	30	6	73	7.000	A1630781	■

Specification and application of diamond paste

Type	Quality	Recommended applications
Super-M	oil/alcohol soluble, medium concentration, HP diamond grit	for the occasional use as first and second polishing stages on hard materials
Super-W	oil/alcohol soluble, higher concentration, HP diamond grit	for the more frequent polishing operations on hard materials – from the second polishing stage
Super-F	oil/alcohol soluble, high concentration, HP diamond grit, high percentage of the same mesh size	for regular polishing on hard materials – where a reduction in the polishing cycle time is required – on extremely hard surface coatings – from the second polishing stage

List of grit sizes

Grit Size	Application	Tool material	Cutting speed
30 μ 23 μ 15 μ	Fine polish	Steel, cast iron, bronze, brass, copper, safety glass, laminated wood, plywood	v = 1–3 m/s
9 μ	Pre-polish	Cast iron, bronze, brass, copper, safety glass, laminated wood, plywood, hardwood	v = 1–3 m/s
6 μ 3 μ 1 μ 0,25 μ	Mirror polish	Soft wood, felt (hard or soft), paper, cotton wool	v = 5–20 m/s

Examples of diamond pastes and diamond sprays





Industry

Grinding compound

Ordering example: A3760120



Packing unit:
1 pc. per type
Contents: 250 g

Description	Quality	Grit	µm	Product-Number	recommended for	
SP-1	medium	120	88 – 125	A3760120	1 2 3 4 5 6 7	■
SP-2	fine	180	55 – 88	A3760180	1 2 3 4 5 6 7	■
SP-3	very fine	320	20 – 40	A3760320	1 2 3 4 5 6 7	■

Ingredient: silicon carbide paste, oil-soluble, can be used with thinners, cleaned with oil, spirit or petrol.

Application: For polishing pre-ground surfaces; particularly suited for hard metallic surfaces e.g. steel, iron, cast iron, bronze, brass and copper



Industry

Diamond pastes

Ordering example: A34105062



Packing unit:
1 pc. per type
Contents: 5 g

Description	Quality	Grit µ	Color of paste	Product-Number	recommended for	
M-062	Super-M	3	green	A34105062	1 2 3 4 5 6 7 9	■
M-063	Super-M	6	yellow	A34105063	1 2 3 4 5 6 7 9	■
M-064	Super-M	9	red	A34105064	1 2 3 4 5 6 7 9	■
M-065	Super-M	15	pale brown	A34105065	1 2 3 4 5 6 7 9	■
M-066	Super-M	30	dark brown	A34105066	1 2 3 4 5 6 7 9	■
W-082	Super-W	3	green	A34103082	1 2 3 4 5 6 7 9	■
W-083	Super-W	6	yellow	A34103083	1 2 3 4 5 6 7 9	■
W-084	Super-W	9	red	A34103084	1 2 3 4 5 6 7 9	■
W-085	Super-W	15	pale brown	A34103085	1 2 3 4 5 6 7 9	■
F-091	Super-F	1	blau	A34101091	1 2 3 4 5 6 7 9	■
F-092	Super-F	3	green	A34101092	1 2 3 4 5 6 7 9	■
F-093	Super-F	6	yellow	A34101093	1 2 3 4 5 6 7 9	■
F-094	Super-F	9	red	A34101094	1 2 3 4 5 6 7 9	■
F-095	Super-F	15	pale brown	A34101095	1 2 3 4 5 6 7 9	■

150 Diamond sprays and thinner



Industry

Diamond sprays

Ordering example: A34104070



Packing unit:
1 pc. per type
Contents: 150 ml = 126 g

Description	Grit μ	Color	Product-Number	recommended for	
GS-070	0,25	pale grey	A34104070	1 2 3 4 5 6 7 9	■
GS-071	1	blue	A34104071	1 2 3 4 5 6 7 9	■
GS-072	3	green	A34104072	1 2 3 4 5 6 7 9	■
GS-073	6	yellow	A34104073	1 2 3 4 5 6 7 9	■
GS-074	9	red	A34104074	1 2 3 4 5 6 7 9	■



Industry

Thinner

Ordering example: A341063003



Packing unit:
1 pc. per type
Contents: 100 ml

Description	Color	Product-Number	recommended for	
MWF 3003	green	A341063003	1 2 3 4 5 6 7 9	■

Specification and application P4

Tools within this group are bonded with polyurethane (PU) and are manufactured in various hardnesses. They contain a mixture of abrasive grain (aluminium oxide, silicon carbide) and fillers. To optically differentiate between qualities, these tools are colour coded. Products in this group have a relatively dense structure.

Pores resulting from the manufacturing process are of no detriment. A range of flexibility from soft to hard relating to the cross section are available. These polishing sticks are mainly used manually for mould manufacture.

Color	Qualities	Color	Qualities	Color	Qualities
pale grey	SIC 80 soft	pale green	SIC 240 soft	pale red	EKW 150 soft
grey	SIC 80 hard	green	SIC 240 hard	red	EKW 150 hard
pale blue	SIC 150 soft	beige	EKW 80 soft	pale brown	EKW 240 soft
blue	SIC 150 hard	dark beige	EKW 80 hard	brown	EKW 240 hard



Industry

Polishing sticks, flat

Ordering example: P4SF 0612.070 SIC 80 soft

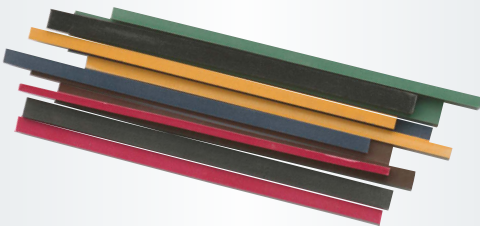

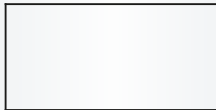

Packing unit:
10 pcs. per type
Further dimensions on request
All items are available within a few days ex-intermediate stock.

Description	H mm	B mm	L mm			recommended for							▲			
						1	2	3	4	5	6	7				
P4SF 0612.070	6	12	70			1	2	3	4	5	6	7				▲
P4SF 0612.140	6	12	140			1	2	3	4	5	6	7				▲
P4SF 0816.070	8	16	70			1	2	3	4	5	6	7				▲
P4SF 0816.140	8	16	140			1	2	3	4	5	6	7				▲
P4SF 0816.210	8	16	210			1	2	3	4	5	6	7				▲
P4SF 1020.070	10	20	70			1	2	3	4	5	6	7				▲
P4SF 1020.140	10	20	140			1	2	3	4	5	6	7				▲
P4SF 1020.210	10	20	210			1	2	3	4	5	6	7				▲
P4SF 1020.280	10	20	280			1	2	3	4	5	6	7				▲

152 Polishing sticks, group P4



Industry

Polishing sticks, round

Ordering example: P4SR 0006.070 EKW 80 hard

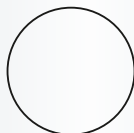
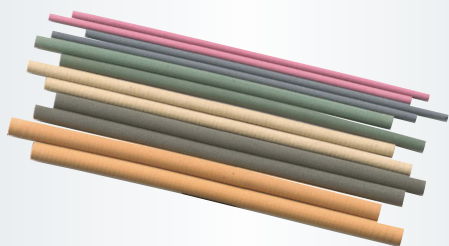

Packing unit:

10 pcs. per type

Further dimensions on request

All items are available within a few days ex-intermediate stock.

Description	Ø mm	L mm				recommended for	
P4SR 0006.070	6	70				1 2 3 4 5 6 7	▲
P4SR 0006.140	6	140				1 2 3 4 5 6 7	▲
P4SR 0010.070	10	70				1 2 3 4 5 6 7	▲
P4SR 0010.140	10	140				1 2 3 4 5 6 7	▲
P4SR 0010.210	10	210				1 2 3 4 5 6 7	▲
P4SR 0012.070	12	70				1 2 3 4 5 6 7	▲
P4SR 0012.140	12	140				1 2 3 4 5 6 7	▲
P4SR 0012.210	12	210				1 2 3 4 5 6 7	▲
P4SR 0012.280	12	280				1 2 3 4 5 6 7	▲
P4SR 0015.070	15	70				1 2 3 4 5 6 7	▲
P4SR 0015.140	15	140				1 2 3 4 5 6 7	▲
P4SR 0015.210	15	210				1 2 3 4 5 6 7	▲
P4SR 0015.280	15	280				1 2 3 4 5 6 7	▲



Industry

Polishing sticks, square

Ordering example: P4SV 0606.070 SIC 80 hard

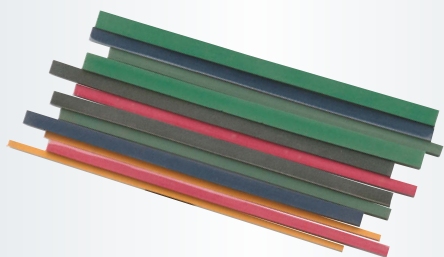

Packing unit:

10 pcs. per type

Further dimensions on request

All items are available within a few days ex-intermediate stock.

Description	H mm	B mm	L mm			recommended for	
P4SV 0606.070	6	6	70			1 2 3 4 5 6 7	▲
P4SV 0606.140	6	6	140			1 2 3 4 5 6 7	▲
P4SV 1010.070	10	10	70			1 2 3 4 5 6 7	▲
P4SV 1010.140	10	10	140			1 2 3 4 5 6 7	▲
P4SV 1010.210	10	10	210			1 2 3 4 5 6 7	▲
P4SV 1212.140	12	12	140			1 2 3 4 5 6 7	▲
P4SV 1212.210	12	12	210			1 2 3 4 5 6 7	▲
P4SV 1515.070	15	15	70			1 2 3 4 5 6 7	▲
P4SV 1515.140	15	15	140			1 2 3 4 5 6 7	▲
P4SV 1515.210	15	15	210			1 2 3 4 5 6 7	▲
P4SV 1515.280	15	15	280			1 2 3 4 5 6 7	▲

Specification and application P5

The polishing points of this group are characterized by their special structure and bonding i.e. fibre reinforced. This makes them ideally suited for fine finishing of aluminium and associated alloys, non-ferrous metals and low and high alloyed steels.

Due to the fibre reinforcement, these tools have exceptional edge-retention capabilities and resilience. Polishing points in group P5 are available in grit sizes detailed below; they are identified with a red marking.

			
Color	black	pale grey	red
Grit	46	80	120



Industry

Shape ZY, Cylindrical (according to DIN 69170)

Ordering example: A2620004083080

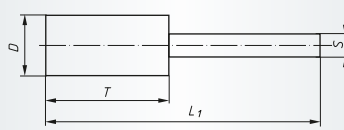

Packing unit:

Shank 3 mm = 20 pcs. per type,

Shank 6 mm = 10 pcs. per type

Further dimensions and grit sizes on request

v_{max} : 50 m/s

Description	Grit	D mm	T mm	S mm	L ₁ mm	Product-Number	recommended for	
P5ZY 0408.03	80	4	8	3	38	A2620004083080	1 2 3 4 5 6 7	■
P5ZY 0408.03	120	4	8	3	38	A2620004083120	1 2 3 4 5 6 7	■
P5ZY 0510.03	80	5	10	3	40	A2620005103080	1 2 3 4 5 6 7	■
P5ZY 0510.03	120	5	10	3	40	A2620005103120	1 2 3 4 5 6 7	■
P5ZY 0610.03	80	6	10	3	40	A2620006103080	1 2 3 4 5 6 7	■
P5ZY 0610.03	120	6	10	3	40	A2620006103120	1 2 3 4 5 6 7	■
P5ZY 0810.03	80	8	10	3	40	A2620008103080	1 2 3 4 5 6 7	■
P5ZY 0810.03	120	8	10	3	40	A2620008103120	1 2 3 4 5 6 7	■
P5ZY 0816.06	46	8	16	6	56	A2620008166046	1 2 3 4 5 6 7	■
P5ZY 0816.06	80	8	16	6	56	A2620008166080	1 2 3 4 5 6 7	■
P5ZY 0816.06	120	8	16	6	56	A2620008166120	1 2 3 4 5 6 7	■
P5ZY 1010.03	80	10	10	3	40	A2620010103080	1 2 3 4 5 6 7	■
P5ZY 1010.03	120	10	10	3	40	A2620010103120	1 2 3 4 5 6 7	■
P5ZY 1020.06	46	10	20	6	60	A2620010206046	1 2 3 4 5 6 7	■
P5ZY 1020.06	80	10	20	6	60	A2620010206080	1 2 3 4 5 6 7	■
P5ZY 1020.06	120	10	20	6	60	A2620010206120	1 2 3 4 5 6 7	■
P5ZY 1313.03	120	13	13	3	43	A2620013133120	1 2 3 4 5 6 7	■
P5ZY 1316.03	80	13	16	3	46	A2620013163080	1 2 3 4 5 6 7	■
P5ZY 1320.06	80	13	20	6	60	A2620013206080	1 2 3 4 5 6 7	■

154 Polishing points, group P5



Industry

Shape ZY, Cylindrical (according to DIN 69170)

Ordering example: A2620013206080

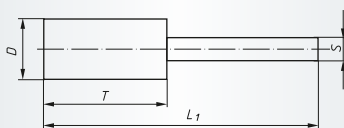

Packing unit:

Shank 3 mm = 20 pcs. per type,
Shank 6 mm = 10 pcs. per type

Further dimensions and grit sizes on request

$v_{max.}$: 50 m/s

Description	Grit	D mm	T mm	S mm	L ₁ mm	Product-Number	recommended for	
P5ZY 1320.06	120	13	20	6	60	A2620013206120	1 2 3 4 5 6 7	■
P5ZY 1620.06	80	16	20	6	60	A2620016206080	1 2 3 4 5 6 7	■
P5ZY 1620.06	120	16	20	6	60	A2620016206120	1 2 3 4 5 6 7	■
P5ZY 1632.06	46	16	32	6	72	A2620016326046	1 2 3 4 5 6 7	■
P5ZY 1632.06	80	16	32	6	72	A2620016326080	1 2 3 4 5 6 7	■
P5ZY 2020.06	80	20	20	6	60	A2620020206080	1 2 3 4 5 6 7	■
P5ZY 2032.06	46	20	32	6	72	A2620020326046	1 2 3 4 5 6 7	■
P5ZY 2032.06	120	20	32	6	72	A2620020326120	1 2 3 4 5 6 7	■
P5ZY 3232.06	80	32	32	6	72	A2620032326080	1 2 3 4 5 6 7	■
P5ZY 4016.06	120	40	16	6	56	A2620040166120	1 2 3 4 5 6 7	■



Industry

Shape SP, Arch pointed nose (according to DIN 69170)

Ordering example: A2621020326080

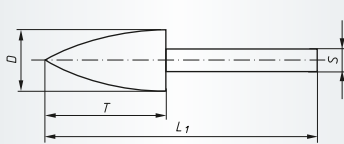

Packing unit:

10 pcs. per type

Further dimensions and grit sizes on request

$v_{max.}$: 50 m/s

Description	Grit	D mm	T mm	S mm	L ₁ mm	Product-Number	recommended for	
P5SP 2032.06	80	20	32	6	72	A2621020326080	1 2 3 4 5 6 7	■



Industry

Shape KU, Spherical (according to DIN 69170)

Ordering example: A2625008083080

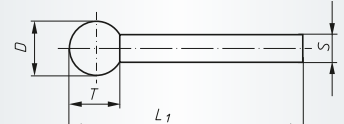

Packing unit:

20 pcs. per type

Further dimensions and grit sizes on request

$v_{max.}$: 50 m/s

Description	Grit	D mm	T mm	S mm	L ₁ mm	Product-Number	recommended for	
P5KU 0808.03	80	8	8	3	38	A2625008083080	1 2 3 4 5 6 7	■

Specification and application P6

Products in group P6 are manufactured with a polyurethane bond (PU) in different hardnesses.

These tools

- can be easily profiled
- quickly generate an excellent surface finish
- produce little heat during the polishing process
- do not load
- require no dressing
- contain no softener
- do not increase in hardness after long storage
- are ideal for both stationary and manual application

These polishing tools are used to improve surface finish and geometry. The main applications are the polishing and finishing of steel, brass, precious metals, sintered metals and plastic. The product range includes polishing points, marbling wheels, rolls for satin finishes, and wheels from 60 mm to 300 mm diameter. They can be used with or without coolant.

When wet polishing, the coolant must be maintained at a neutral (ph) value. For dressing, a dressing stick (page 124) or diamond dressing tool can be used.

Due to long tool life and a good edge retention, the tools are ideally suited for automated processes e.g. centerless polishing of tubes or marbling of high alloyed steel plates.

The following grades are available:

WP = soft, very flexible

MWP = medium to soft

MP = medium for general application

HP = hard, resilient for flat surfaces

SHP = super hard, for stationary applications

The bonding is mixed with silicon carbide „SIC“ or aluminium oxide „A“ grain in the FEPA grit sizes 24 to 400.

Application examples marbling points P6



Application recommendations polishing tools P6

	Removing rust, cleaning, tarnish removal	Cylindrical and surface grinding	Sharpening, dressing	Marbling, matt finishing		Deburring, cleaning up and rounding off				Burnishing				Pre-finishing				Polishing	
	MWP	SHP	SHP	WP	MWP	WP	MWP	MP	HP	WP	MWP	MP	HP	WP	MWP	MP	HP	WP	MWP
Gold, silver Nickel, aluminium Copper Brass																		400	400
														240	240				
												150		150					
												120	120						
						80			80	80		80							
					46	46				46		46							
Constructional steel	46																		
Stainless steel, titanium			400															400	400
			240												240	240			240
									150				150		150	150			
			120								120	120		120					
			80		80	80	80		80	80	80	80	80						
					46		46				46	46	46	46					
				24					24										
Hardened steel, Carbide		240															240		
		150											150						
		120											120						
		80					80												
							46												
Glass															400				
															240				
															150				
							80												
Rubber																		46	
Wood																		80	
Paint	46																		
Solder	240																		
Tin															80				
															46				

Grit sizes



Polishing Wheels, Form SE1

Ordering example: A29100600060041

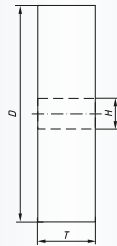
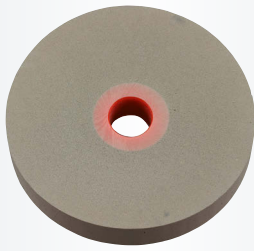

Packing unit:

1 pc. per type

Further dimensions and grit sizes on request

v_{max} : MWP = 20 m/s

WP = 16 m/s

SHP = 32 m/s

Description	Quality/ Grit	D mm	T mm	H mm	Product-Number	recommended for	
P6SE1 06006 B.06	SC 80 MWP	60	6	6	A29100600060041	1 2 3 4 5 6 7 9	■
P6SE1 06006 B.06	SC 150 MWP	60	6	6	A29100600060061	1 2 3 4 5 6 7 9	■
P6SE1 10010 B.25	SC 80 MWP	100	10	25	A29101000100041	1 2 3 4 5 6 7 9	■
P6SE1 10010 B.25	SC 150 MWP	100	10	25	A29101000100061	1 2 3 4 5 6 7 9	■
P6SE1 10020 B.25	SC 46 MWP	100	20	25	A29101000200021	1 2 3 4 5 6 7 9	■
P6SE1 10020 B.25	SC 80 MWP	100	20	25	A29101000200041	1 2 3 4 5 6 7 9	■
P6SE1 10020 B.25	SC 150 MWP	100	20	25	A29101000200061	1 2 3 4 5 6 7 9	■
P6SE1 10020 B.25	SC 400 MWP	100	20	25	A29101000200091	1 2 3 4 5 6 7 9	■
P6SE1 12510 B.25	SC 80 MWP	125	10	25	A29101250100041	1 2 3 4 5 6 7 9	■
P6SE1 12510 B.25	SC 150 MWP	125	10	25	A29101250100061	1 2 3 4 5 6 7 9	■
P6SE1 12520 B.25	SC 80 MWP	125	20	25	A29101250200041	1 2 3 4 5 6 7 9	■
P6SE1 12520 B.25	SC 150 MWP	125	20	25	A29101250200061	1 2 3 4 5 6 7 9	■
P6SE1 15010 B.25	SC 150 MWP	150	20	25	A29101500100061	1 2 3 4 5 6 7 9	■
P6SE1 15010 B.25	SC 150 SHP	150	10	25	A29101500100069	1 2 3 4 5 6 7 9	■
P6SE1 15015 B.20	SC 120 SHP	150	15	20	A29101500150059	1 2 3 4 5 6 7 9	■
P6SE1 15020 B.25	SC 80 MWP	150	20	25	A29101500200041	1 2 3 4 5 6 7 9	■
P6SE1 15020 B.25	SC 150 MWP	150	20	25	A29101500200061	1 2 3 4 5 6 7 9	■
P6SE1 15020 B.25	SC 80 WP	150	20	25	A29101500200040	1 2 3 4 5 6 7 9	■
P6SE1 15025 B.20	SC 46 MWP	150	25	20	A29101500250021	1 2 3 4 5 6 7 9	■
P6SE1 15025 B.25	SC 150 MWP	150	25	25	A29101500250061	1 2 3 4 5 6 7 9	■
P6SE1 15025 B.25	SC 80 WP	150	25	25	A29101500250040	1 2 3 4 5 6 7 9	■
P6SE1 17520 B.25	SC 80 MWP	175	20	25	A29101750200041	1 2 3 4 5 6 7 9	■
P6SE1 17520 B.25	SC 150 MWP	175	20	25	A29101750200061	1 2 3 4 5 6 7 9	■
P6SE1 20025 B.25	SC 80 MWP	200	25	25	A29102000250041	1 2 3 4 5 6 7 9	■
P6SE1 20025 B.25	SC 150 MWP	200	25	25	A29102000250061	1 2 3 4 5 6 7 9	■
P6SE1 20025 B.32	SC 46 MP	200	25	32	A29102000250024	1 2 3 4 5 6 7 9	■

These polishing wheels are supplied in a medium bond in the two grit sizes 80 and 150. Upon request these polishing wheels can also be delivered with the bonding HP (v_{max} 32 m/s) or MP (v_{max} 25 m/s).

Safety instructions:

Grinding and polishing wheels on stationary machines are to be used only from both sides with the appropriate flanges. The diameter of flange must be 2/3 of the wheel diameter. The flanges are provided with a recess (1–2 mm depth) up to 5–10 mm from the outer edge.

158 Mounting system for polishing wheels



Industry

Mounting system for polishing wheels

Ordering example: A6981008000

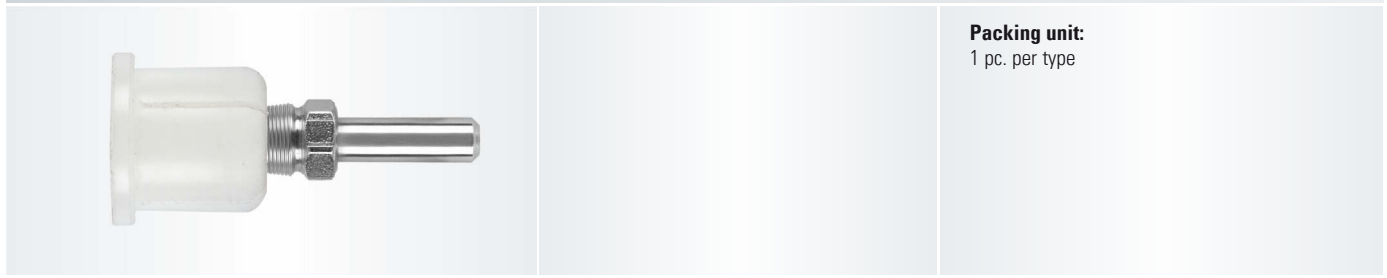

Packing unit:
1 pc. per type

Description	Product-Number		
Mounting system MCA + K25	A6981008000		■
<p>The mounting system for polishing wheels consists of a plastic sleeve (MCA) and a mounting arbor with 8 mm diameter shaft (K25) which is solely applicable to shape SE1 in the dimensions 10010 B 25 and 10020 B 25. It is not permitted to use this</p>		<p>mounting system for polishing wheels with larger diameters. Maximum peripheral wheel speed using this mounting method is 10m/s; this means a maximum spindle speed of 1900 R.P.M. with a wheel diameter of 100 mm.</p>	

Always the right tool



Assortment of mounted points:
I am delighted that LUKAS now offers a special line of products for retailers. Amazing packaging with most of fast moving tools to work steel and stainless steel.

Andrea Bittner
Sales Department

www.lukas-erzett.com



Industry

Marbling points, Shape ZY, Cylinder

Ordering example: A29200200306021

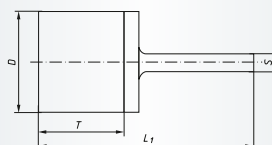
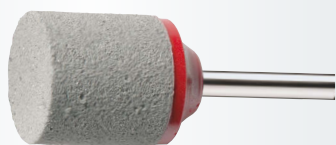

Packing unit:

1 pc. per type

Further dimensions and grit sizes on request

v_{max} : 10 m/s

Description	Quality/ Grit	D mm	T mm	S mm	L ₁ mm	Product-Number	recommended for	
P6MA ZY 2030.06	SC 46 MWP	20	30	6	65	A29200200306021	1 2 3 4 5 6 7 9	■
P6MA ZY 3030.06	SC 46 MWP	30	30	6	65	A29200300306021	1 2 3 4 5 6 7 9	■
P6MA ZY 4030.06	SC 46 MWP	40	30	6	65	A29200400306046	1 2 3 4 5 6 7 9	■
P6MA ZY 5030.06	SC 46 MWP	50	30	6	65	A29200500306046	1 2 3 4 5 6 7 9	■
P6MA ZY 6030.06	SC 46 MWP	60	30	6	65	A29200600306046	1 2 3 4 5 6 7 9	■

The marbling points can be used to work stainless steels, aluminium and non-ferrous metals (peacock-eye, clouds).

The marbling points do not load with abrasive dust and their quality lasts up to the plastic cap.



Industry

Polishing points, Shape ZY, Cylindrical

Ordering example: A29300160203028

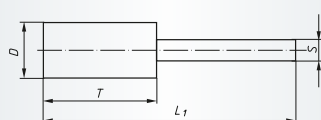
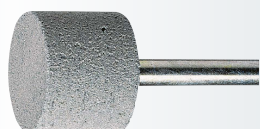

Packing unit:

10 pcs. per type

Further dimensions and grit sizes on request

v_{max} : 20 m/s

Description	Quality/ Grit	D mm	T mm	S mm	L ₁ mm	Product-Number	recommended for	
P6ZY 1320.03	SC 80 HP	13	20	3	50	A29300130203048	1 2 3 4 5 6 7 9	■
P6ZY 1620.03	SC 46 HP	16	20	3	50	A29300160203028	1 2 3 4 5 6 7 9	■
P6ZY 1620.03	SC 80 HP	16	20	3	50	A29300160203048	1 2 3 4 5 6 7 9	■
P6ZY 1620.03	SC 150 HP	16	20	3	50	A29300160203068	1 2 3 4 5 6 7 9	■
P6ZY 1620.03	SC 240 HP	16	20	3	50	A29300160203078	1 2 3 4 5 6 7 9	■
P6ZY 2020.06	SC 46 HP	20	20	6	60	A29300200206028	1 2 3 4 5 6 7 9	■
P6ZY 2020.06	SC 150 HP	20	20	6	60	A29300200206068	1 2 3 4 5 6 7 9	■
P6ZY 2520.06	SC 80 HP	25	20	6	60	A29300250206048	1 2 3 4 5 6 7 9	■
P6ZY 3030.06	SC 46 HP	30	30	6	70	A29300300306028	1 2 3 4 5 6 7 9	■
P6ZY 3030.06	SC 150 HP	30	30	6	70	A29300300306068	1 2 3 4 5 6 7 9	■
P6ZY 3030.06	SC 240 HP	30	30	6	70	A29300300306078	1 2 3 4 5 6 7 9	■
P6ZY 4040.06	SC 46 HP	40	40	6	80	A29300400406028	1 2 3 4 5 6 7 9	■
P6ZY 4040.06	SC 150 HP	40	40	6	80	A29300400406068	1 2 3 4 5 6 7 9	■
P6ZY 5040.06	SC 46 HP	50	40	6	80	A29300500406028	1 2 3 4 5 6 7 9	■
P6ZY 5040.06	SC 150 HP	50	40	6	80	A29300500406068	1 2 3 4 5 6 7 9	■
P6ZY 6040.06	SC 46 HP	60	40	6	80	A29300600406028	1 2 3 4 5 6 7 9	■
P6ZY 6040.06	SC 150 HP	60	40	6	80	A29300600406068	1 2 3 4 5 6 7 9	■

The polishing points are most suitable to work metal parts which are difficult or not accessible with grinding wheels.

Applications:

Bores, Hollow weldings, Moulding tools

160 Polishing roll, group P6



Industry

Polishing roll, P6PW

Ordering example: A29401000500041

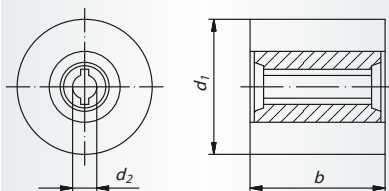

Packing unit:

1 pc. per type

Further dimensions and grit sizes on request

Machine to suit: ESM 1310

$v_{max.}$: 16 m/s

Description	Quality/ Grit	d ₁ mm	b mm	d ₂ mm	Product-Number	recommended for	
P6PW 100050	SC 80 MWP	100	50	19	A29401000500041	1 2 3 4 5 6 7 9	■
P6PW 100100	SC 46 WP	100	100	19	A29401001000020	1 2 3 4 5 6 7 9	■
P6PW 100100	SC 80 WP	100	100	19	A29401001000040	1 2 3 4 5 6 7 9	■
P6PW 100100	SC 24 MWP	100	100	19	A29401001000011	1 2 3 4 5 6 7 9	■
P6PW 100100	SC 46 MWP	100	100	19	A29401001000021	1 2 3 4 5 6 7 9	■
P6PW 100100	SC 80 MWP	100	100	19	A29401001000041	1 2 3 4 5 6 7 9	■



Industry

Conditioning machine ESM 1310

Ordering example: A3995ESM1310



Packing unit:

1 pc. per type

Weight: approx. 2,9 kg

Description	Idle speed min ⁻¹	Power input W	Max. tool diameter	Tool width mm Ø mm	Hole size mm	Product-Number	
ESM 1310	1.300 - 3.050	1.300	120	100	19	A3995ESM1310	■

Specification and application P7

LUKAS polishing points, discs and lenses have been especially developed for intricate mechanical and laboratory use. Other applications include model building and jewellery production; such highly regarded tools contain a soft elastomer bond.



The smallest dimensions in various shapes allow for the fine machining of intricate workpieces and structures.



Industry

Polishing discs and polishing lenses in a soft elastomer bonding

Ordering example: A2950000101007

		Packing unit: 100 pcs. per type Further dimensions and grit sizes on request v_{max} : 16 m/s Suitable mounting arbors on request														
Description	Quality	Shape	D mm	T mm	H mm	Product-Number	recommended for									
P7- R22 M	SICGR 240		22	3,5	1,8	A2950000101007	<table border="1"> <tr> <td>1</td><td>2</td><td>3</td><td>4</td><td>5</td><td>6</td><td>7</td><td>9</td> </tr> </table>	1	2	3	4	5	6	7	9	■
1	2	3	4	5	6	7	9									
P7- L22 M	SICGR 240		22	3,4	1,8	A2950000105007	<table border="1"> <tr> <td>1</td><td>2</td><td>3</td><td>4</td><td>5</td><td>6</td><td>7</td><td>9</td> </tr> </table>	1	2	3	4	5	6	7	9	■
1	2	3	4	5	6	7	9									



Industry

Assortment of small polishing points with soft elastomer bond mounted on shaft 2.35 mm

Ordering example: A29551301582077

		Packing unit: 1 pc. per type Individual tools available on request v_{max} : 16 m/s												
Description	Quality	Contents	Shank mm	Product-Number	recommended for									
P7-Assortment M	SICGR 240	12-pieces	2,35	A29551301582077	<table border="1"> <tr> <td>1</td><td>2</td><td>3</td><td>4</td><td>5</td><td>6</td><td>7</td><td>9</td> </tr> </table>	1	2	3	4	5	6	7	9	■
1	2	3	4	5	6	7	9							
P7-Assortment F	SICGR 400	12-pieces	2,35	A29551301582071	<table border="1"> <tr> <td>1</td><td>2</td><td>3</td><td>4</td><td>5</td><td>6</td><td>7</td><td>9</td> </tr> </table>	1	2	3	4	5	6	7	9	■
1	2	3	4	5	6	7	9							

Notes

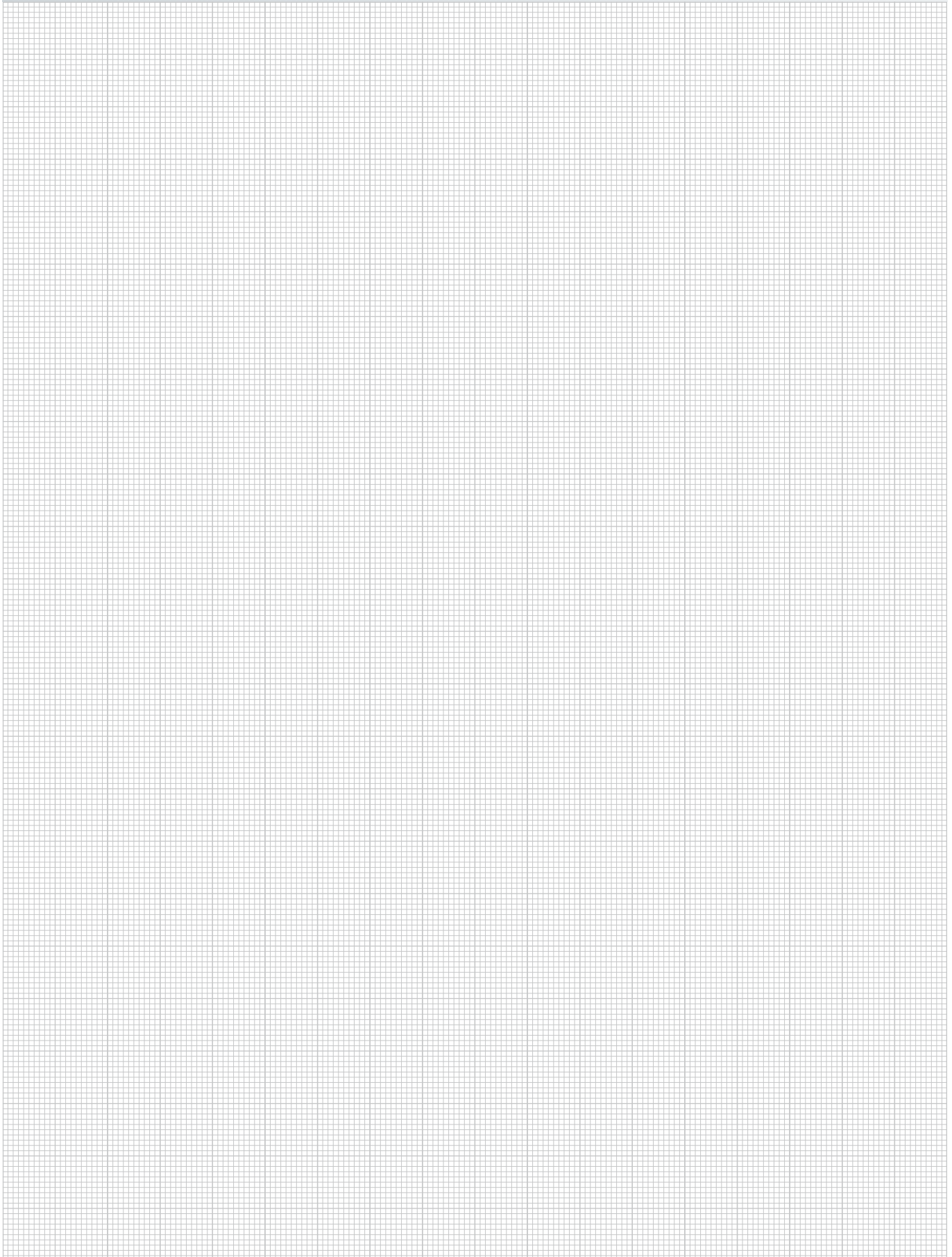
A large rectangular area filled with a fine grid pattern, intended for taking notes. The grid is composed of small, uniform squares.

Tungsten Carbide Granulate-tipped Tools

164 General Information

165 HGW-discs

165 HGW-core drills



Product line marking

Product lines are labelled in the table header with the appropriate tabs. Further information on page **14** and **15**.

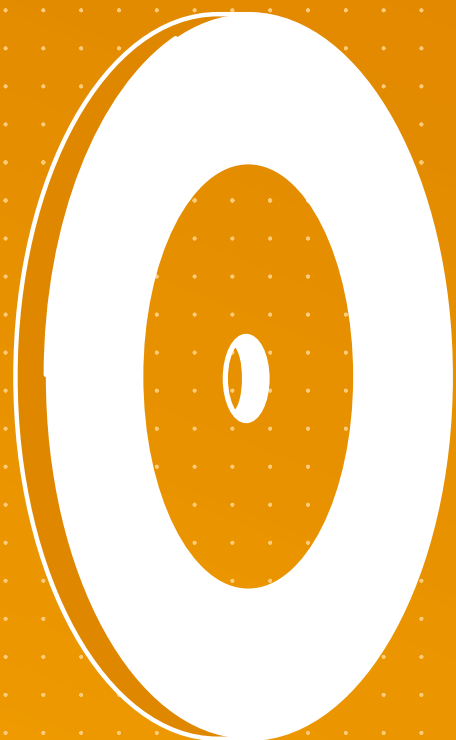

Technical Information

HGW is supplied in a wide range of grit sizes – very coarse to extra fine – and in both a dense or open structure. Please select the individual grit sizes from the table below.



Application examples

Coarse grit is used to grind soft materials; the harder the material, the finer the grit.
A special manufacturing process is used to bond the grit to the core.
Special coatings are available, but are dependent upon a wide variety of technical parameters. Please send your enquiry.

Safety regulations

We strongly recommend that use is made of machines with variable speeds in order to optimize cutting speeds; this will lie between 10-50 m/sec. depending on the material to be ground.



Industry

Tungsten Carbide Granulate-tipped disc, HGWT

Ordering example: A18031151E



Packing unit:
1 pc. per type
Further dimensions and grits on request

Description	Grit size	Type	Ø mm	Bore mm	n max. (1/min)	Product-Number	recommended for	
HGWT 115	0,3 – 0,5 E	dished	115	22,2	10.500	A18031151E		8 9 ■
HGWT 115	0,8 – 1,2 E	dished	115	22,2	10.500	A18031152E		8 9 ■
HGWT 115	1,2 – 1,8 E	dished	115	22,2	10.500	A18031153E		8 9 ■
HGWT 125	2,5 – 3,0 E	dished	125	22,2	9.600	A18031255E		8 9 ■



Industry

Core Drill-Set

Ordering example: A18300012E



Packing unit:
1 pc. per type

Description	Grit size	Description	Product-Number	recommended for	
HGWB-SET	0,8 – 1,2 E	4 core drills Ø 33, 53, 63 and 73 mm, including base plate, carbide centre point and hexagonal shank (SW9)	A18300012E		8 9 ■

Notes

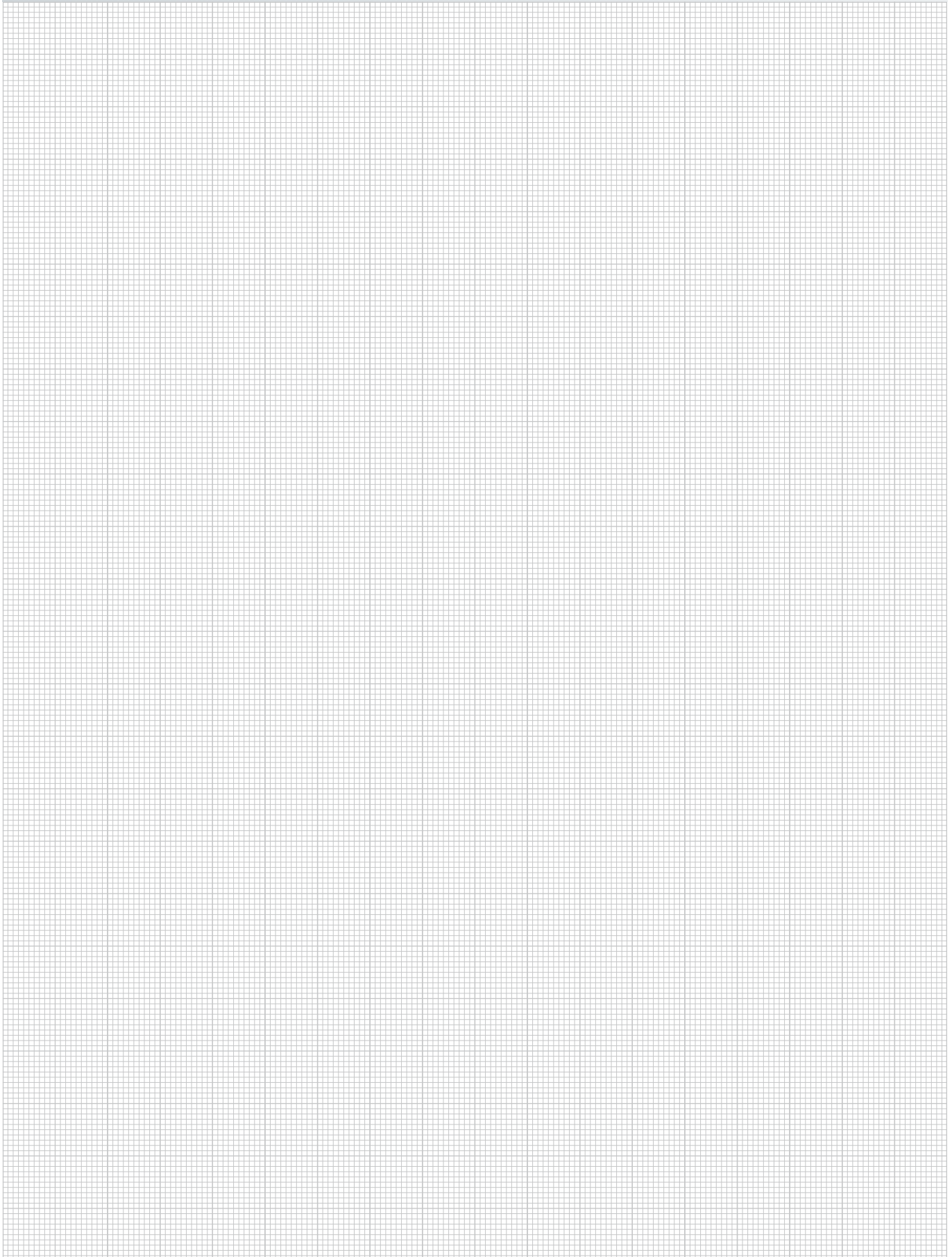

Technical Brushes

168 General Information

169 Cylindrical brush, shaft mounted

169 Cylindrical brush of abrasive nylon

170 Conical brush

170 End brush, shaft mounted

171 Pipe brush

171 Pipe brush of abrasive nylon

172 Twist knotted wheel brush

172 Cylindrical wheel brush

173 Cup wheel brush, thread mounted

173 Hand brush

381 Power tools

Product line marking

Product lines are labelled in the table header with the appropriate tabs. Further information on page **14** and **15**.

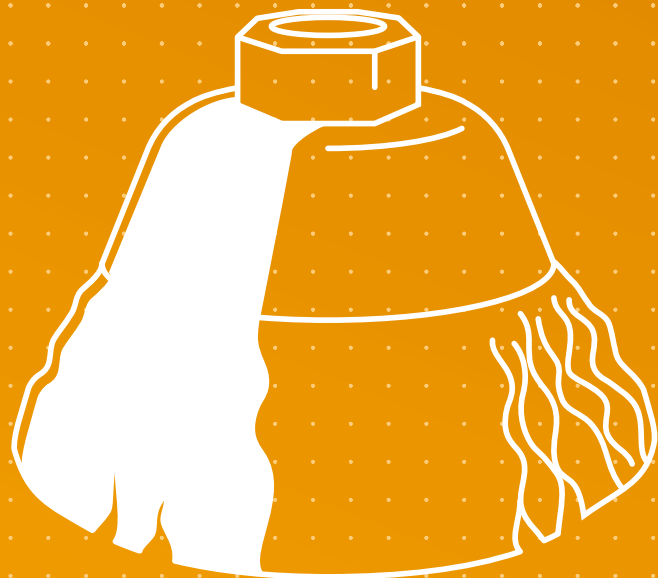

General Information

Filament Quality and Style

Quality steel wire

Using quality steel wire with a high tensile strength; this gives long and economical tool life.

Stainless steel wire

This wire is used where residues from normal steel wire would affect surfaces such as stainless steel, aluminium and other non-ferrous metals.

Nylon filaments, abrasive impregnated

Abrasive impregnated nylon filaments are very flexible and follow the contour of the workpiece without being too aggressive; in use, new abrasive is exposed to the workpiece at all times thus resulting in a constant performance and long life.

Style

Brushes are manufactured in both steel wire qualities with crimped 'or twist knotted style. Brushes with twist knotted steel wire meet the most extreme demands and normally achieve longer tool life compared to crimped wire brushes.

Brushes are also manufactured from crimped wire embedded in a resin bond. This style features higher performance and is ideally suited to achieve uniform surfaces and precise edges.

Application

Our wire brushes accommodate most of the ever increasing number of applications, like deburring, descaling, derusting, surface cleaning, fettling, roughening and paint stripping.

Brushes manufactured with abrasive impregnated nylon filaments are ideally suited to remove stain from metal surfaces, for graining of soft wood, car body repair jobs, stripping of paint residues.

Working mode and machines

Technical brushes are flexible tools which follow the contour of the workpiece.

In order to achieve best results, only the tip of the filament should be in contact with the workpiece. The elasticity of the brush depends on the exposed length of the filaments; for wire brushes, the wire diameter is an important factor. Brushes with very long filaments are extremely flexible and must be used with low pressure only. High pressure reduces the life of the brush and creates higher wear.

Technical brushes can be used on stationary and off-hand machines.

Operating speeds

Wire brushes act harder with increasing speed and softer with lower speed:

Machining of steel	approx. 30 m/s
Machining of non-ferrous metals	approx. 18–20 m/s
Machining of plastic	approx. 15 m/s

Twist knotted wire brushes may be operated at higher speeds, for instance:

Machining of steel:	approx. 40 m/s.
---------------------	-----------------

Brushes made from nylon filaments achieve best results at operating speeds between 18 and 20 m/s, depending on the material to be machined.

Safety instructions

Technical brushes are manufactured under strict quality control (according to EN 1083-2). It is recommended to wear safety clothing when working with technical brushes.



Industry

BS, Cylindrical brush, Shank 6 mm

Ordering example: A350104010111

Description		Quality	Type	d ₁ mm	b mm	l ₂ mm	Wire ø	n max. (1/min)	Product-Number	Packing unit: 10 pcs. per type								recommended for
BSSW 04010	steel	crimped	40	10	9	0,2	18.000	A350104010111	1				5			8	■	
BSVW 04011	stainless	crimped	40	11	9	0,2	18.000	A351004036		2	3	4			7		■	
BSSW 05010	steel	crimped	50	10	12	0,2	15.000	A350005026	1				5			8	■	
BSSW 05014	steel	crimped	50	14	12	0,2	15.000	A350105014111	1				5			8	■	
BSVW 05014	stainless	crimped	50	14	12	0,2	15.000	A350105014211		2	3	4			7		■	
BSSW 06018	steel	crimped	60	16	12	0,2	15.000	A350006036	1				5			8	■	
BSSW 06018	steel	crimped	60	16	17	0,3	15.000	A350106018113	1				5			8	■	
BSVW 06018	stainless	crimped	60	16	17	0,2	15.000	A351006036		2	3	4			7		■	
BSSW 07018	steel	crimped	70	16	19	0,2	15.000	A350007036	1				5			8	■	
BSSW 07018	steel	crimped	70	16	19	0,3	15.000	A350107018113	1				5			8	■	
BSVW 07018	stainless	crimped	70	16	19	0,3	15.000	A350107018213		2	3	4			7		■	
BSVW 07018	stainless	crimped	70	16	19	0,2	15.000	A351007036		2	3	4			7		■	
BSSZ 07508	steel	knotted	75	12	15	0,5	25.000	A350107508135	1				5				■	
BSVZ 07508	stainless	knotted	75	12	15	0,5	25.000	A350107508235		2	3	4					■	



Industry

BSN, Cylindrical brush of abrasive nylon, Shank 6 mm

Ordering example: A350105010048

Description		Type	d ₁ mm	b mm	l ₂ mm	n max. (1/min)	Product-Number	Packing unit: 10 pcs. per type								recommended for	
BSNG 05010	coarse		50	10	12	15.000	A350105010048		2		4		6	7	8		■
BSNF 05010	fine		50	10	12	15.000	A350105010049		2		4		6	7	8		■
BSNG 07012	coarse		70	12	20	15.000	A350107012048		2		4		6	7	8		■
BSNF 07012	fine		70	12	20	15.000	A350107012049		2		4		6	7	8		■
BSNG 10007	coarse		100	8	22	4.500	A350110007048		2		4		6	7	8		■
BSNF 10008	fine		100	8	22	4.500	A350110008050		2		4		6	7	8		■



BK, Conical brushes

Ordering example: A350610012213

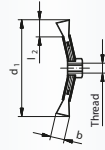

Packing unit:
10 pcs. per type

Description	Quality	Type	d ₁ mm	b mm	l ₂ mm	Thread	Wire ø	n max. (1/min)	Product-Number	recommended for	
BKVV 10012	stainless	crimped	100	10	20	M 14	0,3	12.500	A350610012213	2 3 4 7	■
BKSW 10012	steel	crimped	100	10	20	M 14	0,35	12.500	A350610012114	1 5	■
BKVZ 10013	stainless	knotted	100	13	20	M 14	0,5	12.500	A350610013235	2 3 4 7	■
BKSZ 10013	steel	knotted	100	13	20	M 14	0,5	12.500	A350610013135	1 5	■



BP, End brush, Shank 6 mm

Ordering example: A350101006

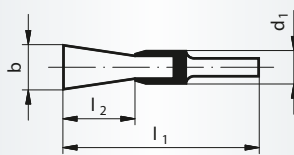

Packing unit:
10 pcs. per type

Description	Quality	Type	d ₁ mm	b mm	l ₂ mm	l ₁ mm	Wire ø	n max. (1/min)	Product-Number	recommended for	
BPSW 01020	steel	crimped	10	10	20	60	0,3	20.000	A350101006	1 5 8	■
BPVW 01020	stainless	crimped	10	10	20	60	0,3	20.000	A351101006	2 3 4 7	■
BPSW 01725	steel	crimped	16	17	22	65	0,3	20.000	A350101506	1 5 8	■
BPVW 01725	stainless	crimped	16	17	22	65	0,3	20.000	A351101506	2 3 4 7	■
BPSZ 02029	steel	knotted	19	20	28	72	0,35	20.000	A350502029134	1 5	■
BPVZ 02029	stainless	knotted	19	20	28	72	0,25	20.000	A350502029232	2 3 4 7	■
BPSW 02525	steel	crimped	22	25	25	68	0,3	18.000	A350102206	1 5 8	■
BPVW 02525	stainless	crimped	22	25	25	68	0,3	18.000	A351102206	2 3 4 7	■
BPSZ 02329	steel	knotted	22	23	28	72	0,35	20.000	A350502329134	1 5	■
BPSW 03025	steel	crimped	29	30	25	68	0,3	18.000	A350102806	1 5 8	■
BPVW 03025	stainless	crimped	29	30	25	68	0,3	18.000	A351102806	2 3 4 7	■



Industry

RBSD, pipe brush, crimped wire

Ordering example: A359901025

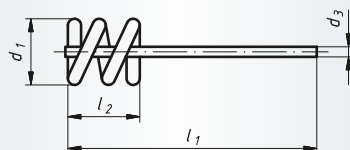

Packing unit:
10 pcs. per type

Description	Quality	Type	d ₁ mm	l ₂ mm	d ₃ mm	l ₁ mm	Wire Ø	n max. (1/min)	Product-Number	recommended for	
RBSD 1025	steel	crimped	10	25	3,8	90	0,12	2.000	A359901025	① ② ③ ⑤ ⑧	■
RBSD 1325	steel	crimped	13	25	3,8	90	0,12	2.000	A359901325	① ② ③ ⑤ ⑧	■
RBSD 1625	steel	crimped	16	25	3,8	90	0,12	2.000	A359901625	① ② ③ ⑤ ⑧	■
RBSD 2525	steel	crimped	25	25	3,8	90	0,2	2.000	A359902525	① ② ③ ⑤ ⑧	■

Ideal for

- | | |
|------------------|---------------------------|
| deburring of | polishing and cleaning of |
| • bores | • injectors/nozzles |
| • cross-holes | • small bores |
| • O-ring grooves | • threaded bores |



Industry

RBSN, pipe brush of abrasive nylon, silicon carbide

Ordering example: A359901065120

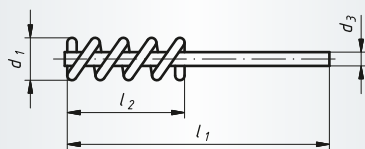
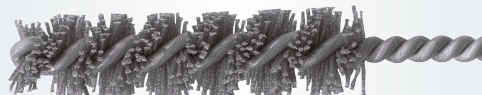

Packing unit:
10 pcs. per type

Description	Quality	d ₁ mm	l ₂ mm	d ₃ mm	l ₁ mm	Wire Ø	n max. (1/min)	Product-Number	recommended for	
RBSN 1065	C 120	10	65	3,7	125	0,6	2.000	A359901065120	② ④ ⑥ ⑦ ⑧	■
RBSN 1365	C 120	13	65	3,7	125	0,6	2.000	A359901365120	② ④ ⑥ ⑦ ⑧	■
RBSN 1665	C 120	16	65	5,2	125	0,6	2.000	A359901665120	② ④ ⑥ ⑦ ⑧	■
RBSN 2565	C 120	25	65	5,5	125	0,6	2.000	A359902565120	② ④ ⑥ ⑦ ⑧	■

Ideal for

- | | |
|------------------|---------------------------|
| deburring of | polishing and cleaning of |
| • bores | • injectors/nozzles |
| • cross-holes | • small bores |
| • O-ring grooves | • threaded bores |



BR, Wheel brush, twist knotted

Ordering example: A350211512135

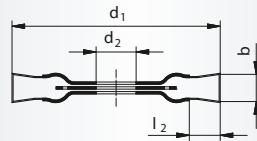

Packing unit:
1 pc. per type

Description	Quality	Type	d ₁ mm	b mm	d ₂ mm	l ₂ mm	Wire ø	n max. (1/min)	Product-Number	recommended for				
BRSZ 11512	steel	knotted	115	14	22,23	20	0,5	12.500	A350211512135	1	5	■		
BRVZ 11512	stainless	knotted	115	14	22,23	20	0,35	12.500	A350211512234	2	3	4	7	■
BRSZ 12514	steel	knotted	125	14	22,23	20	0,5	12.500	A350312514135	1	5	■		
BRVZ 12514	stainless	knotted	125	14	22,23	20	0,5	12.500	A350312514235	2	3	4	7	■
BRSZ 17814	steel	knotted	178	14	22,23	32	0,5	9.000	A350317814135	1	5	■		



BR, Wheel brush, crimped wire

Ordering example: A350315022114

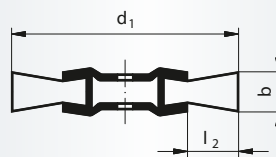

Packing unit:
1 pc. per type

Description	Quality	Type	d ₁ mm	b mm	R mm	l ₂ mm	Wire ø	n max. (1/min)	Product-Number	recommended for				
BRSW 15022	steel	crimped	150	22	40	33	0,35	6.000	A350315022114	1	5	■		
BRVW 15023	stainless	crimped	150	23	50	33	0,3	6.000	A350315023213	2	3	4	7	■
BRSW 20024	steel	crimped	200	24	50	48	0,35	6.000	A350320024114	1	5	■		

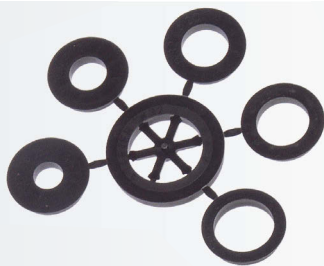

All brushes are supplied with adapters sets for easy mounting on all popular grinding machines. The adapters have the following dimensions:

tube "R" 40 mm: 40 / 32 / 1" / 22,23 / 20 / 16 1/2"

tube "R" 50 mm: 50 / 32 / 1" / 22,23 / 20 / 16 1/2"

Please take note of the technical advices for the correct and safe assembly.

The corresponding information leaflet is included in our packing.



Industry

BTG, Cup brush with thread

Ordering example: A350406021213

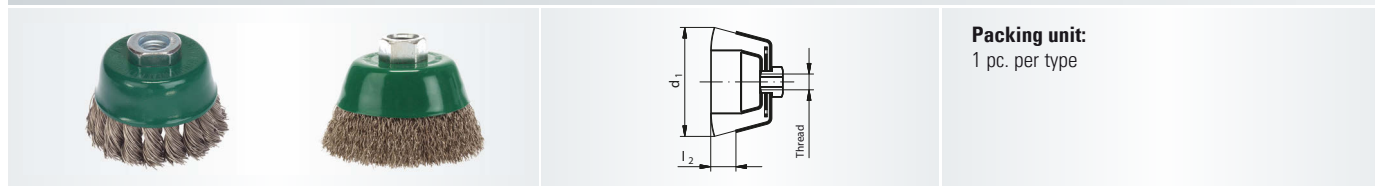

Packing unit:
1 pc. per type

Description	Quality	Type	d ₁ mm	l ₂ mm	Thread	Wire ø	n max. (1/min)	Product-Number	recommended for	
BTWV 06021 G	stainless	crimped	60	20	M 14	0,3	12.000	A350406021213	2 3 4 7	■
BTSW 06020 G	steel	crimped	60	20	M 14	0,35	12.000	A350406020114	1 5	■
BTSZ 06520 G	steel	knotted	65	20	M 14	0,5	12.500	A350406520135	1 5	■
BTVZ 06520 G	stainless	knotted	65	20	M 14	0,35	12.500	A350406520234	2 3 4 7	■
BTSZ 08020 G	steel	knotted	80	20	M 14	0,5	9.000	A350408020135	1 5	■
BTSW 08025 G	steel	crimped	80	25	M 14	0,35	8.500	A350408025114	1 5	■
BTSW 10030 G	steel	crimped	100	30	M 14	0,35	9.000	A350410030114	1 5	■



Industry

BHU, Hand brush for universal application

Ordering example: A350726525113

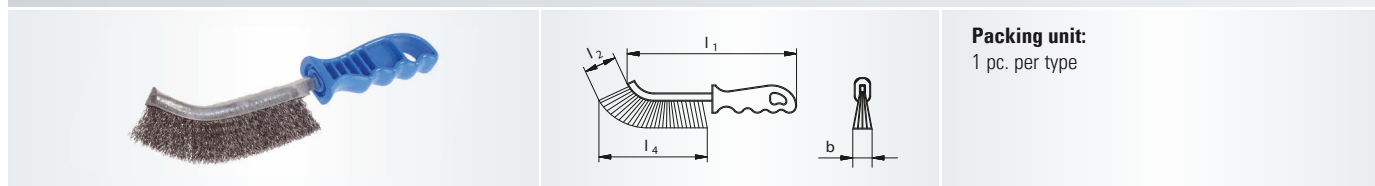

Packing unit:
1 pc. per type

Description	Quality	b mm	l ₂ mm	l ₁ mm	l ₄ mm	Wire ø	Product-Number	recommended for	
BHUS 26528	steel	15	28	265	130	0,35	A350726525113	1 5	■
BHUV 26525	stainless	15	28	265	130	0,3	A350726525213	2 3 4 7	■



"We develop and manufacture tools that meet the highest quality and safety requirements, and our modern test facility delivers reliable evidence of these standards."

Paul Lehnard

Cutting and Grinding Discs

176 Structure and Components

177 Technical Information

178 Safety

179 Labelling

181 Cutting discs

197 Grinding discs

208 Grinding cup wheels

211 Diamondtools



Product line marking

Product lines are labelled in the table header with the appropriate tabs. Further information on page **14** and **15**.

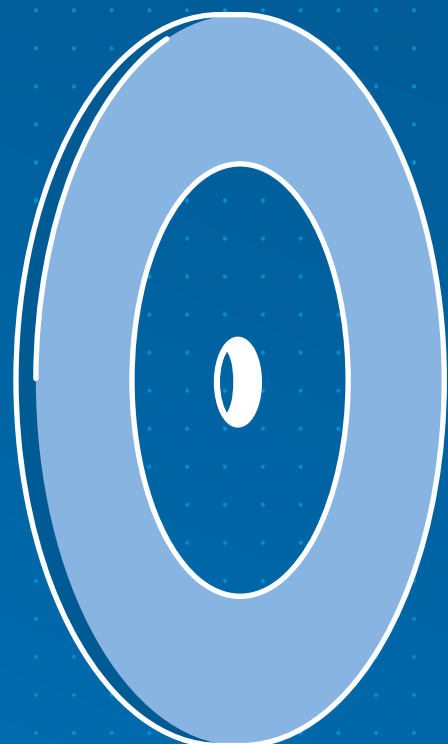

Structure and Components

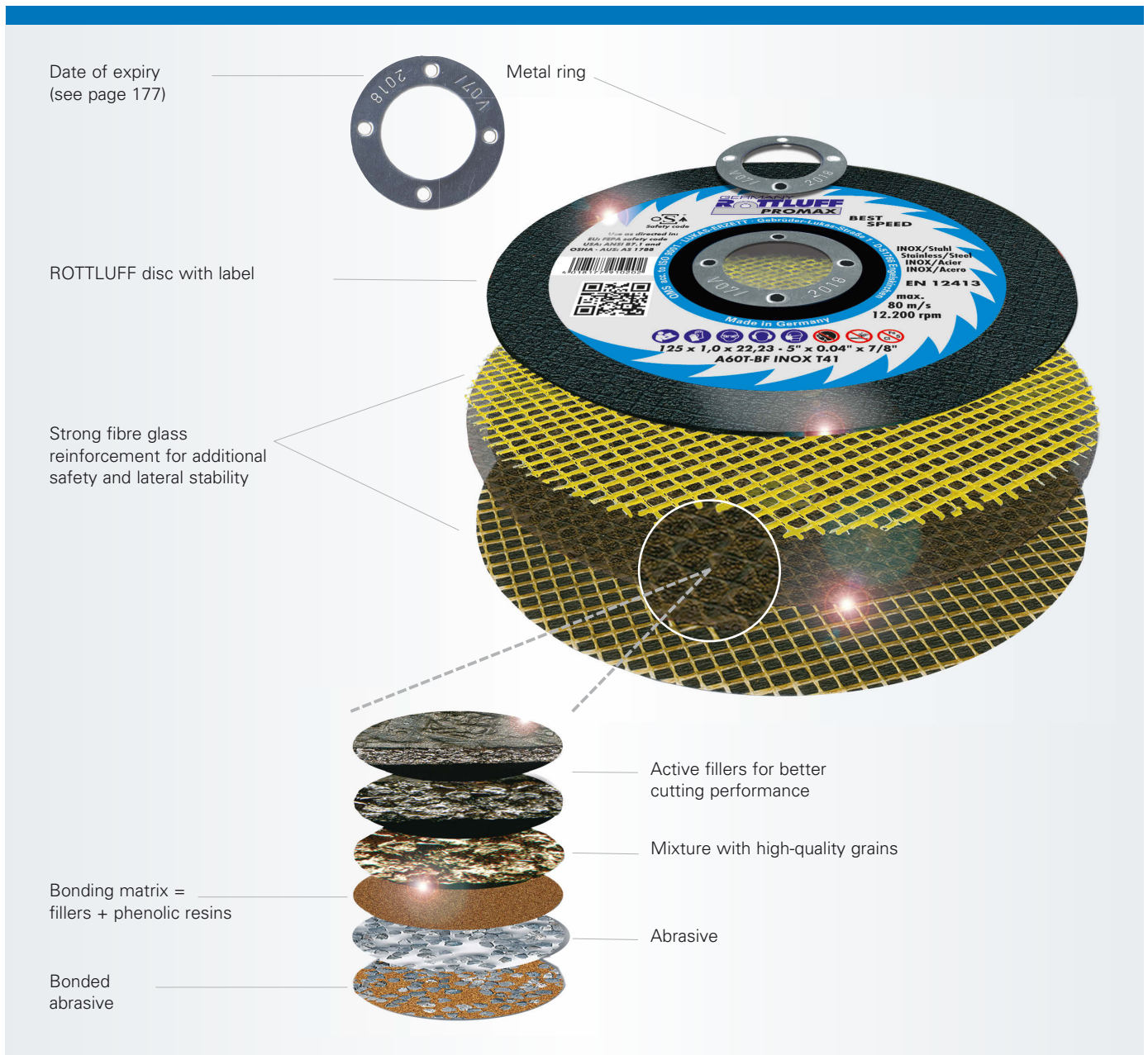

Abrasives

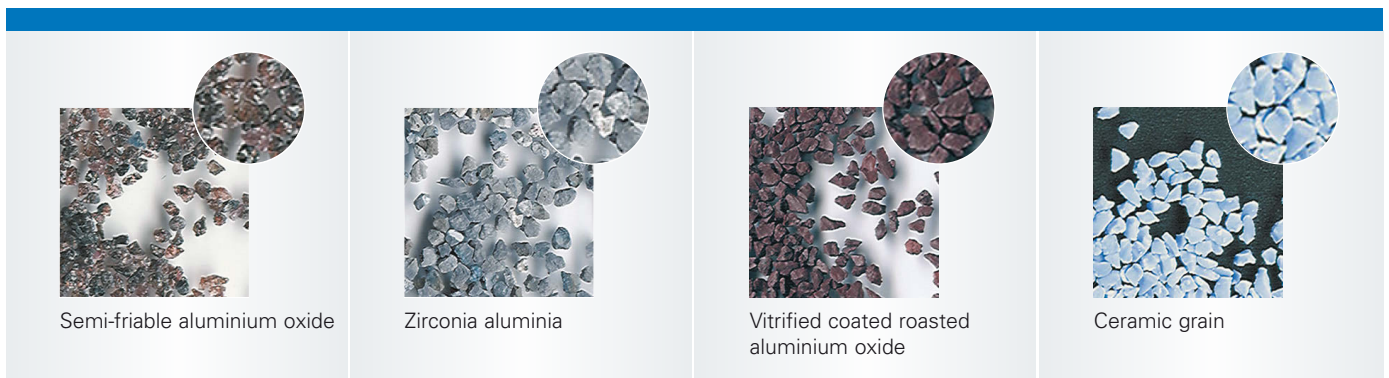

Technical Information

Durability

Resin bonded grinding and cutting wheels for freehand applications must be depleted within three years of manufacture.

Please see metal ring for the expiry date which is specified by month and year; for instance V07/2018.



Labelling system for resin bonded grinding wheels

Example:



Abrasive Type	Grit			Hardness Grade			Bond
	coarse	medium	fine	soft	medium	hard	
A - aluminium oxide	12	36	60	M	R	U	BA – resin bond
C - silicon carbide	up to	up to	up to	Q	S	V	BF – resin bond, fibre-reinforced
Z - zirconia alumina	24	54	120	P	T	Z	

Operating speeds

LUKAS- grinding wheels and discs of the brand ROTTLUFF are developed and tested for particular working speeds and grinding processes.

Prior to the mounted of the grinding tool on the machine, it must be ensured that the machine's nominal speed (as specified on nameplate) does not exceed the maximum operating speed indicated on the grinding wheel or disc.



Maximum operating speed	Diameter of Disc [mm]/RPM [min ⁻¹]										
	50	76	100	115	125	150	180	230	300	350	400
80 m/s	30.500	20.100	15.300	13.300	12.200	10.200	8.500	6.600	5.100	4.400	3.800
100 m/s	38.200	25.100	19.100	16.650	16.600	12.700	10.600	8.300	6.400	5.400	4.700

Safety

With regards to occupational safety and operational convenience, LUKAS responsibility to the customer is taken very seriously. Our products are designed, manufactured and produced in accordance with the most stringent quality standards to provide a maximum of customer value at minimum risk. We are a member of both, the German Abrasive Association (VDS) and the Organisation for the Safety of Abrasives (oSa) and thus actively contribute to users' health and safety.

Applied standards:

- Safety Requirements for Bonded Abrasives Products: EN12413
- Safety Requirements for Diamond Blades: EN 13236

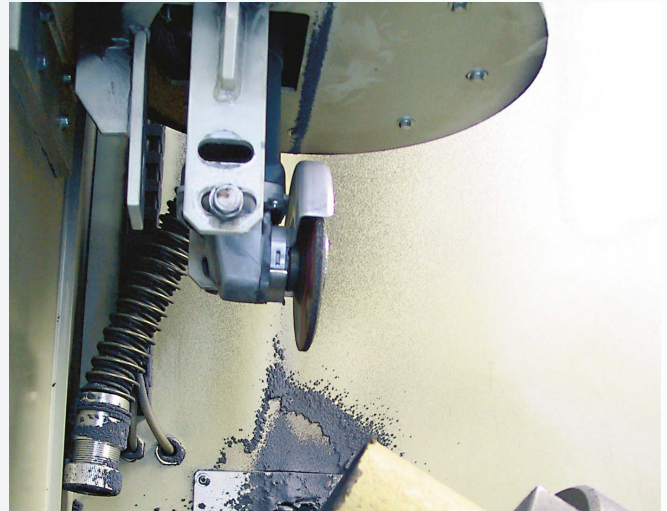

Safety recommendations

- Don't handle wheels roughly.
- Don't use non-reinforced cut-off wheels on portable machines.
- Don't store wheels in a damp atmosphere or in extreme temperatures.
- Don't mount a damaged wheel.
- Don't ever exceed the maximum operating speed marked on the wheel.
- Don't force a wheel onto a machine spindle.
- Don't use mounting flanges which are incorrect, damaged, dirty or burred.
- Don't tighten the mounting nut or locking flange excessively. To do so can distort the flanges and discs.
- Don't use a machine without a wheel guard.
- Don't use wheels without proper ventilation or dust protection equipment.
- Don't apply side pressure to cut-off wheels. You should not bend the wheel.
- Don't stop the wheel by applying pressure to the periphery or face. Always switch the machine off and allow the wheel to stop revolving.
- Don't allow the wheel to be trapped or pinched in the cut.
- Don't apply excessive pressure onto the wheel so that the driving motor slows down.
- Don't drop or lower a portable machine by the cable or airline onto the floor. A wheel can be easily cracked, if it is put down hard, by the weight of the machine. This is a common cause of wheel breakage.
- Don't grind with a depressed centre grinding wheel at an angle below 30 degrees to the work piece.
- Don't use a machine in a position where you do not have full control of the machine and you are not well balanced.

Clamping System

The use of flanges with unequal diameters is not allowed. Both flanges between which the bonded abrasive is mounted must have the same outer diameter and similar contact areas (according to EN60745-2-3:2007 and ANSI B.7.1).

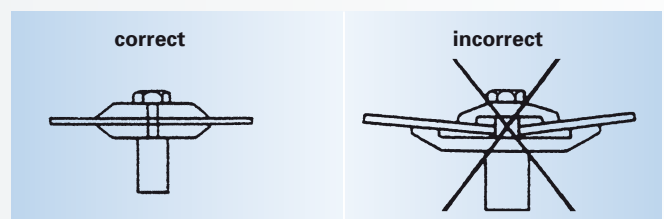

Rottluff-Labeling

Safety standard

Safety code

Use as directed in:
EU: FEPA safety code
USA: ANSI B7.1 and OSHA · AUS: AS 1788

EAN Code

QR Code

Safety and operation Instructions

A = Aluminium oxide
C = Silicon carbide
AC = Aluminium oxide / Silicon carbide
ZA = zirconia alumina / aluminium oxide

60 = Grit size (16/very coarse, 36/medium, 60/Fine)

BF = resin bond, fibre-reinforced

HCS see page 183

Application

Manufactured according to EN 12413

max. operating speed

max. rpm

125 x 1,0 x 22,23 = D x U x H
5" x 0,04" x 7/8" = D x U x H
Diameter x thickness x bore size

Types of resin-bonded grinding wheels

<p>Cutting discs U = (0,8 mm–4,5 mm) (USA: Typ 1)</p> <p>T 41 Straight cutting discs.</p> <ul style="list-style-type: none"> Available in diameters from 50 (2") to 230 mm (9") for freehand applications from 300 mm (12") to 500 mm (20") for use in stationary machines 	<p>Cutting discs U = (0,8 mm–4,5 mm) (USA: Typ 27)</p> <p>T 42 Depressed centre cutting discs.</p> <ul style="list-style-type: none"> Available in diameters from 76 (3") to 230 mm (9"), allowed for freehand use. 	<p>Grinding wheels U = (3 mm–10 mm) (USA: Typ 27)</p> <p>T 27 Depressed centre grinding wheels.</p> <ul style="list-style-type: none"> Available in diameters from 76 (3") to 230 mm (9"), allowed for freehand use.
--	--	---

Notes

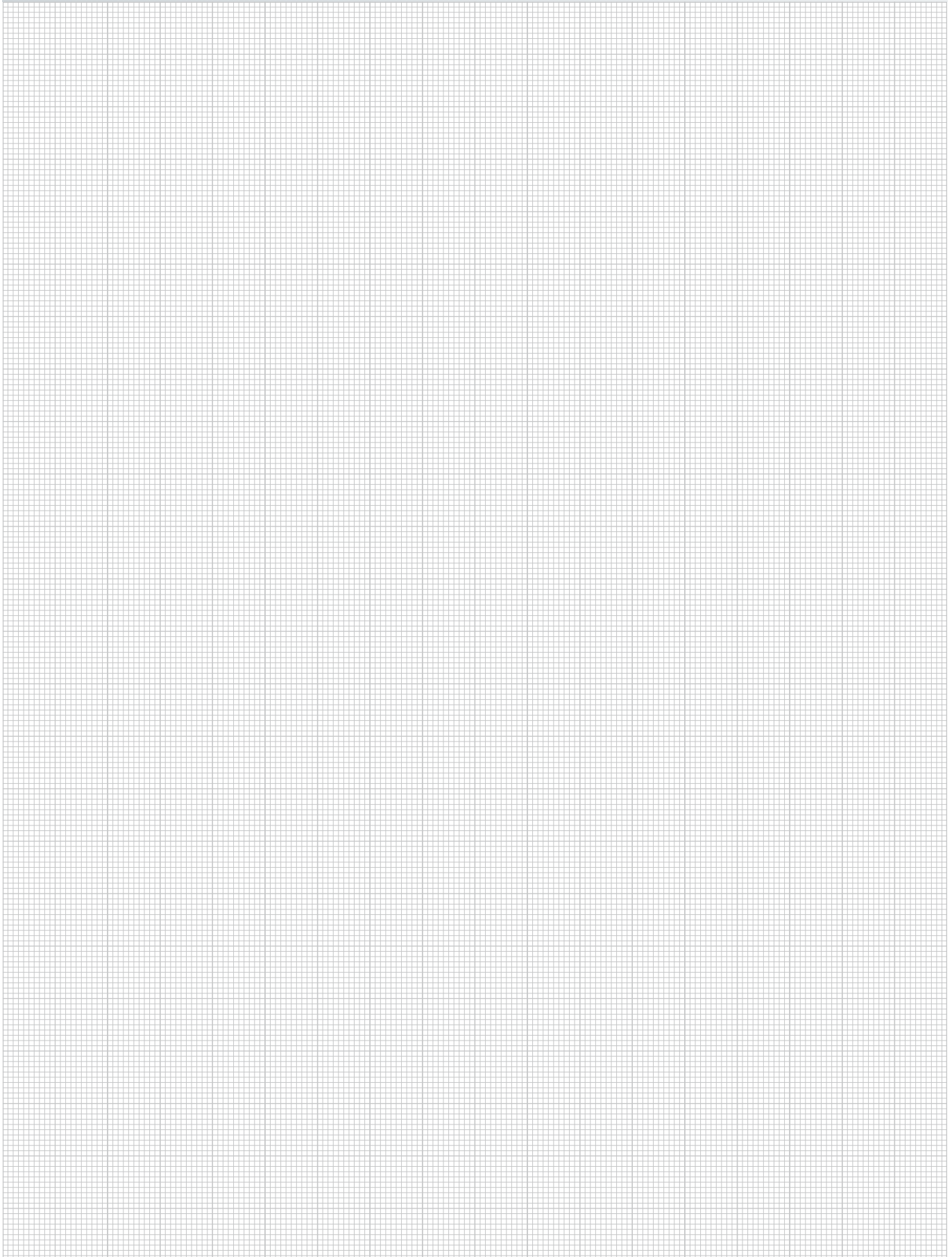

Cutting discs

- **182** Qualities and areas of application
- **184** Free-hand cutting disc for angle grinders
- **192** Large cutting disc (greater than 230 mm)
- **195** Small cutting disc (less than 100 mm)







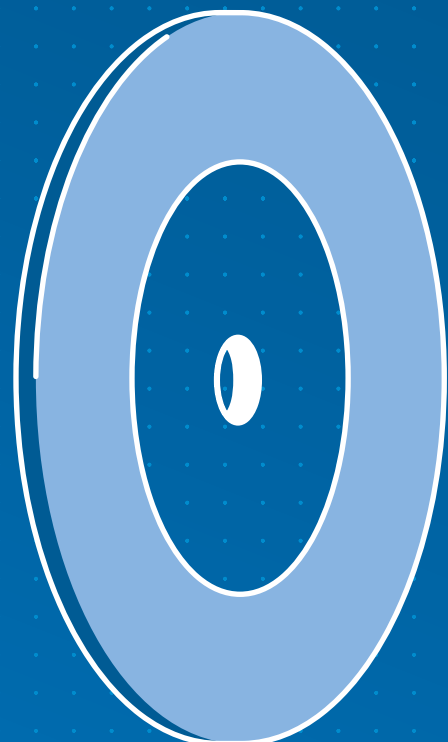



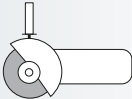







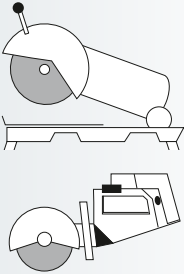

Product line marking

Product lines are labelled in the table header with the appropriate tabs. Further information on page **14** and **15**.



Cutting discs

Type	Product line	Material				
		INOX/Steel	Steel	Aluminium	Stone/Cast material	
Free-hand cutting disc for angle grinders (100 mm–230 mm) 	High Performance					
	PROGRESS	Page 184 	Page 187 			
	Industry					
	PROMAX	Page 185 	Page 188 	Page 191 	Page 191 	
	Base					
	PREMIUMFLEX BASE-X	Page 186-187 	Page 189-190 		Page 192 	
Large cutting disc (greater than 230 mm) 	Industry					
	PROMAX		Page 189 			
	Base					
	PREMIUMFLEX BASE-X	Page 192 	Page 193 		Page 194 	
	Small cutting disc (less than 100 mm) 	High Performance				
		PROGRESS	Page 195 			
Base						
PREMIUMFLEX BASE-X		Page 195 				

HighCut-Solution – HCS

optimum cutting performance and service life

low odour and dust levels

durable stable with regard to quality

optimised for top performance



- maximum service life and cutting performance due to innovative bonding technology
- high cutting speed at low cutting temperature
- low odour and dust levels during daily usage
- ergonomic work position and maximum durability without use of excessive force
- maximum shelf life with high levels of stability with regard to quality thanks to top quality raw materials
- energy optimised for your high performance angle grinders
- environmentally friendly manufacturing process, made in Germany using up-to-date production processes and optimised formulations
- perfect for a wide variety of Inox and steel materials
- precise cutting

BEST SPEED and BEST LIFE – it's your choice!

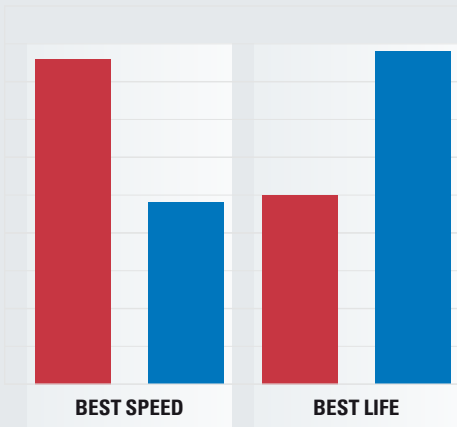

The chart shows two groups of bars. The first group, labeled 'BEST SPEED', has a tall red bar (Cutting speed) and a shorter blue bar (Service life). The second group, labeled 'BEST LIFE', has a shorter red bar (Cutting speed) and a tall blue bar (Service life). A legend at the bottom indicates red for Cutting speed and blue for Service life.

Our tools are consistently designed for high performance. But as application parameters and expectations of our cutting and grinding discs can differ considerably, we offer two variants:

BEST SPEED is the right choice for all those who want quick results. Shorter cutting and grinding times ensure that work progresses with speed.

BEST LIFE ensures a high cutting rate per tool and optimises tool changing intervals.

Packing units

Diameter (mm)	Disc width (mm)	Packing units
50–76	all	100 pieces
100–125	< 2	50 pieces (BASE-X 100 pieces)
	≥ 2	25 pieces
150–300	all	25 pieces
300–350	all	10 pieces
400	all	5 pieces

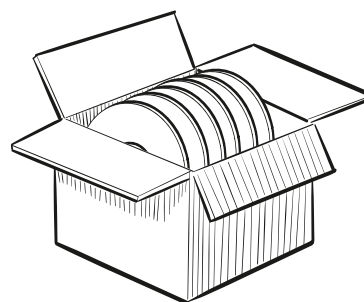

Cutting discs for stainless steel – PROGRESS

Ordering example: AT007226

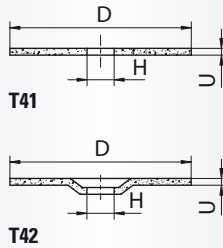

Packing unit:
see page 183

T41 = flat

T42 = depressed centre

Iron, sulphur and chlorine < 0,1%

v_{max.}: 80 m/s

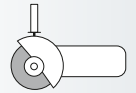

	Description	Quality	Variant	Ø D mm	Thickness U mm	Bore H mm	n max. (1/min)	Product-Number	recommended for	
NEW	T41 PROGRESS	A60Z-BF INOX	HCS	100	1,0	16,00	15.300	AT007226	1 2 3 4 5 6 7	■
NEW	T42 PROGRESS	A60Z-BF INOX	HCS	100	1,0	16,00	15.300	AT007227	1 2 3 4 5 6 7	■
NEW	T41 PROGRESS	A46Z-BF INOX	HCS	100	1,6	16,00	15.300	AT007228	1 2 3 4 5 6 7	■
NEW	T42 PROGRESS	A46Z-BF INOX	HCS	100	1,6	16,00	15.300	AT007229	1 2 3 4 5 6 7	■
NEW	T41 PROGRESS	A60Z-BF INOX	HCS	115	1,0	22,23	13.300	AT007231	1 2 3 4 5 6 7	■
NEW	T42 PROGRESS	A60Z-BF INOX	HCS	115	1,0	22,23	13.300	AT007232	1 2 3 4 5 6 7	■
NEW	T41 PROGRESS	A46Z-BF INOX	HCS	115	1,6	22,23	13.300	AT007235	1 2 3 4 5 6 7	■
NEW	T42 PROGRESS	A46Z-BF INOX	HCS	115	1,6	22,23	13.300	AT007236	1 2 3 4 5 6 7	■
NEW	T41 PROGRESS	A30Z-BF INOX	HCS	115	2,5	22,23	13.300	AT007211	1 2 3 4 5 6 7	■
NEW	T42 PROGRESS	A30Z-BF INOX	HCS	115	2,5	22,23	13.300	AT007212	1 2 3 4 5 6 7	■
NEW	T41 PROGRESS	A60Z-BF INOX	HCS	125	1,0	22,23	12.200	AT007233	1 2 3 4 5 6 7	■
NEW	T42 PROGRESS	A60Z-BF INOX	HCS	125	1,0	22,23	12.200	AT007234	1 2 3 4 5 6 7	■
NEW	T41 PROGRESS	A46Z-BF INOX	HCS	125	1,6	22,23	12.200	AT007237	1 2 3 4 5 6 7	■
NEW	T42 PROGRESS	A46Z-BF INOX	HCS	125	1,6	22,23	12.200	AT007238	1 2 3 4 5 6 7	■
NEW	T41 PROGRESS	A30Z-BF INOX	HCS	125	2,5	22,23	12.200	AT007213	1 2 3 4 5 6 7	■
NEW	T42 PROGRESS	A30Z-BF INOX	HCS	125	2,5	22,23	12.200	AT007214	1 2 3 4 5 6 7	■
NEW	T41 PROGRESS	A60Z-BF INOX	HCS	150	1,0	22,23	10.200	AT007239	1 2 3 4 5 6 7	■
NEW	T42 PROGRESS	A60Z-BF INOX	HCS	150	1,0	22,23	10.200	AT007240	1 2 3 4 5 6 7	■
NEW	T41 PROGRESS	A46Z-BF INOX	HCS	150	1,6	22,23	10.200	AT007241	1 2 3 4 5 6 7	■
NEW	T42 PROGRESS	A46Z-BF INOX	HCS	150	1,6	22,23	10.200	AT007242	1 2 3 4 5 6 7	■
NEW	T41 PROGRESS	A30Z-BF INOX	HCS	150	2,5	22,23	10.200	AT007215	1 2 3 4 5 6 7	■
NEW	T42 PROGRESS	A30Z-BF INOX	HCS	150	2,5	22,23	10.200	AT007216	1 2 3 4 5 6 7	■
NEW	T41 PROGRESS	A46Z-BF INOX	HCS	180	1,6	22,23	8.500	AT007243	1 2 3 4 5 6 7	■
NEW	T42 PROGRESS	A46Z-BF INOX	HCS	180	1,6	22,23	8.500	AT007244	1 2 3 4 5 6 7	■
NEW	T41 PROGRESS	A30Z-BF INOX	HCS	180	2,5	22,23	8.500	AT007217	1 2 3 4 5 6 7	■
NEW	T42 PROGRESS	A30Z-BF INOX	HCS	180	2,5	22,23	8.500	AT007218	1 2 3 4 5 6 7	■
NEW	T41 PROGRESS	A46Z-BF INOX	HCS	230	1,9	22,23	6.600	AT007245	1 2 3 4 5 6 7	■
NEW	T42 PROGRESS	A46Z-BF INOX	HCS	230	1,9	22,23	6.600	AT007246	1 2 3 4 5 6 7	■
NEW	T41 PROGRESS	A30Z-BF INOX	HCS	230	2,5	22,23	6.600	AT007219	1 2 3 4 5 6 7	■
NEW	T42 PROGRESS	A30Z-BF INOX	HCS	230	2,5	22,23	6.600	AT007220	1 2 3 4 5 6 7	■

Cutting discs for stainless steel – PROMAX

Ordering example: AT001634

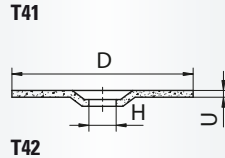
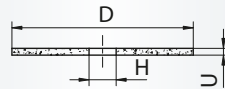

Packing unit:

see page 183

T41 = flat

T42 = depressed centre

Iron, sulphur and chlorine < 0,1%

v_{max.}: 80 m/s

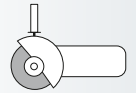

Description	Quality	Variant	Ø D mm	Thickness U mm	Bore H mm	n max. (1/min)	Product-Number	recommended for									
T41 PROMAX	A60T-BF INOX	BEST SPEED	100	1,0	16,00	15.300	AT001634	1	2	3	4	5	6	7			■
T41 PROMAX	A60X-BF INOX	BEST LIFE	100	1,0	16,00	15.300	AT003000	1	2	3	4	5	6	7			■
T42 PROMAX	A60T-BF INOX	BEST SPEED	115	0,8	22,23	13.300	AT004266	1	2	3	4	5	6	7			■
T42 PROMAX	A60X-BF INOX	BEST LIFE	115	0,8	22,23	13.300	AT005301	1	2	3	4	5	6	7			■
T41 PROMAX	A60T-BF INOX	BEST SPEED	115	1,0	22,23	13.300	AT001655	1	2	3	4	5	6	7			■
T41 PROMAX	A60X-BF INOX	BEST LIFE	115	1,0	22,23	13.300	AT005841	1	2	3	4	5	6	7			■
T42 PROMAX	A60X-BF INOX	BEST LIFE	115	1,0	22,23	13.300	AT005299	1	2	3	4	5	6	7			■
T41 PROMAX	A46X-BF INOX	BEST LIFE	115	1,6	22,23	13.300	AT003346	1	2	3	4	5	6	7			■
T42 PROMAX	A46X-BF INOX	BEST LIFE	115	1,6	22,23	13.300	AT003347	1	2	3	4	5	6	7			■
T41 PROMAX	A36U-BF INOX	BEST LIFE	115	2,0	22,23	13.300	AT001657	1	2	3	4	5	6	7			■
T42 PROMAX	A60T-BF INOX	BEST SPEED	125	0,8	22,23	12.200	AT005287	1	2	3	4	5	6	7			■
T42 PROMAX	A60X-BF INOX	BEST LIFE	125	0,8	22,23	12.200	AT005302	1	2	3	4	5	6	7			■
T41 PROMAX	A60T-BF INOX	BEST SPEED	125	1,0	22,23	12.200	AT001685	1	2	3	4	5	6	7			■
T41 PROMAX	A60X-BF INOX	BEST LIFE	125	1,0	22,23	12.200	AT005842	1	2	3	4	5	6	7			■
T42 PROMAX	A60X-BF INOX	BEST LIFE	125	1,0	22,23	12.200	AT005300	1	2	3	4	5	6	7			■
T41 PROMAX	A46X-BF INOX	BEST LIFE	125	1,6	22,23	12.200	AT003348	1	2	3	4	5	6	7			■
T42 PROMAX	A46X-BF INOX	BEST LIFE	125	1,6	22,23	12.200	AT003353	1	2	3	4	5	6	7			■
T41 PROMAX	A36U-BF INOX	BEST LIFE	125	2,0	22,23	12.200	AT001687	1	2	3	4	5	6	7			■
T41 PROMAX	A30U-BF INOX	BEST LIFE	125	2,5	22,23	12.200	AT001691	1	2	3	4	5	6	7			■
T42 PROMAX	A30U-BF INOX	BEST LIFE	125	2,5	22,23	12.200	AT001696	1	2	3	4	5	6	7			■
T42 PROMAX	A60X-BF INOX	BEST LIFE	150	1,0	22,23	10.200	AT004221	1	2	3	4	5	6	7			■
T41 PROMAX	A46X-BF INOX	BEST LIFE	150	1,6	22,23	10.200	AT003327	1	2	3	4	5	6	7			■
T42 PROMAX	A30U-BF INOX	BEST LIFE	150	2,5	22,23	10.200	AT001725	1	2	3	4	5	6	7			■
T42 PROMAX	A46X-BF INOX	BEST LIFE	180	1,6	22,23	8.500	AT005571	1	2	3	4	5	6	7			■
T41 PROMAX	A36U-BF INOX	BEST LIFE	180	2,0	22,23	8.500	AT001743	1	2	3	4	5	6	7			■
T42 PROMAX	A30U-BF INOX	BEST LIFE	180	2,5	22,23	8.500	AT001751	1	2	3	4	5	6	7			■
T41 PROMAX	A46X-BF INOX	BEST LIFE	230	1,9	22,23	6.600	AT005864	1	2	3	4	5	6	7			■
T42 PROMAX	A46X-BF INOX	BEST LIFE	230	1,9	22,23	6.600	AT005877	1	2	3	4	5	6	7			■
T41 PROMAX	A36U-BF INOX	BEST LIFE	230	2,0	22,23	6.600	AT001782	1	2	3	4	5	6	7			■
T41 PROMAX	A30U-BF INOX	BEST LIFE	230	2,5	22,23	6.600	AT001786	1	2	3	4	5	6	7			■
T42 PROMAX	A30U-BF INOX	BEST LIFE	230	2,5	22,23	6.600	AT001791	1	2	3	4	5	6	7			■

NEW

NEW

NEW

NEW

NEW

NEW

NEW

NEW

NEW

Cutting discs for stainless steel – PREMIUMFLEX

Ordering example: AT003108

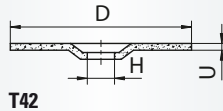
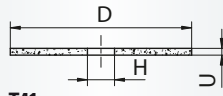

Packing unit:

see page 183

T41 = flat

T42 = depressed centre

Iron, sulphur and chlorine < 0,1%

v_{max.}: 80 m/s

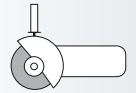

Description	Quality	Variant	Ø D mm	Thickness U mm	Bore H mm	n max. (1/min)	Product-Number	recommended for									
T41 PREMIUMFLEX	A60S-BF INOX	BEST LIFE	100	1,0	16,00	15.300	AT003108	1	2	3	4	5	6	7			■
T41 PREMIUMFLEX	A46T-BF INOX	BEST LIFE	100	1,6	16,00	15.300	AT000630	1	2	3	4	5	6	7			■
T41 PREMIUMFLEX	A60S-BF INOX	BEST LIFE	115	1,0	22,23	13.300	AT004643	1	2	3	4	5	6	7			■
T41 PREMIUMFLEX	A46T-BF INOX	BEST LIFE	115	1,2	22,23	13.300	AT000643	1	2	3	4	5	6	7			■
T42 PREMIUMFLEX	A46P-BF INOX	BEST SPEED	115	1,6	22,23	13.300	AT003461	1	2	3	4	5	6	7			■
T41 PREMIUMFLEX	A46T-BF INOX	BEST LIFE	115	1,6	22,23	13.300	AT000647	1	2	3	4	5	6	7			■
NEW T42 PREMIUMFLEX	A24/30S-BF INOX	BEST LIFE	115	2,5	22,23	13.300	AT001442	1	2	3	4	5	6	7			■
T41 PREMIUMFLEX	A60S-BF INOX	BEST LIFE	125	1,0	22,23	12.200	AT002672	1	2	3	4	5	6	7			■
T41 PREMIUMFLEX	A46T-BF INOX	BEST LIFE	125	1,2	22,23	12.200	AT000670	1	2	3	4	5	6	7			■
T41 PREMIUMFLEX	A46T-BF INOX	BEST LIFE	125	1,6	22,23	12.200	AT000674	1	2	3	4	5	6	7			■
T41 PREMIUMFLEX	A24/30S-BF INOX	BEST LIFE	125	2,5	22,23	12.200	AT004154	1	2	3	4	5	6	7			■
NEW T42 PREMIUMFLEX	A24/30S-BF INOX	BEST LIFE	125	2,5	22,23	12.200	AT004157	1	2	3	4	5	6	7			■
T42 PREMIUMFLEX	A24/30S-BF INOX	BEST LIFE	125	3,0	22,23	12.200	AT010154	1	2	3	4	5	6	7			■
T41 PREMIUMFLEX	A46T-BF INOX	BEST LIFE	150	1,6	22,23	10.200	AT000700	1	2	3	4	5	6	7			■
NEW T41 PREMIUMFLEX	A24/30S-BF INOX	BEST LIFE	150	2,5	22,23	10.200	AT003162	1	2	3	4	5	6	7			■
T41 PREMIUMFLEX	A46T-BF INOX	BEST LIFE	180	1,6	22,23	8.500	AT000716	1	2	3	4	5	6	7			■
T42 PREMIUMFLEX	A46T-BF INOX	BEST LIFE	180	1,6	22,23	8.500	AT000718	1	2	3	4	5	6	7			■
T41 PREMIUMFLEX	A24/30S-BF INOX	BEST LIFE	180	2,5	22,23	8.500	AT003723	1	2	3	4	5	6	7			■
T42 PREMIUMFLEX	A24/30S-BF INOX	BEST LIFE	180	2,5	22,23	8.500	AT005450	1	2	3	4	5	6	7			■
T42 PREMIUMFLEX	A24/30S-BF INOX	BEST LIFE	180	3,0	22,23	8.500	AT003163	1	2	3	4	5	6	7			■
T42 PREMIUMFLEX	A46P-BF INOX	BEST SPEED	230	1,9	22,23	6.600	AT003475	1	2	3	4	5	6	7			■
T41 PREMIUMFLEX	A46T-BF INOX	BEST LIFE	230	1,9	22,23	6.600	AT000742	1	2	3	4	5	6	7			■
T42 PREMIUMFLEX	A46T-BF INOX	BEST LIFE	230	1,9	22,23	6.600	AT000744	1	2	3	4	5	6	7			■
T41 PREMIUMFLEX	A24/30S-BF INOX	BEST LIFE	230	2,5	22,23	6.600	AT003568	1	2	3	4	5	6	7			■
NEW T42 PREMIUMFLEX	A24/30S-BF INOX	BEST LIFE	230	2,5	22,23	6.600	AT005451	1	2	3	4	5	6	7			■
T42 PREMIUMFLEX	A24/30S-BF INOX	BEST LIFE	230	3,0	22,23	6.600	AT004168	1	2	3	4	5	6	7			■

Cutting discs for stainless steel – BASE-X

Ordering example: A3890101150122002

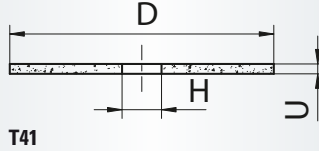

Packing unit:
see page 183
T41 = flat
T42 = depressed centre
Iron, sulphur and chlorine < 0,1%
v_{max.}: 80 m/s

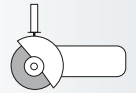

Description	Quality	Ø D mm	Thickness U mm	Bore H mm	n max. (1/min)	Product-Number	recommended for	
T41 BASE-X	A60T-BF INOX	115	1,0	22,23	13.300	A3890101150122002	1 2 3 4 5 6 7	■
T41 BASE-X	A60T-BF INOX	125	1,0	22,23	12.200	A3890101250122002	1 2 3 4 5 6 7	■
T41 BASE-X	A46T-BF INOX	230	1,8	22,23	6.600	A3890102300122002	1 2 3 4 5 6 7	■

Cutting discs for metal – PROGRESS

Ordering example: AT007276

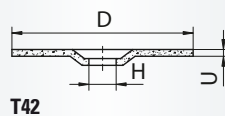
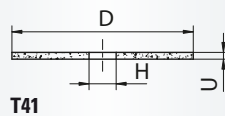

Packing unit:
see page 183
T41 = flat
T42 = depressed centre
v_{max.}: 80 m/s

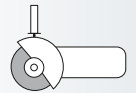

Description	Quality	Variant	Ø D mm	Thickness U mm	Bore H mm	n max. (1/min)	Product-Number	recommended for		
T41 PROGRESS	A60Z-BF	HCS	115	1,0	22,23	13.300	AT007276	1 2 3 5	■	NEW
T42 PROGRESS	A60Z-BF	HCS	115	1,0	22,23	13.300	AT007277	1 2 3 5	■	NEW
T41 PROGRESS	A46Z-BF	HCS	115	1,6	22,23	13.300	AT007271	1 2 3 5	■	NEW
T42 PROGRESS	A46Z-BF	HCS	115	1,6	22,23	13.300	AT007272	1 2 3 5	■	NEW
T41 PROGRESS	A60Z-BF	HCS	125	1,0	22,23	12.200	AT007278	1 2 3 5	■	NEW
T42 PROGRESS	A60Z-BF	HCS	125	1,0	22,23	12.200	AT007279	1 2 3 5	■	NEW
T41 PROGRESS	A46Z-BF	HCS	125	1,6	22,23	12.200	AT007273	1 2 3 5	■	NEW
T42 PROGRESS	A46Z-BF	HCS	125	1,6	22,23	12.200	AT007274	1 2 3 5	■	NEW
T41 PROGRESS	A46Z-BF	HCS	230	1,9	22,23	6.600	AT007284	1 2 3 5	■	NEW
T42 PROGRESS	A46Z-BF	HCS	230	1,9	22,23	6.600	AT007285	1 2 3 5	■	NEW

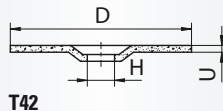
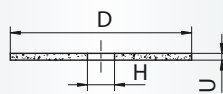
Cutting discs for metal – PROMAX
Ordering example: AT000556

Packing unit:

see page 183

T41 = flat

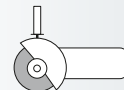
T42 = depressed centre

 $v_{max.}: 80 \text{ m/s}$

Description	Quality	Variant	Ø D mm	Thickness U mm	Bore H mm	n max. (1/min)	Product-Number	recommended for									
T41 PROMAX	A36U-BF	BEST SPEED	100	2,0	16,00	15.300	AT000556	1	2	3	5						■
T41 PROMAX	A60X-BF	BEST LIFE	115	1,0	22,23	13.300	AT005840	1	2	3	5						■
T41 PROMAX	A46X-BF	BEST LIFE	115	1,6	22,23	13.300	AT013301	1	2	3	5						■
T41 PROMAX	A36U-BF	BEST SPEED	115	2,0	22,23	13.300	AT001656	1	2	3	5						■
T42 PROMAX	A30U-BF	BEST SPEED	115	2,5	22,23	13.300	AT001665	1	2	3	5						■
T41 PROMAX	A60X-BF	BEST LIFE	125	1,0	22,23	12.200	AT005835	1	2	3	5						■
T41 PROMAX	A46X-BF	BEST LIFE	125	1,6	22,23	12.200	AT013302	1	2	3	5						■
T41 PROMAX	A36U-BF	BEST SPEED	125	2,0	22,23	12.200	AT001686	1	2	3	5						■
T41 PROMAX	A30U-BF	BEST SPEED	125	2,5	22,23	12.200	AT001690	1	2	3	5						■
T42 PROMAX	A30U-BF	BEST SPEED	125	2,5	22,23	12.200	AT001695	1	2	3	5						■
T41 PROMAX	A30X-BF	BEST LIFE	125	2,5	22,23	12.200	AT011086	1	2	3	5						■
T41 PROMAX	A46X-BF	BEST LIFE	150	1,6	22,23	10.200	AT013303	1	2	3	5						■
T41 PROMAX	A36U-BF	BEST SPEED	150	2,0	22,23	10.200	AT001717	1	2	3	5						■
T41 PROMAX	A30U-BF	BEST SPEED	150	2,5	22,23	10.200	AT001720	1	2	3	5						■
T42 PROMAX	A30U-BF	BEST SPEED	150	2,5	22,23	10.200	AT001724	1	2	3	5						■
NEW T41 PROMAX	A46X-BF	BEST LIFE	180	1,6	22,23	8.500	AT013305	1	2	3	5						■
T41 PROMAX	A36U-BF	BEST SPEED	180	2,0	22,23	8.500	AT001742	1	2	3	5						■
T41 PROMAX	A30U-BF	BEST SPEED	180	2,5	22,23	8.500	AT001746	1	2	3	5						■
T42 PROMAX	A36U-BF	BEST SPEED	180	2,0	22,23	8.500	AT001744	1	2	3	5						■
T42 PROMAX	A30U-BF	BEST SPEED	180	2,5	22,23	8.500	AT001750	1	2	3	5						■
T41 PROMAX	A46X-BF	BEST LIFE	230	1,9	22,23	6.600	AT005867	1	2	3	5						■
T41 PROMAX	A36U-BF	BEST SPEED	230	2,0	22,23	6.600	AT001781	1	2	3	5						■
T41 PROMAX	A30U-BF	BEST SPEED	230	2,5	22,23	6.600	AT001785	1	2	3	5						■
T42 PROMAX	A30U-BF	BEST SPEED	230	2,5	22,23	6.600	AT001790	1	2	3	5						■
T42 PROMAX	A30U-BF	BEST SPEED	230	3,0	22,23	6.600	AT001802	1	2	3	5						■

Stationary rail cutting disc – PROMAX

Ordering example: AT004110

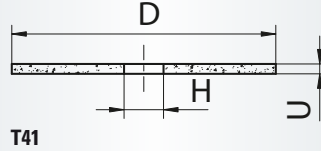

Packing unit:
see page 183
T41 = flat
T42 = depressed centre
 $v_{max.}$: 80 m/s

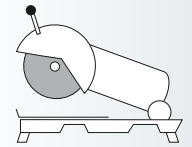

Description	Quality	Variant	Ø D mm	Thickness U mm	Bore H mm	n max. (1/min)	Product-Number	recommended for	
T41 PROMAX	ZA24R-BF	BEST LIFE	350	4,0	22,23	5.400	AT004110	1 2 3 5	NEW
T41 PROMAX	ZA24R-BF	BEST LIFE	350	4,0	25,40	5.400	AT004109	1 2 3 5	NEW
T41 PROMAX	ZA30Q-BF	BEST LIFE	350	4,0	22,23	5.400	AT005828	1 2 3 5	
T41 PROMAX	ZA24R-BF	BEST LIFE	400	4,0	25,40	4.700	AT004116	1 2 3 5	NEW

Cutting discs for metal – PREMIUMFLEX

Ordering example: AT000636

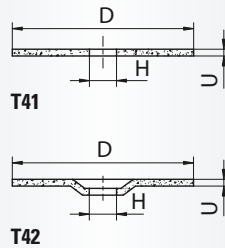

Packing unit:
see page 183
T41 = flat
T42 = depressed centre
 $v_{max.}$: 80 m/s

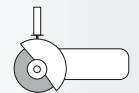

Description	Quality	Variant	Ø D mm	Thickness U mm	Bore H mm	n max. (1/min)	Product-Number	recommended for	
T41 PREMIUMFLEX	A24R-BF	BEST LIFE	100	3,0	16,00	15.300	AT000636	1 2 3 5	NEW
T42 PREMIUMFLEX	A24R-BF	BEST LIFE	100	3,0	16,00	15.300	AT000638	1 2 3 5	
T41 PREMIUMFLEX	A60S-BF	BEST LIFE	115	1,0	22,23	13.300	AT006440	1 2 3 5	
T41 PREMIUMFLEX	A46T-BF	BEST LIFE	115	1,2	22,23	13.300	AT000644	1 2 3 5	
T41 PREMIUMFLEX	A46T-BF	BEST LIFE	115	1,6	22,23	13.300	AT000648	1 2 3 5	
T41 PREMIUMFLEX	A24R-BF	BEST LIFE	115	2,5	22,23	13.300	AT000656	1 2 3 5	
T41 PREMIUMFLEX	A24P-BF	BEST SPEED	115	3,0	22,23	13.300	AT005161	1 2 3 5	
T42 PREMIUMFLEX	A24P-BF	BEST SPEED	115	3,0	22,23	13.300	AT005162	1 2 3 5	
T41 PREMIUMFLEX	A24R-BF	BEST LIFE	115	3,0	22,23	13.300	AT000660	1 2 3 5	
T42 PREMIUMFLEX	A24R-BF	BEST LIFE	115	3,0	22,23	13.300	AT000662	1 2 3 5	
T41 PREMIUMFLEX	A60S-BF	BEST LIFE	125	1,0	22,23	12.200	AT006710	1 2 3 5	
T41 PREMIUMFLEX	A46T-BF	BEST LIFE	125	1,2	22,23	12.200	AT000671	1 2 3 5	
T41 PREMIUMFLEX	A46T-BF	BEST LIFE	125	1,6	22,23	12.200	AT000675	1 2 3 5	
T41 PREMIUMFLEX	A24R-BF	BEST LIFE	125	2,5	22,23	12.200	AT000679	1 2 3 5	
T42 PREMIUMFLEX	A24P-BF	BEST SPEED	125	3,0	22,23	12.200	AT005164	1 2 3 5	
T41 PREMIUMFLEX	A24R-BF	BEST LIFE	125	3,0	22,23	12.200	AT000686	1 2 3 5	
T42 PREMIUMFLEX	A24R-BF	BEST LIFE	125	3,0	22,23	12.200	AT000688	1 2 3 5	
T41 PREMIUMFLEX	A46T-BF	BEST LIFE	150	1,6	22,23	10.200	AT000701	1 2 3 5	NEW
T41 PREMIUMFLEX	A24R-BF	BEST LIFE	150	3,0	22,23	10.200	AT000707	1 2 3 5	

Cutting discs for metal – PREMIUMFLEX

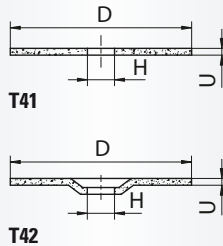
Ordering example: AT000717

Packing unit:

see page 183

T41 = flat

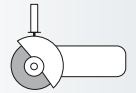
T42 = depressed centre

 $v_{max.}: 80 \text{ m/s}$

Description	Quality	Variant	Ø D mm	Thickness U mm	Bore H mm	n max. (1/min)	Product-Number	recommended for													
T41 PREMIUMFLEX	A46T-BF	BEST LIFE	180	1,6	22,23	8.500	AT000717	1	2	3	5										
T42 PREMIUMFLEX	A24P-BF	BEST SPEED	180	3,0	22,23	8.500	AT001239	1	2	3	5										
T41 PREMIUMFLEX	A24R-BF	BEST LIFE	180	3,0	22,23	8.500	AT000728	1	2	3	5										
T42 PREMIUMFLEX	A24R-BF	BEST LIFE	180	3,0	22,23	8.500	AT000732	1	2	3	5										
T41 PREMIUMFLEX	A46T-BF	BEST LIFE	230	1,9	22,23	6.600	AT000743	1	2	3	5										
T42 PREMIUMFLEX	A46T-BF	BEST LIFE	230	1,9	22,23	6.600	AT000745	1	2	3	5										
T41 PREMIUMFLEX	A36T-BF	BEST LIFE	230	2,0	22,23	6.600	AT000967	1	2	3	5										
T41 PREMIUMFLEX	A24R-BF	BEST LIFE	230	2,5	22,23	6.600	AT000861	1	2	3	5										
T42 PREMIUMFLEX	A24R-BF	BEST LIFE	230	2,5	22,23	6.600	AT004063	1	2	3	5										
T41 PREMIUMFLEX	A24P-BF	BEST SPEED	230	3,0	22,23	6.600	AT005165	1	2	3	5										
T42 PREMIUMFLEX	A24P-BF	BEST SPEED	230	3,0	22,23	6.600	AT005166	1	2	3	5										
T41 PREMIUMFLEX	A24R-BF	BEST LIFE	230	3,0	22,23	6.600	AT000750	1	2	3	5										
T42 PREMIUMFLEX	A24R-BF	BEST LIFE	230	3,0	22,23	6.600	AT000754	1	2	3	5										

Cutting discs for metal – BASE-X

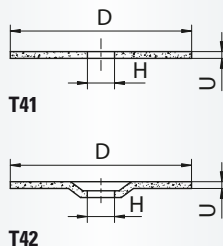
Ordering example: A3890101150122001

Packing unit:

see page 183

T41 = flat

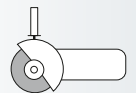
T42 = depressed centre

 $v_{max.}: 80 \text{ m/s}$

Description	Quality	Ø D mm	Thickness U mm	Bore H mm	n max. (1/min)	Product-Number	recommended for														
T41 BASE-X	A60T-BF	115	1,0	22,23	13.300	A3890101150122001	1	2	3	5											
T41 BASE-X	A30R-BF	115	3,0	22,23	13.300	A3890101150322002	1	2	3	5											
T42 BASE-X	A30R-BF	115	3,0	22,23	13.300	A3890101150322001	1	2	3	5											
T41 BASE-X	A60T-BF	125	1,0	22,23	12.200	A3890101250122001	1	2	3	5											
T41 BASE-X	A30R-BF	125	3,0	22,23	12.200	A3890101250322002	1	2	3	5											
T42 BASE-X	A30R-BF	125	3,0	22,23	12.200	A3890101250322001	1	2	3	5											
T41 BASE-X	A30R-BF	180	3,0	22,23	8.500	A3890101800322002	1	2	3	5											
T42 BASE-X	A30R-BF	180	3,0	22,23	8.500	A3890101800322001	1	2	3	5											
T41 BASE-X	A30R-BF	230	3,0	22,23	6.600	A3890102300322002	1	2	3	5											
T42 BASE-X	A30R-BF	230	3,0	22,23	6.600	A3890102300322001	1	2	3	5											

Cutting discs for non-ferrous metals – PROMAX

Ordering example: AT000920

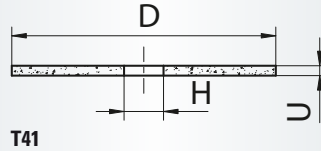

Packing unit:

see page 183

T41 = flat

T42 = depressed centre

v_{max.}: 80 m/s

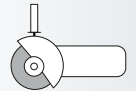

Description	Quality	Variant	Ø D mm	Thickness U mm	Bore H mm	n max. (1/min)	Product-Number	recommended for	
T41 PROMAX	A60N-BF ALU	BEST LIFE	115	1,0	22,23	13.300	AT000920	① ② ③ ④ ⑤ ⑥ ⑦	■
T41 PROMAX	A46N-BF ALU	BEST LIFE	115	1,6	22,23	13.300	AT004776	① ② ③ ④ ⑤ ⑥ ⑦	■
T41 PROMAX	A36N-BF ALU	BEST LIFE	115	2,5	22,23	13.300	AT001664	① ② ③ ④ ⑤ ⑥ ⑦	■
T41 PROMAX	A60N-BF ALU	BEST LIFE	125	1,0	22,23	12.200	AT000950	① ② ③ ④ ⑤ ⑥ ⑦	■
T41 PROMAX	A46N-BF ALU	BEST LIFE	125	1,6	22,23	12.200	AT004788	① ② ③ ④ ⑤ ⑥ ⑦	■
T41 PROMAX	A36N-BF ALU	BEST LIFE	125	2,5	22,23	12.200	AT001694	① ② ③ ④ ⑤ ⑥ ⑦	■
T41 PROMAX	A46N-BF ALU	BEST LIFE	150	1,6	22,23	10.200	AT001000	① ② ③ ④ ⑤ ⑥ ⑦	■
T41 PROMAX	A36N-BF ALU	BEST LIFE	150	2,5	22,23	10.200	AT001723	① ② ③ ④ ⑤ ⑥ ⑦	■
T41 PROMAX	A46N-BF ALU	BEST LIFE	180	1,6	22,23	8.500	AT000985	① ② ③ ④ ⑤ ⑥ ⑦	■
T41 PROMAX	A36N-BF ALU	BEST LIFE	180	2,5	22,23	8.500	AT001755	① ② ③ ④ ⑤ ⑥ ⑦	■
T41 PROMAX	A46N-BF ALU	BEST LIFE	230	1,9	22,23	6.600	AT002613	① ② ③ ④ ⑤ ⑥ ⑦	■
T41 PROMAX	A36N-BF ALU	BEST LIFE	230	2,5	22,23	6.600	AT001789	① ② ③ ④ ⑤ ⑥ ⑦	■
T41 PROMAX	A36N-BF ALU	BEST LIFE	230	3,0	22,23	6.600	AT003459	① ② ③ ④ ⑤ ⑥ ⑦	■

NEW

NEW

Cutting discs for stone, concrete and cast iron – PROMAX

Ordering example: AT003017

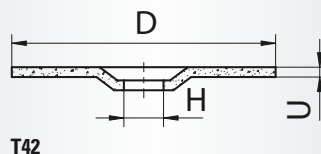

Packing unit:

see page 183

T41 = flat

T42 = depressed centre

v_{max.}: 80 m/s

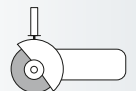

Description	Quality	Variant	Ø D mm	Thickness U mm	Bore H mm	n max. (1/min)	Product-Number	recommended for	
T42 PROMAX	C30X-BF	BEST LIFE	230	3,0	22,23	6.600	AT003017	⑤ ⑩ ⑪ ⑫	■

Cutting discs for stone, concrete and cast iron – PREMIUMFLEX

Ordering example: AT000637

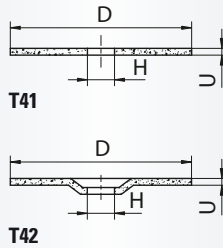

Packing unit:

see page 183
 T41 = flat
 T42 = depressed centre
 $v_{max.}$: 80 m/s

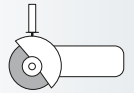

Description	Quality	Variant	Ø D mm	Thickness U mm	Bore H mm	n max. (1/min)	Product-Number	recommended for	
T41 PREMIUMFLEX	C30S-BF	BEST LIFE	100	3,0	16,00	15.300	AT000637	5 10 11 12	■
T42 PREMIUMFLEX	C30S-BF	BEST LIFE	100	3,0	16,00	15.300	AT000639	5 10 11 12	■
T41 PREMIUMFLEX	C46R-BF	BEST LIFE	115	1,6	22,23	13.300	AT002317	5 10 11 12	■
T42 PREMIUMFLEX	C46R-BF	BEST LIFE	115	1,6	22,23	13.300	AT002318	5 10 11 12	■
T41 PREMIUMFLEX	C30S-BF	BEST LIFE	115	3,0	22,23	13.300	AT000661	5 10 11 12	■
T42 PREMIUMFLEX	C30S-BF	BEST LIFE	115	3,0	22,23	13.300	AT000664	5 10 11 12	■
T41 PREMIUMFLEX	C46R-BF	BEST LIFE	125	1,6	22,23	12.200	AT002377	5 10 11 12	■
T41 PREMIUMFLEX	C30S-BF	BEST LIFE	125	3,0	22,23	12.200	AT000687	5 10 11 12	■
T42 PREMIUMFLEX	C30S-BF	BEST LIFE	125	3,0	22,23	12.200	AT000689	5 10 11 12	■
T41 PREMIUMFLEX	C46R-BF	BEST LIFE	180	1,6	22,23	8.500	AT002381	5 10 11 12	■
T41 PREMIUMFLEX	C30S-BF	BEST LIFE	180	3,0	22,23	8.500	AT000730	5 10 11 12	■
T42 PREMIUMFLEX	C30S-BF	BEST LIFE	180	3,0	22,23	8.500	AT000734	5 10 11 12	■
T41 PREMIUMFLEX	C46R-BF	BEST LIFE	230	1,9	22,23	6.600	AT001372	5 10 11 12	■
T42 PREMIUMFLEX	C46R-BF	BEST LIFE	230	1,9	22,23	6.600	AT001373	5 10 11 12	■
T41 PREMIUMFLEX	C30S-BF	BEST LIFE	230	3,0	22,23	6.600	AT000752	5 10 11 12	■
T42 PREMIUMFLEX	C30S-BF	BEST LIFE	230	3,0	22,23	6.600	AT000756	5 10 11 12	■
T42 PREMIUMFLEX	AC24R-BF	BEST LIFE	230	3,0	22,23	6.600	AT011009	5 10 11 12	■

Stationary cutting discs for stainless steel – PREMIUMFLEX

Ordering example: AT010003

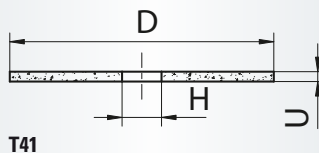

Packing unit:

see page 183
 T41 = flat
 T42 = depressed centre
 Iron, sulphur and chlorine < 0,1%
 $v_{max.}$: 80 m/s

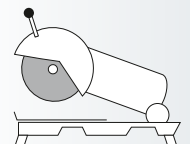

Description	Quality	Variant	Ø D mm	Thickness U mm	Bore H mm	n max. (1/min)	Product-Number	recommended for	
T41 PREMIUMFLEX	A30S-BF INOX	BEST LIFE	300	3,5	32,00	5.100	AT010003	1 2 3 4 5 6 7	■
T41 PREMIUMFLEX	A36S-BF INOX	BEST LIFE	350	2,6	25,40	4.400	AT020208	1 2 3 4 5 6 7	■
T41 PREMIUMFLEX	A30S-BF INOX	BEST LIFE	350	3,5	32,00	4.400	AT010011	1 2 3 4 5 6 7	■
T41 PREMIUMFLEX	A30S-BF INOX	BEST LIFE	400	4,0	25,40	3.800	AT010014	1 2 3 4 5 6 7	■
T41 PREMIUMFLEX	A30S-BF INOX	BEST LIFE	400	4,0	32,00	3.800	AT010015	1 2 3 4 5 6 7	■
T41 PREMIUMFLEX	A30S-BF INOX	BEST LIFE	400	4,0	40,00	3.800	AT010016	1 2 3 4 5 6 7	■

Cutting discs for metal – PREMIUMFLEX

Ordering example: AT010052

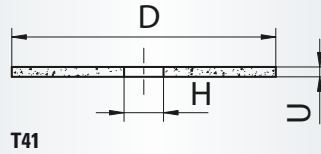

Packing unit:
see page 183

T41 = flat
T42 = depressed centre
 $v_{max.}$: 100 m/s

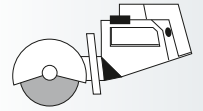

Description	Quality	Variant	Ø D mm	Thickness U mm	Bore H mm	n max. (1/min)	Product-Number	recommended for	
T41 PREMIUMFLEX	A24R-BF	BEST LIFE	300	4,0	20,00	6.400	AT010052	1 2 3 5	■
T41 PREMIUMFLEX	A24R-BF	BEST LIFE	350	4,0	20,00	5.400	AT010055	1 2 3 5	■
T41 PREMIUMFLEX	A24R-BF	BEST LIFE	350	4,0	25,40	5.400	AT010057	1 2 3 5	■
T41 PREMIUMFLEX	A24R-BF	BEST LIFE	400	4,0	22,23	4.700	AT002844	1 2 3 5	■

Stationary cutting discs for metal – PREMIUMFLEX

Ordering example: AT010028

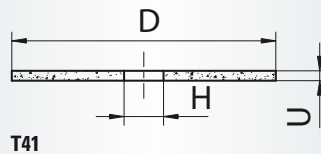

Packing unit:
see page 183

T41 = flat
T42 = depressed centre
 $v_{max.}$: 80 m/s or 100 m/s

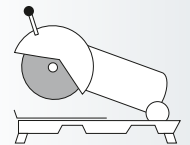

Description	Quality	Variant	Ø D mm	Thickness U mm	Bore H mm	n max. (1/min)	Product-Number	recommended for	
T41 PREMIUMFLEX	A36S-BF	BEST LIFE	300	2,6	25,40	5.100 / 80 m/s	AT010028	1 2 3 5	■
T41 PREMIUMFLEX	A30T-BF	BEST LIFE	300	3,5	22,23	6.400 / 100 m/s	AT001774	1 2 3 5	■
T41 PREMIUMFLEX	A30T-BF	BEST LIFE	300	3,5	25,40	6.400 / 100 m/s	AT001776	1 2 3 5	■
T41 PREMIUMFLEX	A30T-BF	BEST LIFE	300	3,5	32,00	6.400 / 100 m/s	AT010020	1 2 3 5	■
T41 PREMIUMFLEX	A36S-BF	BEST LIFE	350	2,6	25,40	4.400 / 80 m/s	AT010029	1 2 3 5	■
T41 PREMIUMFLEX	A30T-BF	BEST LIFE	350	3,5	25,40	5.400 / 100 m/s	AT010022	1 2 3 5	■
T41 PREMIUMFLEX	A30T-BF	BEST LIFE	350	3,5	32,00	5.400 / 100 m/s	AT010023	1 2 3 5	■
T41 PREMIUMFLEX	A36S-BF	BEST LIFE	400	3,2	25,40	3.800 / 80 m/s	AT010030	1 2 3 5	■
T41 PREMIUMFLEX	A30T-BF	BEST LIFE	400	4,0	32,00	4.700 / 100 m/s	AT010026	1 2 3 5	■

Cutting discs for stone, concrete and cast iron – PREMIUMFLEX

Ordering example: AT010060



T41

Packing unit:

see page 183

T41 = flat

T42 = depressed centre

v_{max.}: 80 m/s

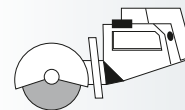

Description	Quality	Variant	Ø D mm	Thickness U mm	Bore H mm	n max. (1/min)	Product-Number	recommended for	
T41 PREMIUMFLEX	C24R-BF	BEST LIFE	300	4,0	25,40	6.400	AT010060	5 10 11 12	■
T41 PREMIUMFLEX	AC24R-BF	BEST LIFE	300	4,0	20,00	6.400	AT000788	5 10 11 12	■
T41 PREMIUMFLEX	C24R-BF	BEST LIFE	350	4,0	20,00	5.400	AT010061	5 10 11 12	■
T41 PREMIUMFLEX	AC24R-BF	BEST LIFE	350	4,0	20,00	5.400	AT000816	5 10 11 12	■

Application example Cutting disc for stone, concrete and cast iron



Small cutting discs for stainless steel – PROGRESS

Ordering example: AT007201

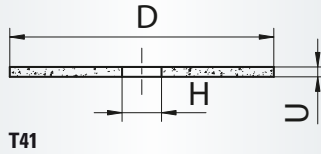

Packing unit:
see page 183

T41 = flat

Iron, sulphur and chlorine < 0,1%

v_{max}: 80 m/s

See page 411 for
suitable mounting arbors. .



Description	Quality	Variant	Ø D mm	Thickness U mm	Bore H mm	n max. (1/min)	Product-Number	recommended for		
T41 PROGRESS	A60Z-BF INOX	HCS	50	1,0	10,00	30.500	AT007201	1 2 3 4 5 6 7	■	NEW
T41 PROGRESS	A60Z-BF INOX	HCS	76	1,0	10,00	20.100	AT007200	1 2 3 4 5 6 7	■	NEW

Small cutting discs for stainless steel – PREMIUMFLEX

Ordering example: AT501006

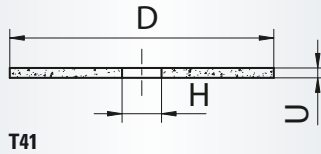

Packing unit:
see page 183

T41 = flat

Iron, sulphur and chlorine < 0,1%

v_{max}: 80 m/s

See page 411 for
suitable mounting arbors.



Description	Quality	Variant	Ø D mm	Thickness U mm	Bore H mm	n max. (1/min)	Product-Number	recommended for		
T41 PREMIUMFLEX	A46S-BF INOX	BEST LIFE	50	1,0	6,00	30.500	AT501006	1 2 3 4 5 6 7	■	
T41 PREMIUMFLEX	A46S-BF INOX	BEST LIFE	50	1,0	10,00	30.500	AT501010	1 2 3 4 5 6 7	■	
T41 PREMIUMFLEX	A46S-BF INOX	BEST LIFE	50	2,0	6,00	30.500	AT502006	1 2 3 4 5 6 7	■	
T41 PREMIUMFLEX	A46S-BF INOX	BEST LIFE	76	1,0	10,00	20.100	AT761010	1 2 3 4 5 6 7	■	
T41 PREMIUMFLEX	A46S-BF INOX	BEST LIFE	76	2,0	6,00	20.100	AT762006	1 2 3 4 5 6 7	■	
T41 PREMIUMFLEX	A46S-BF INOX	BEST LIFE	76	2,0	10,00	20.100	AT762010	1 2 3 4 5 6 7	■	
T41 PREMIUMFLEX	A46S-BF INOX	BEST LIFE	76	3,0	10,00	20.100	AT763010	1 2 3 4 5 6 7	■	

Always the right tool

For Highest Standards in Surface Finishing!



Grinding discs

- 198** Qualities and areas of application

- 200** Free-hand grinding discs for angle grinders

- 207** Small grinding discs

- 208** Cup Wheels







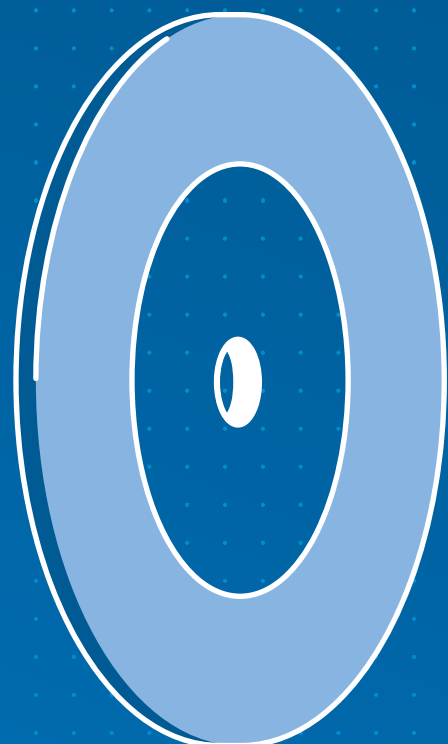



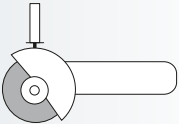



Product line marking

Product lines are labelled in the table header with the appropriate tabs. Further information on page **14** and **15**.



Grinding discs

Type	Product line	Material			
		INOX/Steel	Steel	Aluminium	Stone/Cast material
Free-hand grinding discs for angle grinders 	High Performance				
	PROGRESS	Page 200-201 	Page 204 		
	Industry				
	PROMAX	Page 200-202 	Page 203-204 	Page 206 	Page 206-207 
	Base				
	PREMIUMFLEX BASE-X	Page 203 	Page 205 		Page 207 
Small grinding discs 	Base				
	PREMIUMFLEX BASE-X	Page 207 			



Peter Smith
Sales Department



Always the right tool

Cutting and grinding discs „PROGRESS“:
Please convince yourself of our top quality products with an **optimal tool life** to cost ratio!

www.lukas-erzett.com

HighCut-Solution – HCS

optimum cutting performance and service life

low odour and dust levels

optimised for top performance



- maximum service life and cutting performance due to innovative bonding technology
- high cutting speed at low cutting temperature
- low odour and dust levels during daily usage
- ergonomic work position and maximum durability without use of excessive force
- maximum shelf life with high levels of stability with regard to quality thanks to top quality raw materials
- energy optimised for your high performance angle grinders
- environmentally friendly manufacturing process, made in Germany using up-to-date production processes and optimised formulations
- perfect for a wide variety of Inox and steel materials
- precise cutting

durable stable with regard to quality

BEST SPEED and BEST LIFE – it's your choice!

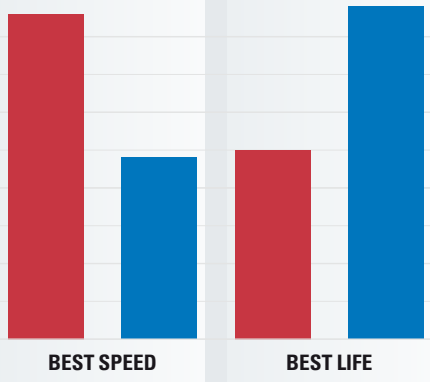

Our tools are consistently designed for high performance. But as application parameters and expectations of our cutting and grinding discs can differ considerably, we offer you variants:

BEST SPEED is the right choice for all those who want quick results. Shorter grinding times ensure that work progresses with speed.

BEST LIFE ensures a long service life per tool and optimizes tool changing intervals

■ Cutting speed
 ■ Service life

Packing units

Diameter (mm)	Disc width (mm)	Packing units
76	all	50 pieces
100–230	3	25 pieces
	4	20 pieces
	≥ 6	10 pieces

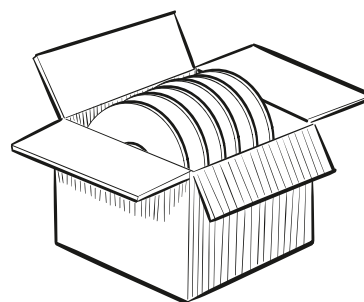



Cutting and grinding without tool change.

Safe. Precise. Perfect.

ROTLUFF

High Performance

Grinding and cutting disc to machine stainless steel – PROGRESS COOL JOBBER

Ordering example: AS015675

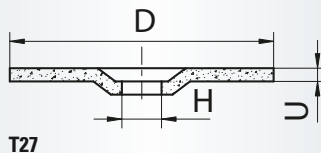

Packing unit:
see page 199

T27 = depressed centre
Iron, sulphur and chlorine < 0,1%
v_{max.}: 80 m/s

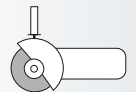

Description	Quality	Variant	Ø D mm	Thickness U mm	Bore H mm	n max. (1/min)	Product-Number	recommended for
NEW T27 PROGRESS	A36V-BF INOX COOL JOBBER	HCS	115	3,0	22,23	13.300	AS015675	1 2 3 4 6
NEW T27 PROGRESS	A36V-BF INOX COOL JOBBER	HCS	125	3,0	22,23	12.200	AS015676	1 2 3 4 6
NEW T27 PROGRESS	A36V-BF INOX COOL JOBBER	HCS	150	3,0	22,23	10.200	AS015677	1 2 3 4 6
NEW T27 PROGRESS	A36V-BF INOX COOL JOBBER	HCS	180	3,0	22,23	8.500	AS015678	1 2 3 4 6
NEW T27 PROGRESS	A36V-BF INOX COOL JOBBER	HCS	230	3,0	22,23	6.600	AS015684	1 2 3 4 6

• Excellent grinding performance, thanks to the pimples in its structure

ROTLUFF

Industry

Grinding and cutting disc to machine stainless steel – PROMAX COOL JOBBER

Ordering example: AS005674

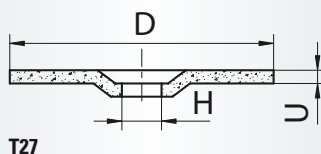

Packing unit:
see page 199

T27 = depressed centre
Iron, sulphur and chlorine < 0,1%
v_{max.}: 80 m/s

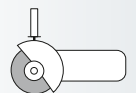

Description	Quality	Variant	Ø D mm	Thickness U mm	Bore H mm	n max. (1/min)	Product-Number	recommended for
NEW T27 PROMAX	A24S-BF INOX COOL JOBBER	BEST SPEED	115	3,0	22,23	13.300	AS005674	1 2 3 4 6
T27 PROMAX	A24S-BF INOX COOL JOBBER	BEST SPEED	125	3,0	22,23	12.200	AS005705	1 2 3 4 6
NEW T27 PROMAX	A24S-BF INOX COOL JOBBER	BEST SPEED	150	3,0	22,23	10.200	AS005706	1 2 3 4 6
NEW T27 PROMAX	A24S-BF INOX COOL JOBBER	BEST SPEED	180	3,0	22,23	8.500	AS005766	1 2 3 4 6
NEW T27 PROMAX	A24S-BF INOX COOL JOBBER	BEST SPEED	230	3,2	22,23	6.600	AS005785	1 2 3 4 6

• Excellent grinding performance, thanks to the pimples in its structure

Grinding and cutting disc to machine stainless steel – PROMAX

Ordering example: AS001674



2-in-1

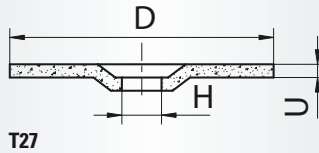

T27

Packing unit:

see page 199

T27 = depressed centre

Iron, sulphur and chlorine < 0,1%

v_{max}: 80 m/s

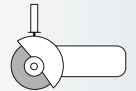

Description	Quality	Variant	Ø D mm	Thickness U mm	Bore H mm	n max. (1/min)	Product-Number	recommended for									
T27 PROMAX	A24V-BF INOX	BEST SPEED	115	4,0	22,23	13.300	AS001674	1	2	3	4	6					■
T27 PROMAX	A24V-BF INOX	BEST SPEED	125	4,0	22,23	12.200	AS001705	1	2	3	4	6					■
T27 PROMAX	A24V-BF INOX	BEST SPEED	150	4,0	22,23	10.200	AS001521	1	2	3	4	6					■
T27 PROMAX	A24V-BF INOX	BEST SPEED	180	4,0	22,23	8.500	AS001766	1	2	3	4	6					■
T27 PROMAX	A24V-BF INOX	BEST SPEED	230	4,0	22,23	6.600	AS001805	1	2	3	4	6					■

Grinding disc to machine stainless steel – PROGRESS

Ordering example: AS013491

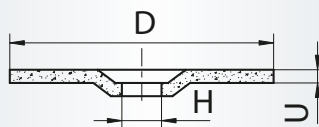

T27

Packing unit:

see page 199

T27 = depressed centre

Iron, sulphur and chlorine < 0,1%

v_{max}: 80 m/s

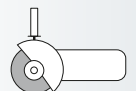

Description	Quality	Variant	Ø D mm	Thickness U mm	Bore H mm	n max. (1/min)	Product-Number	recommended for										
T27 PROGRESS	A24U-BF INOX	HCS	115	7,0	22,23	13.300	AS013491	1	2	3	4	6					■	NEW
T27 PROGRESS	A24U-BF INOX	HCS	125	7,0	22,23	12.200	AS013492	1	2	3	4	6					■	NEW
T27 PROGRESS	A24U-BF INOX	HCS	150	7,0	22,23	10.200	AS013410	1	2	3	4	6					■	NEW
T27 PROGRESS	A24U-BF INOX	HCS	180	7,0	22,23	8.500	AS013494	1	2	3	4	6					■	NEW
T27 PROGRESS	A24U-BF INOX	HCS	230	7,0	22,23	6.600	AS013496	1	2	3	4	6					■	NEW

- Excellent grinding performance, thanks to the pimples in its structure

Grinding discs for stainless steel – PROMAX

Ordering example: AS003392

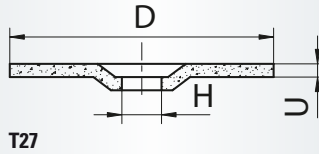

Packing unit:

see page 199

T27 = depressed centre

Iron, sulphur and chlorine < 0,1%

v_{max.}: 80 m/s

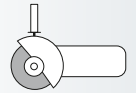

Description	Quality	Variant	Ø D mm	Thickness U mm	Bore H mm	n max. (1/min)	Product-Number	recommended for
NEW T27 PROMAX	A24S-BF INOX	BEST SPEED	115	7,0	22,23	13.300	AS003392	1 2 3 4 6
T27 PROMAX	A24S-BF INOX	BEST SPEED	125	7,0	22,23	12.200	AS003393	1 2 3 4 6
NEW T27 PROMAX	A24S-BF INOX	BEST SPEED	150	7,0	22,23	10.200	AS003788	1 2 3 4 6
NEW T27 PROMAX	A24S-BF INOX	BEST SPEED	180	7,0	22,23	8.500	AS003394	1 2 3 4 6
NEW T27 PROMAX	A24S-BF INOX	BEST SPEED	230	7,0	22,23	6.600	AS003396	1 2 3 4 6

• Excellent grinding performance, thanks to the pimples in its structure

Grinding discs for stainless steel – PROMAX

Ordering example: AS003100

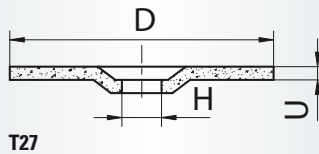

Packing unit:

see page 199

T27 = depressed centre

Iron, sulphur and chlorine < 0,1%

v_{max.}: 80 m/s

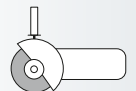

Description	Quality	Variant	Ø D mm	Thickness U mm	Bore H mm	n max. (1/min)	Product-Number	recommended for
T27 PROMAX	A24X-BF INOX	BEST LIFE	115	7,0	22,23	13.300	AS003100	1 2 3 4 6
T27 PROMAX	A24V-BF INOX	BEST SPEED	125	7,0	22,23	12.200	AS001709	1 2 3 4 6
T27 PROMAX	A24X-BF INOX	BEST LIFE	125	7,0	22,23	12.200	AS003101	1 2 3 4 6
T27 PROMAX	A24X-BF INOX	BEST LIFE	180	7,0	22,23	8.500	AS003103	1 2 3 4 6
T27 PROMAX	A24V-BF INOX	BEST SPEED	230	7,0	22,23	6.600	AS001810	1 2 3 4 6
T27 PROMAX	A24X-BF INOX	BEST LIFE	230	7,0	22,23	6.600	AS003104	1 2 3 4 6

Grinding discs for stainless steel – PREMIUMFLEX

Ordering example: AS002037

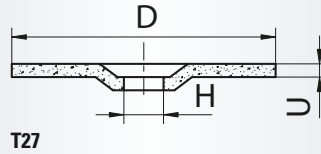

Packing unit:
see page 199
T27 = depressed centre
Iron, sulphur and chlorine < 0,1%
v_{max.}: 80 m/s

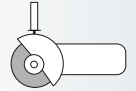

Description	Quality	Variant	Ø D mm	Thickness U mm	Bore H mm	n max. (1/min)	Product-Number	recommended for	
T27 PREMIUMFLEX	A24/30S-BF INOX	BEST LIFE	100	6,0	16,00	15.300	AS002037	1 2 3 4	■
T27 PREMIUMFLEX	A24/30S-BF INOX	BEST LIFE	115	6,4	22,23	13.300	AS000105	1 2 3 4	■
T27 PREMIUMFLEX	A24/30S-BF INOX	BEST LIFE	125	4,0	22,23	12.200	AS003106	1 2 3 4	■
T27 PREMIUMFLEX	A24/30Q-BF INOX	BEST SPEED	125	6,0	22,23	12.200	AS001603	1 2 3 4	■
T27 PREMIUMFLEX	A24P-BF INOX	BEST SPEED	125	6,0	22,23	12.200	AS000694	1 2 3 4	■
T27 PREMIUMFLEX	A24/30S-BF INOX	BEST LIFE	125	6,4	22,23	12.200	AS000106	1 2 3 4	■
T27 PREMIUMFLEX	A24/30S-BF INOX	BEST LIFE	150	6,4	22,23	10.200	AS000107	1 2 3 4	■
T27 PREMIUMFLEX	A24/30S-BF INOX	BEST LIFE	180	6,4	22,23	8.500	AS000108	1 2 3 4	■
T27 PREMIUMFLEX	A24/30Q-BF INOX	BEST SPEED	180	8,0	22,23	8.500	AS001606	1 2 3 4	■
T27 PREMIUMFLEX	A24/30S-BF INOX	BEST LIFE	180	8,0	22,23	8.500	AS002108	1 2 3 4	■
T27 PREMIUMFLEX	A24/30S-BF INOX	BEST LIFE	230	6,4	22,23	6.600	AS000109	1 2 3 4	■
T27 PREMIUMFLEX	A24P-BF INOX	BEST SPEED	230	6,5	22,23	6.600	AS000763	1 2 3 4	■

Grinding and cutting disc for steel – PROMAX

Ordering example: AS001675

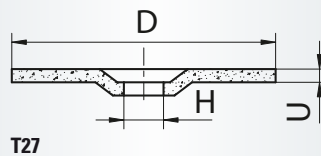

Packing unit:
see page 199
T27 = depressed centre
v_{max.}: 80 m/s

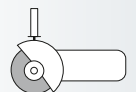

Description	Quality	Variant	Ø D mm	Thickness U mm	Bore H mm	n max. (1/min)	Product-Number	recommended for		
T27 PROMAX	A24T-BF	BEST LIFE	115	4,0	22,23	13.300	AS001675	1 2 3	■	NEW
T27 PROMAX	A24T-BF	BEST LIFE	125	4,0	22,23	12.200	AS001706	1 2 3	■	
T27 PROMAX	A24T-BF	BEST LIFE	150	4,0	22,23	10.200	AS001732	1 2 3	■	NEW
T27 PROMAX	A24T-BF	BEST LIFE	180	4,0	22,23	8.500	AS001767	1 2 3	■	NEW
T27 PROMAX	A24T-BF	BEST LIFE	230	4,0	22,23	6.600	AS001806	1 2 3	■	NEW

Grinding disc for steel – PROGRESS

Ordering example: AS012451

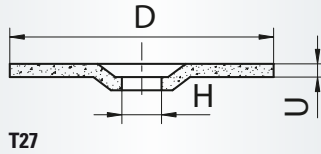

Packing unit:
see page 199
T27 = depressed centre
V_{max.}: 80 m/s

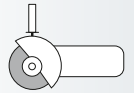

Description	Quality	Variant	Ø D mm	Thickness U mm	Bore H mm	n max. (1/min)	Product-Number	recommended for	
NEW T27 PROGRESS	A24X-BF	HCS	115	7,0	22,23	13.300	AS012451	1 2 3	■
NEW T27 PROGRESS	A24X-BF	HCS	125	7,0	22,23	12.200	AS012453	1 2 3	■
NEW T27 PROGRESS	A24X-BF	HCS	150	7,0	22,23	10.200	AS012458	1 2 3	■
NEW T27 PROGRESS	A24X-BF	HCS	180	7,0	22,23	8.500	AS012466	1 2 3	■
NEW T27 PROGRESS	A24X-BF	HCS	230	7,0	22,23	6.600	AS012468	1 2 3	■

Grinding disc for steel – PROMAX

Ordering example: AS001679

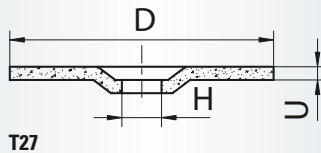

Packing unit:
see page 199
T27 = depressed centre
V_{max.}: 80 m/s

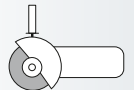

Description	Quality	Variant	Ø D mm	Thickness U mm	Bore H mm	n max. (1/min)	Product-Number	recommended for	
T27 PROMAX	A24/30T-BF	BEST SPEED	115	7,0	22,23	13.300	AS001679	1 2 3 5	■
T27 PROMAX	A24/30T-BF	BEST SPEED	125	7,0	22,23	12.200	AS001710	1 2 3 5	■
NEW T27 PROMAX	A24/30T-BF	BEST SPEED	150	7,0	22,23	10.200	AS001736	1 2 3 5	■
T27 PROMAX	A24/30T-BF	BEST SPEED	180	7,0	22,23	8.500	AS001772	1 2 3 5	■
T27 PROMAX	A24/30T-BF	BEST SPEED	230	7,0	22,23	6.600	AS001811	1 2 3 5	■

Grinding disc for steel – PREMIUMFLEX

Ordering example: AS000642

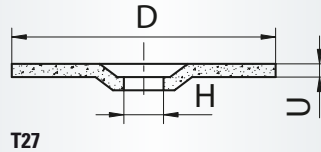

Packing unit:
see page 199
T27 = depressed centre
V_{max}: 80 m/s

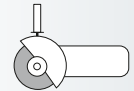

Description	Quality	Variant	Ø D mm	Thickness U mm	Bore H mm	n max. (1/min)	Product-Number	recommended for	
T27 PREMIUMFLEX	A24/30S-BF	BEST LIFE	100	6,0	16,00	15.300	AS000642	1 2 3	■
T27 PREMIUMFLEX	A24/30S-BF	BEST LIFE	115	6,0	22,23	13.300	AS000667	1 2 3	■
T27 PREMIUMFLEX	A24/30P-BF	BEST SPEED	115	6,0	22,23	13.300	AS000992	1 2 3 5	■
T27 PREMIUMFLEX	A24/30S-BF	BEST LIFE	125	4,0	22,23	12.200	AS000690	1 2 3	■
T27 PREMIUMFLEX	A24/30S-BF	BEST LIFE	125	6,0	22,23	12.200	AS000692	1 2 3	■
T27 PREMIUMFLEX	A24/30P-BF	BEST SPEED	125	6,0	22,23	12.200	AS000999	1 2 3 5	■
T27 PREMIUMFLEX	A24/30S-BF	BEST LIFE	125	8,0	22,23	12.200	AS000696	1 2 3	■
T27 PREMIUMFLEX	A24/30S-BF	BEST LIFE	150	4,0	22,23	10.200	AS002920	1 2 3	■
T27 PREMIUMFLEX	A24/30P-BF	BEST SPEED	150	6,0	22,23	10.200	AS003712	1 2 3 5	■
T27 PREMIUMFLEX	A24/30S-BF	BEST LIFE	150	6,0	22,23	10.200	AS000712	1 2 3	■
T27 PREMIUMFLEX	A24/30P-BF	BEST SPEED	180	6,5	22,23	8.500	AS001009	1 2 3 5	■
T27 PREMIUMFLEX	A24/30S-BF	BEST LIFE	180	6,5	22,23	8.500	AS000737	1 2 3	■
T27 PREMIUMFLEX	A24/30S-BF	BEST LIFE	180	8,0	22,23	8.500	AS000740	1 2 3	■
T27 PREMIUMFLEX	A24/30S-BF	BEST LIFE	230	6,5	22,23	6.600	AS000762	1 2 3	■
T27 PREMIUMFLEX	A24/30P-BF	BEST SPEED	230	6,5	22,23	6.600	AS001017	1 2 3 5	■
T27 PREMIUMFLEX	A24/30S-BF	BEST LIFE	230	8,0	22,23	6.600	AS000767	1 2 3	■



Grinding disc for steel – BASE-X

Ordering example: A3891101150622001

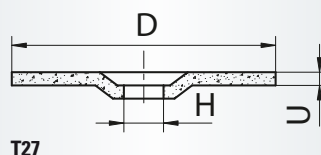

Packing unit:
see page 199
T27 = depressed centre
V_{max}: 80 m/s

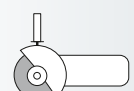

Description	Quality	Ø D mm	Thickness U mm	Bore H mm	n max. (1/min)	Product-Number	recommended for	
T27 BASE-X	A24R-BF	115	6,0	22,23	13.300	A3891101150622001	1 2 3	■
T27 BASE-X	A24R-BF	125	6,0	22,23	12.200	A3891101250622001	1 2 3	■
T27 BASE-X	A24R-BF	180	6,0	22,23	8.500	A3891101800622001	1 2 3	■
T27 BASE-X	A24R-BF	230	6,0	22,23	6.600	A3891102300622001	1 2 3	■

Grinding discs for non-ferrous metals – PROMAX

Ordering example: AS001677

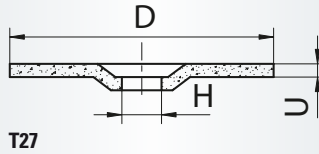

Packing unit:

see page 199

T27 = depressed centre

$v_{max.}$: 80 m/s

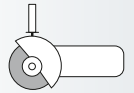

Description	Quality	Variant	Ø D mm	Thickness U mm	Bore H mm	n max. (1/min)	Product-Number	recommended for	
T27 PROMAX	A36N-BF ALU	BEST LIFE	115	7,0	22,23	13.300	AS001677	① ② ③ ④ ⑥	■
T27 PROMAX	A36N-BF ALU	BEST LIFE	125	7,0	22,23	12.200	AS001708	① ② ③ ④ ⑥	■
T27 PROMAX	A36N-BF ALU	BEST LIFE	180	7,0	22,23	8.500	AS001770	① ② ③ ④ ⑥	■
T27 PROMAX	A36N-BF ALU	BEST LIFE	230	7,0	22,23	6.600	AS001809	① ② ③ ④ ⑥	■

Grinding discs for cast iron – PROMAX

Ordering example: AS001773

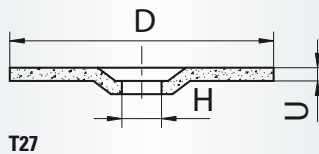

Packing unit:

see page 199

T27 = depressed centre

$v_{max.}$: 80 m/s

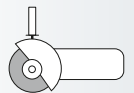

Description	Quality	Variant	Ø D mm	Thickness U mm	Bore H mm	n max. (1/min)	Product-Number	recommended for	
T27 PROMAX	ZA24R-BF	BEST LIFE	180	7,0	22,23	8.500	AS001773	① ② ③ ⑤	■
NEW T27 PROMAX	ZAC24R-BF	BEST LIFE	230	4,8	22,23	6.600	AS000499	⑤	■
T27 PROMAX	ZA24R-BF	BEST LIFE	230	7,0	22,23	6.600	AS001812	① ② ③ ⑤	■

ROTTLUFF

Industry

Grinding discs for stone and cast iron – PROMAX

Ordering example: AS000320

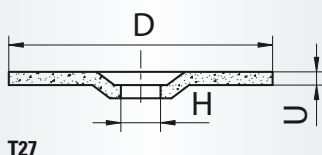

Packing unit:

see page 199

T27 = depressed centre

$v_{max.}$: 80 m/s

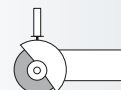

Description	Quality	Variant	Ø D mm	Thickness U mm	Bore H mm	n max. (1/min)	Product-Number	recommended for														
T27 PROMAX	C24R-BF	BEST LIFE	180	7,0	22,23	8.500	AS000320												5	7	■	NEW
T27 PROMAX	C24R-BF	BEST LIFE	230	7,0	22,23	6.600	AS000325												5	7	■	NEW

ROTTLUFF

Base

Grinding discs for stone and cast iron – PREMIUMFLEX

Ordering example: AS001617

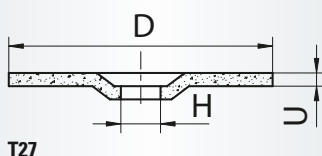

Packing unit:

see page 199

T27 = depressed centre

$v_{max.}$: 80 m/s

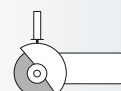

Description	Quality	Variant	Ø D mm	Thickness U mm	Bore H mm	n max. (1/min)	Product-Number	recommended for													
T27 PREMIUMFLEX	C24N-BF	BEST LIFE	115	6,0	22,23	13.300	AS001617	5	10	11	12										■
T27 PREMIUMFLEX	C24N-BF	BEST LIFE	125	6,0	22,23	12.200	AS001618	5	10	11	12										■
T27 PREMIUMFLEX	AC24S-BF	BEST LIFE	180	8,0	22,23	8.500	AS001598	5	10	11	12										■
T27 PREMIUMFLEX	AC24S-BF	BEST LIFE	230	6,8	22,23	6.600	AS001599	5	10	11	12										■
T27 PREMIUMFLEX	C24N-BF	BEST LIFE	230	6,8	22,23	6.600	AS001625	5	10	11	12										■
T27 PREMIUMFLEX	AC24S-BF	BEST LIFE	230	8,0	22,23	6.600	AS001600	5	10	11	12										■

ROTTLUFF

Base

Small grinding discs for metal – PREMIUMFLEX

Ordering example: AS000676

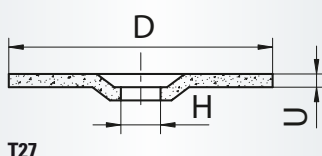

Packing unit:

see page 199

T27 = depressed centre

$v_{max.}$: 80 m/s



Description	Quality	Variant	Ø D mm	Thickness U mm	Bore H mm	n max. (1/min)	Product-Number	recommended for													
T27 PREMIUMFLEX	A24/30S-BF	BEST LIFE	76	6,0	10,00	20.100	AS000676	1	2	3											■



Taper sided, grinding wheel, Shape SE4 (nach ISO 603-12)

Ordering example: A2039080200320001

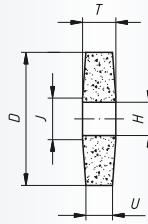

Packing unit:
10 pcs. per type
max. operating speed
50 m/s = 11.900 1/min

Description	Quality	D mm	T mm	U mm	H mm	J mm	Product-Number	recommended for	
SE4 08020.16	HK 24 M BA. soft	80	20	16	16	25	A2039080200320001	④ ⑤	■
SE4 08020.16	HK 16 P BA. hard	80	20	16	16	25	A2039080200320002	④ ⑤	■
SE4 08020.20	HK 24 M BA. soft	80	20	16	20	25	A2039080200320003	④ ⑤	■
SE4 08020.20	HK 16 P BA. hard	80	20	16	20	25	A2039080200320004	④ ⑤	■

These tools must be used with a flange which complies with the regulations of DIN 69864.



Cup wheels for angle grinders, shape SE 6 (to ISO 603-7)

Ordering example: A204108027027

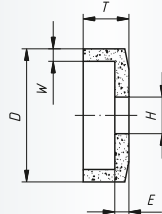

Packing unit:
5 pcs.
max. operating speed
50 m/s = 11.900 1/min

Description	Quality	D mm	T mm	H mm	W mm	E mm	Product-Number	recommended for	
SE6 08027.22	A 24 P BA	80	27	22,2	8	8	A204108027027	② ③ ⑤	■
SE6 08027.22	A 36 P BA	80	27	22,2	8	8	A2041080270270001	② ③ ⑤	■
SE6 08027.22	C 30 N BA	80	27	22,2	8	8	A204108027039	② ③ ④ ⑤ ⑥	■



Cup wheels for angle grinders, shape SE11 with screw thread

Ordering example: A2094110551111

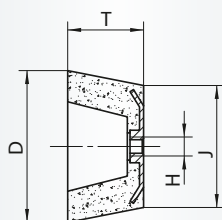

Packing unit:
10 pcs., up to Ø 130 mm 5 pcs.
 v_{max} : 50 m/s

Description	Quality	D mm	J mm	T mm	H mm	n max. (1/min)	Product-Number	recommended for	
SE11 110055.M14	A 16 Q BA	110	90	55	M14	8.600	A2094110551111	1 3 4 5	■
SE11 110055.M14	A 24 Q BA	110	90	55	M14	8.600	A2094110551211	1 3 4 5	■
SE11 110055.M14	A 36 Q BA	110	90	55	M14	8.600	A2094110551311	1 3 4 5	■
SE11 110055.M14	C 16 N BA	110	90	55	M14	8.600	A2094110551121	5 10 11 12 13	■
SE11 110055.M14	C 24 N BA	110	90	55	M14	8.600	A2094110551221	5 10 11 12 13	■
SE11 110055.M14	C 36 N BA	110	90	55	M14	8.600	A2094110551321	5 10 11 12 13	■
SE11 110055.M14	C 60 N BA	110	90	55	M14	8.600	A2094110551521	5 10 11 12 13	■
SE11 110055.M14	C 80 N BA	110	90	55	M14	8.600	A2094110551621	5 10 11 12 13	■
SE11 110055.M14	C 120 N BA	110	90	55	M14	8.600	A2094110551721	5 10 11 12 13	▲
SE11 130055.M14	A 16 Q BA	130	90	55	M14	7.300	A2094130551111	1 3 4 5	▲
SE11 130055.M14	A 24 Q BA	130	90	55	M14	7.300	A2094130551211	1 3 4 5	▲
SE11 130055.M14	C 16 N BA	130	90	55	M14	7.300	A2094130551121	5 10 11 12 13	■
SE11 130055.M14	C 24 N BA	130	90	55	M14	7.300	A2094130551221	5 10 11 12 13	■
SE11 130055.M14	C 36 N BA	130	90	55	M14	7.300	A2094130551321	5 10 11 12 13	■
SE11 130055.M14	C 60 N BA	130	90	55	M14	7.300	A2094130551521	5 10 11 12 13	▲

This product excels in

- High stock removal
- Long life
- Less vibration
- Low noise
- Aggressive cut

Applications for the A quality, brown aluminium oxide

- Welding seams
- Grinding in corners and edges
- Steel sheets
- Railway tracks
- Descaling
- Trimming of castings
- Thin profiles

Applications for the C quality, silicon carbide

- Ductile cast iron pipes
- Spherical castings
- Malleable cast iron
- Reinforced concrete
- Roof tiles
- Lime sand brick, artificial stone and dressed stone
- General stone
- Ceramic
- Grey iron castings
- Steel castings
- Marble
- Bottom plates
- Curbstones
- Fair faced brick
- Floating screed



Cup wheels for angle grinders, shape SE11 with steel cover and bore

Ordering example: A209411055511

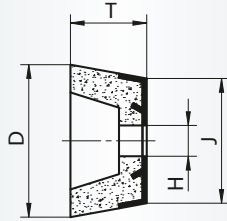

Packing unit:

10 pcs., up to Ø 130 mm 5 pcs.

v_{max}: 50 m/s

Description	Quality	D mm	J mm	T mm	H mm	n max. (1/min)	Product-Number	recommended for	
SE11 110055.22	A 16 Q BA	110	90	55	22,23	8.600	A2094110555111	1 3 4 5	■
SE11 110055.22	A 24 Q BA	110	90	55	22,23	8.600	A2094110555211	1 3 4 5	■
SE11 110055.22	A 36 Q BA	110	90	55	22,23	8.600	A2094110555311	1 3 4 5	▲
SE11 110055.22	A 60 Q BA	110	90	55	22,23	8.600	A2094110555511	1 3 4 5	▲
SE11 110055.22	C 16 N BA	110	90	55	22,23	8.600	A2094110555121	5 10 11 12 13	■
SE11 110055.22	C 24 N BA	110	90	55	22,23	8.600	A2094110555221	5 10 11 12 13	■
SE11 110055.22	C 60 N BA	110	90	55	22,23	8.600	A2094110555521	5 10 11 12 13	■
SE11 110055.22	C 80 N BA	110	90	55	22,23	8.600	A2094110555621	5 10 11 12 13	▲
SE11 110055.22	C 120 N BA	110	90	55	22,23	8.600	A2094110555721	5 10 11 12 13	■
SE11 130055.22	A 16 Q BA	130	90	55	22,23	7.300	A2094130555111	1 3 4 5	▲
SE11 130055.22	A 24 Q BA	130	90	55	22,23	7.300	A2094130555211	1 3 4 5	■
SE11 130055.22	C 16 N BA	130	90	55	22,23	7.300	A2094130555121	5 10 11 12 13	■
SE11 130055.22	C 24 N BA	130	90	55	22,23	7.300	A2094130555221	5 10 11 12 13	▲

This product excels in

- High stock removal
- Long life
- Less vibration
- Low noise
- Aggressive cut

Applications for the A quality, brown aluminium oxide

- Welding seams
- Grinding in corners and edges
- Steel sheets
- Railway tracks
- Descaling
- Trimming of castings
- Thin profiles

Applications for the C quality, silicon carbide

- Ductile cast iron pipes
- Spherical castings
- Malleable cast iron
- Reinforced concrete
- Roof tiles
- Lime sand brick, artificial stone and dressed stone
- General stone
- Ceramic
- Grey iron castings
- Steel castings
- Marble
- Bottom plates
- Curbstones
- Fair faced brick
- Floating screed

Diamondtools

212 Technical Information

213 Qualities and application

214 Vacuum-Brazed Diamond cutting discs

216 Diamond cutting discs

224 Diamond cup wheels



Product line marking

Product lines are labelled in the table header with the appropriate tabs. Further information on page **14** and **15**.

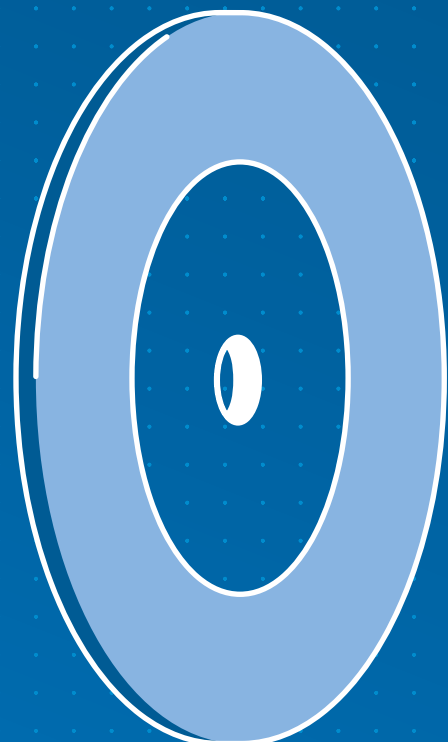

Technical Information

The Diamond

Diamonds are the hardest known material. They are selected depending on the field of application. For diamond blade manufacture synthetic diamonds are solely used. Compared to natural diamonds, their properties are reproducible and controllable. The following quality characteristics are significant for selecting diamonds:

- degree of purity
- defined breaking strength
- sharp edges
- consistent geometry

Diamonds are classified by quality levels and grain sizes.

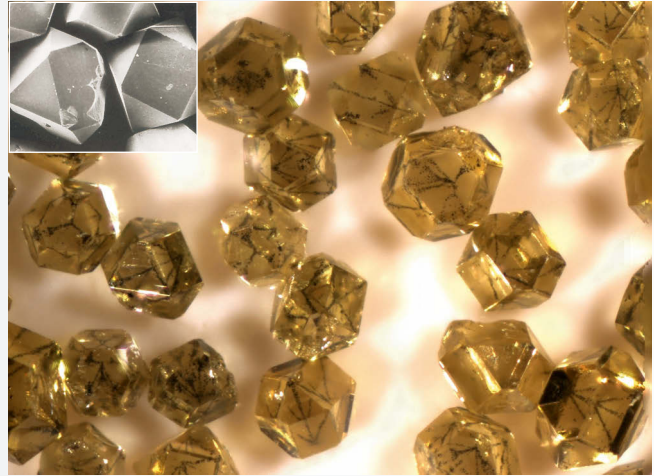

The Segment

The segments consist of diamond embedded metal powder. The metal bond must be suited to the material to be cut. The metal powder consists, for example, of bronze, cobalt, iron, metal carbides, tungsten carbide. The various properties of metal powder provide for sharpness and wear and tear of the segment. Segment coating is carried out by sintering. Therefore, abrasive materials require a hard bond against what hard materials call for soft bond.

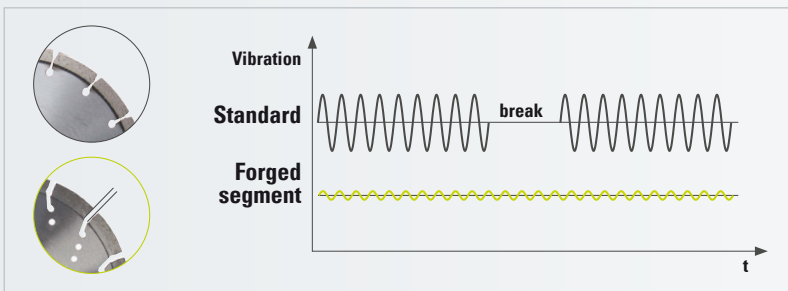
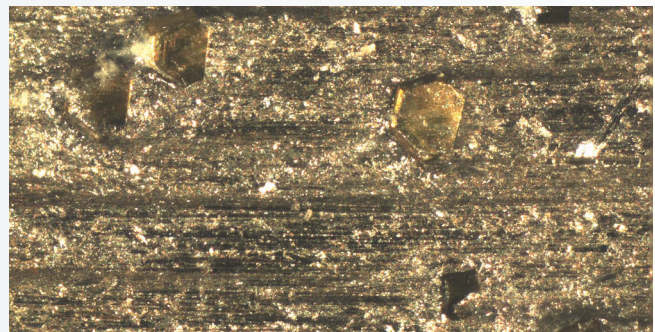

Comparison of cutting properties low vibration cutting discs with narrow gaps

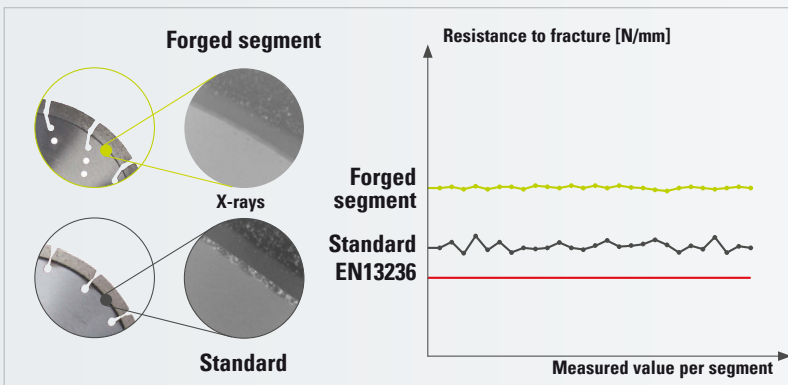

Welding properties of forged segment: with highest safety against fracture

Due to the patented forged segment geometry even high segments can be arranged with small gaps in between. This produces considerably lower vibration for the user. Another essential advantage is safety. The dense segments have been forged without any pores. This ensures welding properties which provide much more safety against fracture compared to the usual sintered segments.

- Universal and fast – owing to new types of alloys in the segments
- Less vibration – owing to a trapezoid segment geometry
- More safety – owing to segment feet which are free of pores and provide for the utmost safety
- Against a fracture of the segment
- Longer life – owing to higher segments and retarded diamond shedding

User instructions

Type	Catalogue page	Tiles			Granite, hard materials			Concrete			Building material				Asphalt, abrasive materials				Grey iron	
		Tiles	Fine stoneware	Granite tiles	Granite	Porphyry	Clinker bricks	Reinforced concrete	Exposed aggregate concrete	Concrete products	Bricks, masonry	Roof tiles	Gas concrete, pumice	Sand-lime brick	Refractory bricks	Screed	Fresh concrete	Asphalt	Grey iron	Segment height
Diamond cutting discs																				
VDCM	214																			
VDC	215																			
LD MULTI S13	216																			
LD 3 S13	217																			
TURBO HP S12	217																			
ABRASIV S13	223																			
LD7 S13	223																			
LD7 S10	224																			
LD3 S10	218																			
TURBO S10	218																			
BLUE CUT plus S10	219																			
BLUE CUT S10	221																			
BC7	219																			
BG-Laser	220																			
TC7	220																			
Tile cutting discs																				
FAST CUT S7	221																			
FLIESE S7	222																			
FC7	222																			
Diamond cup wheels																				
DST HP S5	224																			
DST S6	225																			
DST S5	225																			

High Performance
High Performance

- extremely quick cut, even through difficult materials
- Very good service life and designed for universal applications, for professional use

Industry
Industry

- quick cut and reliable
- long service life

Base
Base

- price-conscious and good

214 Vacuum-Brazed Diamond Cutting Disc



High Performance

VDCM Multi, the exceptional cutting disc for nearly any workpiece

Ordering example: A34911152022

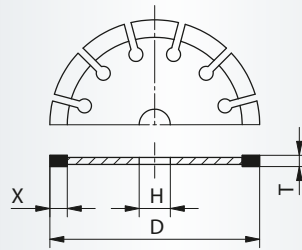

Packing unit:
1 pc.
 v_{max} : 80 m/s

VDC MULTI
Series

Description	D mm	Height of segments X mm	Width of segments T mm	H mm	n max. (1/min)	Product-Number	recommended for	
VDCM 115020	115	7,0	2,0	22,23	13.300	A34911152022	① 5 8 10 11 12	■
VDCM 125020	125	7,0	2,0	22,23	12.200	A34911252022	① 5 8 10 11 12	■
VDCM 180026	180	7,0	2,6	22,23	8.500	A34911802622	① 5 8 10 11 12	■
VDCM 230030	230	7,0	3,0	22,23	6.600	A34912303022	① 5 8 10 11 12	■

The segment coating made of carbide granulates prevents the disc from getting stuck in soft workpieces. The result is a clean cut.

Special properties:

- Low temperatures
- No dust and build-up of odours
- No expiry date
- No reduction in diameter
- vacuum-brazed
- very aggressive

Ideal for cutting of

- Grey cast iron (GG, GGG)
- Glass-fibre reinforced plastic (GRP)
- Steel
- Bricks
- Reinforced concrete
- Stone, tiles, wood



High Performance

VDC, a revolution in the cutting of grey cast iron

Ordering example: A34901152222

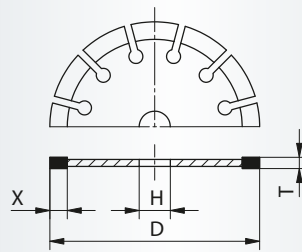

Packing unit:
1 pc.
 v_{max} : 80 m/s

VDC MULTI
Series

Description	D mm	Height of segments X mm	Width of segments T mm	H mm	n max. (1/min)	Product-Number	recommended for	
VDC 115022	115	7,0	2,2	22,23	13.300	A34901152222	5	■
VDC 125022	125	7,0	2,2	22,23	12.200	A34901252222	5	■
VDC 180026	180	7,0	2,6	22,23	8.500	A34901802622	5	■
VDC 230030	230	7,0	3,0	22,23	6.600	A34902303022	5	■
VDC 350036	350	7,0	3,6	32,00	4.400	A34903503632	5	■

Special properties:

- Low temperatures
- No dust and build-up of odours
- No expiry date
- No reduction in diameter
- vacuum-brazed
- very aggressive
- extreme tool life

Ideal for cutting of

- Grey cast iron (GG, GGG)
- Glass-fibre reinforced plastic (GFK)
- burning-in

Not suitable for high-alloyed nickel-containing materials.

LD Multi S13, the professional disc for concrete and construction material

Ordering example: A344031151213083

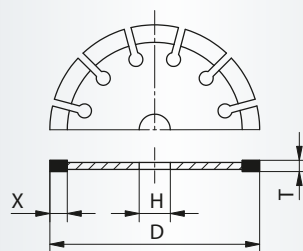
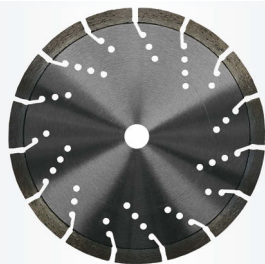

Packing unit:

1 pc.
 v_{max} : 80 m/s
 Ø 300, 350, 400 mm: 100m/s

Description	D mm	Height of segments X mm	Width of segments T mm	H mm	n max. (1/min)	Product-Number	recommended for	
LD Multi S13	115	13	2,4	22,23	13.300	A344031151213083	10 11 14	■
LD Multi S13	125	13	2,4	22,23	12.200	A344031251213093	10 11 14	■
LD Multi S13	150	13	2,4	22,23	10.200	A344031501213113	10 11 14	■
LD Multi S13	180	13	2,4	22,23	8.500	A344031801213133	10 11 14	■
LD Multi S13	230	13	2,6	22,23	6.600	A344032301213153	10 11 14	■
LD Multi S13	300	13	2,8	25,4	6.400	A344033002213183	10 11 14	▲
LD Multi S13	350	13	3,0	25,4	5.500	A344033502213213	10 11 14	▲
LD Multi S13	400	13	3,2	25,4	4.800	A344034002213243	10 11 14	▲

This diamond cutting disc excels in:

- Most universal properties along with optimum cutting speed
- Long life
- Extreme running smoothness
- Low vibration due to trapezoid segment geometry
- The production process for the segments in forging technology has been covered by patents

Bonding method: laser welded

Note: Cutting discs with 300 to 400 mm diameter are available on request with 20 mm and 30 mm bore. Please refer to the chart on page 213 for detailed information on applications.

LD3 S13, for top performance in granite, concrete and construction material

Ordering example: A344031151713083

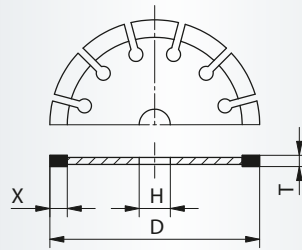

Packing unit:

1 pc.

v_{max} : 80 m/s

Ø 300, 350, 400 mm: 100m/s

Description	D mm	Height of segments X mm	Width of segments T mm	H mm	n max. (1/min)	Product-Number	recommended for	
LD3 S13	115	13	2,4	22,23	13.300	A344031151713083	10 11 14	■
LD3 S13	125	13	2,4	22,23	12.200	A344031251713093	10 11 14	■
LD3 S13	150	13	2,4	22,23	10.200	A344031501713113	10 11 14	▲
LD3 S13	180	13	2,4	22,23	8.500	A344031801713133	10 11 14	▲
LD3 S13	230	13	2,6	22,23	6.600	A344032301713153	10 11 14	■
LD3 S13	300	13	2,8	25,4	6.400	A344033002713183	10 11 14	▲
LD3 S13	350	13	3,0	25,4	5.500	A344033502713213	10 11 14	▲
LD3 S13	400	13	3,2	25,4	4.800	A344034002713243	10 11 14	▲

This diamond cutting disc excels in:

- Most universal properties along with optimum cutting speed
- Long life
- Extreme running smoothness
- Low vibration due to trapezoid segment geometry
- The production process for the segments in forging technology has been covered by patents

Bonding method: laser welded

Note: Cutting discs with 300 to 400 mm diameter are available on request with 20 mm and 30 mm bore. Please refer to the chart on page 213 for detailed information on applications.

Turbo HP S12, with turbo segments, also suitable for reinforced concrete

Ordering example: A344031151212093

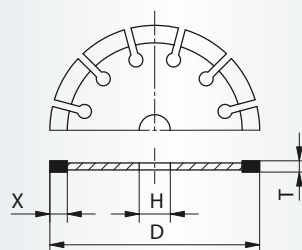
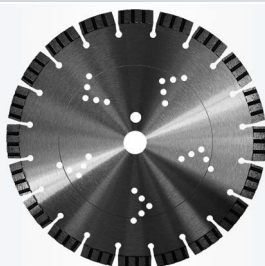

Packing unit:

1 pc.

v_{max} : 80 m/s

Description	D mm	Height of segments X mm	Width of segments T mm	H mm	n max. (1/min)	Product-Number	recommended for	
TURBO HP S12	115	12	2,4	22,23	13.300	A344031151212093	10 11 14	■
TURBO HP S12	125	12	2,4	22,23	12.200	A344031251212103	10 11 14	■
TURBO HP S12	150	12	2,4	22,23	10.200	A344031501212123	10 11 14	▲
TURBO HP S12	180	12	2,6	22,23	8.500	A344031801212143	10 11 14	■
TURBO HP S12	230	12	3,0	22,23	6.600	A344032301212153	10 11 14	■

This diamond cutting disc excels in:

- A wide field of applications
- Long life
- Good cutting speed

Bonding method: laser welded

Please refer to the chart on page 213 for detailed information on applications.

LD3 S10, for a high cutting rate in concrete and construction material

Ordering example: A344131151210083

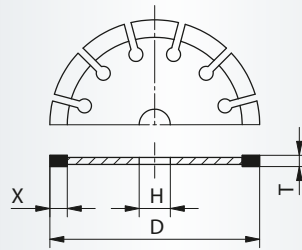

Packing unit:
1 pc.
 v_{max} : 80 m/s

Description	D mm	Height of segments X mm	Width of segments T mm	H mm	n max. (1/min)	Product-Number	recommended for	
LD3 S10	115	10	2,3	22,23	13.300	A344131151210083	10 11	■
LD3 S10	125	10	2,3	22,23	12.200	A344131251210093	10 11	■
LD3 S10	150	10	2,3	22,23	10.200	A344131501210113	10 11	▲
LD3 S10	180	10	2,3	22,23	8.500	A344131801210143	10 11	■
LD3 S10	230	10	2,3	22,23	6.600	A344132301210163	10 11	■

This diamond cutting disc excels in:

- Universal use in concrete/building material
- Excellent price-performance ratio

Bonding method: laser welded

Please refer to the chart on page 213 for detailed information on applications.

Turbo S 10, the disc for the clear cut in building material or concrete

Ordering example: A344141151110013

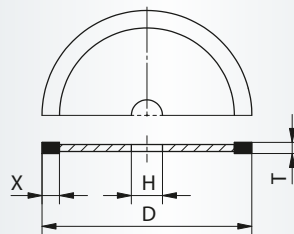

Packing unit:
1 pc.
 v_{max} : 80 m/s

Description	D mm	Height of segments X mm	Width of segments T mm	H mm	n max. (1/min)	Product-Number	recommended for	
TURBO S10	115	10	2,2	22,23	13.300	A344141151110013	10 11	■
TURBO S10	125	10	2,2	22,23	12.200	A344141251110013	10 11	■
TURBO S10	150	10	2,2	22,23	10.200	A344141501110013	10 11	▲
TURBO S10	180	10	2,6	22,23	8.500	A344141801110013	10 11	■
TURBO S10	230	10	2,6	22,23	6.600	A344142301110013	10 11	■

This diamond cutting disc excels in:

- Various applications
- Clear cuts

Please refer to the chart on page 213 for detailed information on applications.

BLUE CUT plus S10, the universal disc for construction sites

Ordering example: A344141151110093

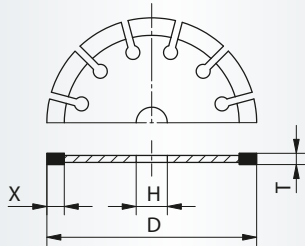

Packing unit:
1 pc.
 v_{max} : 80 m/s

Description	D mm	Height of segments X mm	Width of segments T mm	H mm	n max. (1/min)	Product-Number	recommended for	
BLUE CUT plus S10	115	10	1,8	22,23	13.300	A344141151110093	10 11	■
BLUE CUT plus S10	125	10	1,8	22,23	12.200	A344141251110093	10 11	■
BLUE CUT plus S10	180	10	2,2	22,23	8.500	A344141801110093	10 11	■
BLUE CUT plus S10	230	10	2,4	22,23	6.600	A344142301110093	10 11	■

This diamond cutting disc excels in:

- An optimum price-performance ratio

Please refer to the chart on page 213 for detailed information on applications.



BC7, the cost-effective disc for building and handicraft

Ordering example: A345241151107085

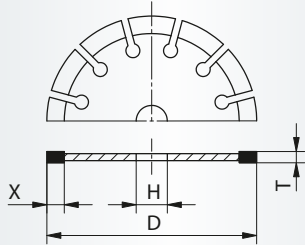

Packing unit:
1 pc.
 v_{max} : 80 m/s

Description	D mm	Height of segments X mm	Width of segments T mm	H mm	n max. (1/min)	Product-Number	recommended for	
BC7	115	7	2,0	22,23	13.300	A345241151107085	10 11	■
BC7	125	7	2,0	22,23	12.200	A345241251107095	10 11	■
BC7	230	7	2,5	22,23	6.600	A345242301107165	10 11	■

Please refer to the chart on page 213 for detailed information on applications.

220 Diamond cutting discs

ROTLUFF

Base

TC7, the cost-effective turbo disc for a clean cut

Ordering example: A345241151107775

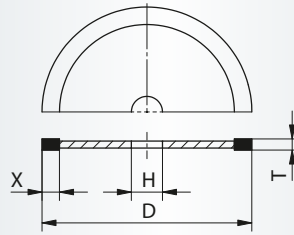

Packing unit:
1 pc.
 v_{max} : 80 m/s

Description	D mm	Height of segments X mm	Width of segments T mm	H mm	n max. (1/min)	Product-Number	recommended for	
TC7	115	7	2,4	22,23	13.300	A345241151107775	⑩ ⑪	■
TC7	125	7	2,6	22,23	12.200	A345241251107775	⑩ ⑪	■
TC7	230	7	3,2	22,23	6.600	A345242301107775	⑩ ⑪	■

Please refer to the chart on page 213 for detailed information on applications.

ROTLUFF

Base

BG-Laser, the price-conscious disc for granite and concrete

Ordering example: A345231251207105

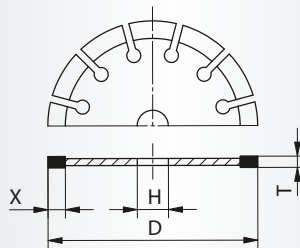

Packing unit:
1 pc.
 v_{max} : 80 m/s

Description	D mm	Height of segments X mm	Width of segments T mm	H mm	n max. (1/min)	Product-Number	recommended for	
BG-Laser	125	7	2,2	22,23	12.200	A345231251207105	⑩ ⑪ ⑭	■
BG-Laser	230	7	2,5	22,23	6.600	A345232301207165	⑩ ⑪ ⑭	■

Bonding method: laser welded

Please refer to the chart on page 213 for detailed information on applications.

Blue Cut S10, the popular disc for construction sites

Ordering example: A345241001110075

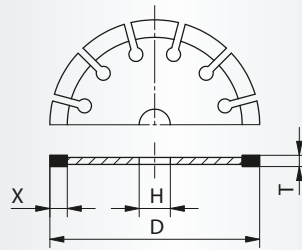

Packing unit:
1 pc.
 v_{max} : 80 m/s

Description	D mm	Height of segments X mm	Width of segments T mm	H mm	n max. (1/min)	Product-Number	recommended for	
Blue Cut S10	100	10	1,8	16,00	15.300	A345241001110075	10 11	■
Blue Cut S10	115	10	2,0	22,23	13.300	A345241151110085	10 11	■
Blue Cut S10	125	10	2,0	22,23	12.200	A345241251110095	10 11	■
Blue Cut S10	150	10	2,2	22,23	10.200	A345241501110125	10 11	■
Blue Cut S10	180	10	2,4	22,23	8.500	A345241801110145	10 11	■
Blue Cut S10	230	10	2,5	22,23	6.600	A345242301110165	10 11	■

Please refer to the chart on page 213 for detailed information on applications.

FAST CUT S7, the extra thin turbo cutting disc for ceramics and stoneware

Ordering example: A344091151107013

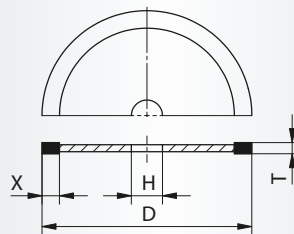

Packing unit:
1 pc.
 v_{max} : 80 m/s

Description	D mm	Height of segments X mm	Width of segments T mm	H mm	n max. (1/min)	Product-Number	recommended for	
FAST CUT S7	115	7	1,2	22,23	13.300	A344091151107013	12 14	■
FAST CUT S7	125	7	1,2	22,23	12.200	A344091251107013	12 14	■
FAST CUT S7	150	7	1,2	22,23	10.200	A344091501107013	12 14	▲
FAST CUT S7	180	7	1,6	22,23	8.500	A344091801107013	12 14	▲
FAST CUT S7	230	7	1,6	22,23	6.600	A344092301107013	12 14	■

This diamond cutting disc excels in:

- An extra-thin segment coating and a reinforced flange area
- Fast and clear cuts through the hardest tiles

Please refer to the chart on page 213 for detailed information on applications.

222 Diamond cutting discs

ROTLUFF

Industry

FLIESE S7, the popular cutting disc for tiles and ceramics

Ordering example: A34411151107013

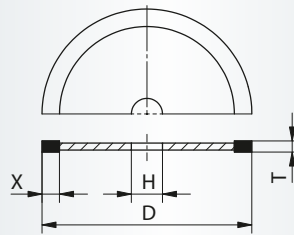

Packing unit:

1 pc.

v_{max} : 80 m/s

Description	D mm	Height of segments X mm	Width of segments T mm	H mm	n max. (1/min)	Product-Number	recommended for	
FLIESE S7	115	7	1,5	22,23	13.300	A34411151107013	12	■
FLIESE S7	125	7	1,5	22,23	12.200	A344111251107013	12	■
FLIESE S7	150	7	1,5	22,23	10.200	A344111501107013	12	▲
FLIESE S7	180	7	1,6	22,23	8.500	A344111801107013	12	■
FLIESE S7	230	7	1,65	22,23	6.600	A344112301107013	12	■

This diamond cutting disc excels in:

- Clean cuts into glazed ceramics

Please refer to the chart on page 213 for detailed information on applications.



ROTLUFF

Base

FC7, the cost-effective tile cutting disc

Ordering example: A34521151107015

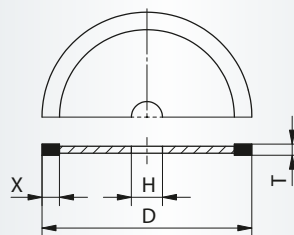

Packing unit:

1 pc.

v_{max} : 80 m/s

Description	D mm	Height of segments X mm	Width of segments T mm	H mm	n max. (1/min)	Product-Number	recommended for	
FC7	115	7	1,8	22,23	13.300	A34521151107015	12	■
FC7	125	7	2,0	22,23	12.200	A345211251107015	12	■
FC7	230	7	2,5	22,23	6.600	A345212301107015	12	■

This diamond cutting disc excels in:

- An optimum price-performance ratio

Please refer to the chart on page 213 for detailed information on applications.

ABRASIV S13, the professional disc for fresh concrete and much more

Ordering example: A344053002213203

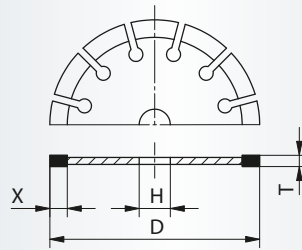

Packing unit:

1 pc.

v_{max} : 80 m/s

Ø 300, 350, 400 mm: 100m/s

Description	D mm	Height of segments X mm	Width of segments T mm	H mm	n max. (1/min)	Product-Number	recommended for	
ABRASIV S13	115	13	2,4	22,23	13.300	A344051151213083	10 11 15 16	■
ABRASIV S13	125	13	2,4	22,23	12.200	A344051251213093	10 11 15 16	■
ABRASIV S13	180	13	2,4	22,23	8.500	A344051801213133	10 11 15 16	▲
ABRASIV S13	230	13	2,6	22,23	6.600	A344052301213163	10 11 15 16	■
ABRASIV S13	300	13	2,8	25,4	6.400	A344053002213203	10 11 15 16	▲
ABRASIV S13	350	13	3,0	25,4	5.500	A344053502213243	10 11 15 16	▲
ABRASIV S13	400	13	3,2	25,4	4.800	A344054002213283	10 11 15 16	▲
ABRASIV S13	450	13	3,6	25,4	3.400	A344054502213253	10 11 15 16	▲
ABRASIV S13	500	13	3,6	25,4	3.100	A344055002213303	10 11 15 16	▲

This diamond cutting disc excels in:

- Very universal properties along with optimum life
- Extreme running smoothness
- Low vibration due to trapezoid segment geometry
- The production process for the segments in forging technology has been covered by patents

Bonding method: laser welded

Note: Cutting discs with 300 to 400 mm diameter are available on request with 20 mm bore.

Please refer to the chart on page 213 for detailed information on applications.

LD7 S13, for top performance in asphalt

Ordering example: A344073002213183

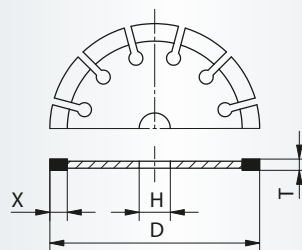

Packing unit:

1 pc.

v_{max} : 80 m/s

Ø 300, 350, 400 mm: 100m/s

Description	D mm	Height of segments X mm	Width of segments T mm	H mm	n max. (1/min)	Product-Number	recommended for	
LD7 S13	300	10	2,8	25,4	6.400	A344073002213183	15 16	■
LD7 S13	350	10	3,0	25,4	5.400	A344073502213213	15 16	■
LD7 S13	400	10	3,2	25,4	4.700	A344074002213243	15 16	■
LD7 S13	450	10	3,6	25,4	3.400	A344074502213253	15 16	▲
LD7 S13	500	10	3,6	25,4	3.100	A344075002213303	15 16	▲

This diamond cutting disc excels in:

- forging technology
- laser welded

Please refer to the chart on page 213 for detailed information on applications.

LD7 S10 for a perfect cutting of asphalt

Ordering example: A344173002210183

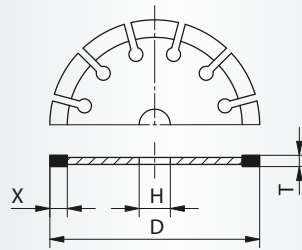

Packing unit:
1 pc.
 v_{max} : 80 m/s

Description	D mm	Height of segments X mm	Width of segments T mm	H mm	n max. (1/min)	Product-Number	recommended for	
LD7 S10	300	10	3,2	25,4	5.100	A344173002210183	15 16	▲
LD7 S10	350	10	3,2	25,4	4.400	A344173502210213	15 16	■
LD7 S10	400	10	3,5	25,4	3.800	A344174002210243	15 16	■
LD7 S10	450	10	4,0	25,4	3.400	A344174502210283	15 16	▲
LD7 S10	500	10	4,0	25,4	3.100	A344175002210303	15 16	▲

This diamond cutting disc excels in:

- Especially shaped segments providing extreme running smoothness and core protection

Bonding method: laser welded

Note: Cutting discs with 300 to 400 mm diameter are available on request with 20 mm bore.

Please refer to the chart on page 213 for detailed information on applications.

DST HP S5 to meet the highest expectations for stock removal and smooth running

Ordering example: A344331001505083

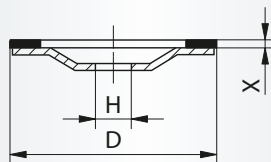

Packing unit:
1 pc.
 v_{max} : 80 m/s

Description	D mm	Height of segments X mm	H mm	n max. (1/min)	Product-Number	recommended for	
DST HP S5	100	5	22,23	15.300	A344331001505083	10 11 14	▲
DST HP S5	125	5	22,23	12.200	A344331251505083	10 11 14	■
DST HP S5	180	5	22,23	8.500	A344331801505123	10 11 14	▲

This diamond cup wheel excels in:

- High performance segments for maximum stock removal
- Universal segment alloy for concrete/granite
- Low vibration during working due to inductive welded segments (no imbalance in tool)
- Optimum suction at segment

Please refer to the chart on page 213 for detailed information on applications.

DST S6, the cup wheel for universal application

Ordering example: A344431251606183

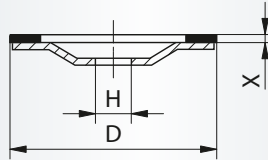

Packing unit:
1 pc.
 $v_{max.}$: 80 m/s

Description	D mm	Height of segments X mm	H mm	n max. (1/min)	Product-Number	recommended for	
DST S6	125	6	22,23	12.200	A344431251606183	10 11	■
DST S6	180	6	22,23	8.500	A344431801606183	10 11	▲

This diamond cup wheel excels in:

- Excellent price-performance ratio
- Optimum arrangement of segments for high grinding performance and clean surface

Please refer to the chart on page 213 for detailed information on applications.



DST S5, the cost-effective cup wheel for numerous application

Ordering example: A345531151607185

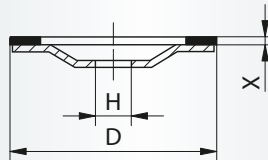

Packing unit:
1 pc.
 $v_{max.}$: 80 m/s

Description	D mm	Height of segments X mm	H mm	n max. (1/min)	Product-Number	recommended for	
DST S5	115	5	22,23	13.300	A345531151607185	10 11	■
DST S5	125	5	22,23	12.200	A345531251607185	10 11	■

Please refer to the chart on page 213 for detailed information on applications.

Notes

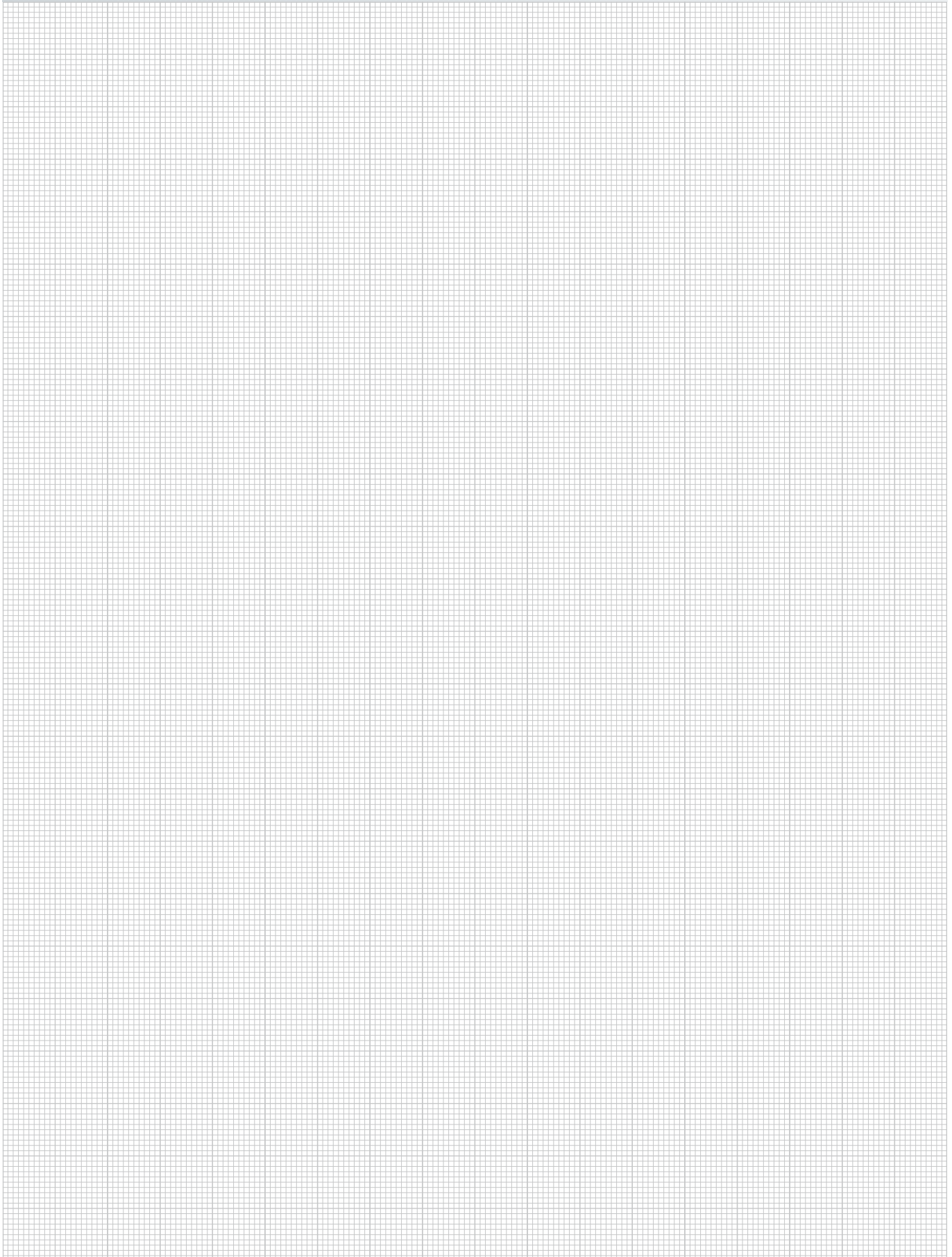

Flexible Grinding and Polishing Tools

228 General Information/Qualities

231 Lamellar Flap Discs

259 Mounted flap wheels of abrasive cloth

275 Flap wheel consisting of an abrasive fleece and abrasive cloth combination

285 Flap wheels

295 Flap rolls

301 Abrasive Bands and Mandrels

315 Abrasive Rolls and Mandrels

319 Abrasive Caps and Abrasive Sleeves

331 Abrasive Discs and Mandrels

349 Fibre discs, backing plates, economy rolls, abrasive sheets and fleece rolls





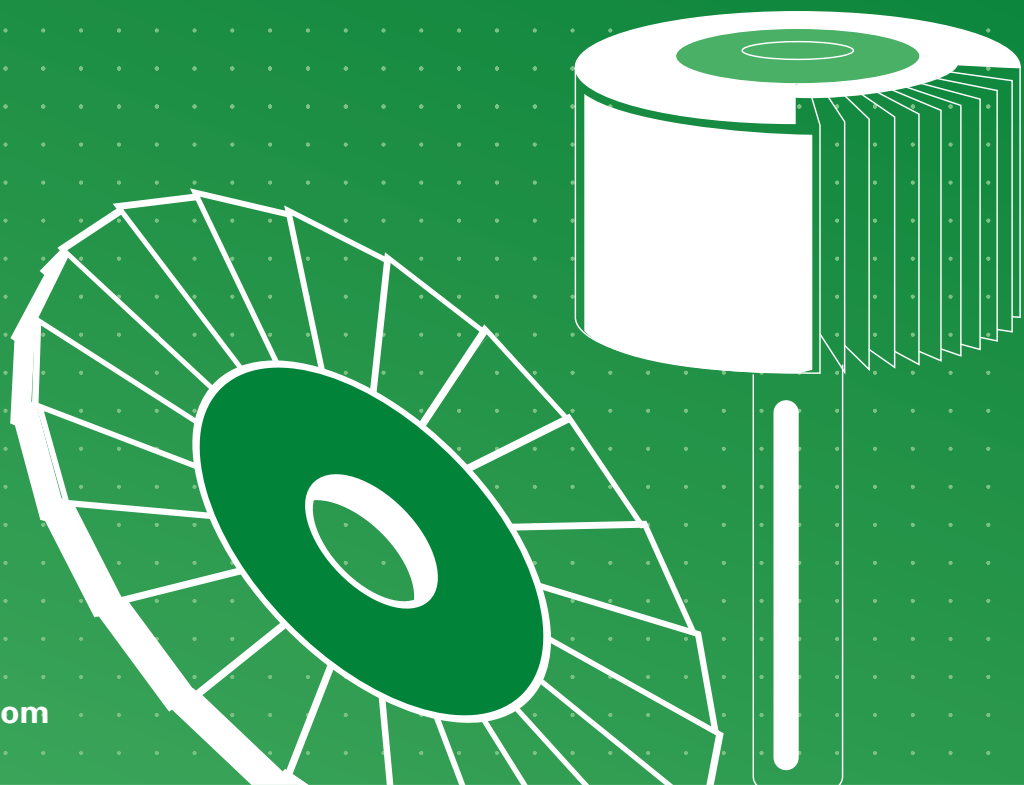

359 AS-Cleaning fleece

Product line marking

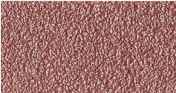
Product lines are labelled in the table header with the appropriate tabs. Further information on page **14** and **15**.

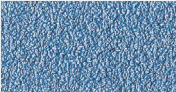

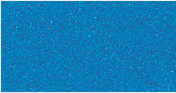
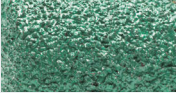
Qualities and Applications

Quality		Characteristics	Applications/Grinding	Available as	Page
 NK	Abrasive cloth with reg. Aluminium Oxide	tough grain	Forged steel, malleable iron, grey cast iron, carbon steel, deep-drawn steels, steel band, zinc die castings, nonferrous metals, wood	flap discs mounted flap wheels flap wheels flap rolls bands abrasive rolls caps abrasive sleeves discs Economy rolls fibre discs sheets of abrasive cloth	249–251 254 261–268 271–272 287–288 297 304–307 310–313 317–318 321 323–327 329 334 344–345 347 352–353 356 357
 NKE	Abrasive cloth using reg. Aluminium Oxide with special coating containing active grinding additives	tough grain	Chrome-nickel and other alloyed steels, deep drawn steels, titanium and titanium alloyed steels, heat resistant steels	mounted flap wheels discs	269 335
 ZK	Abrasive cloth with Zirconia Alum. Oxide	very tough and resilient grain	Forged steels, metals difficult to machine and with extreme hard surfaces i.e. welds, titanium and titanium alloys, heat resistant steels	flap discs abrasive belts discs fibre discs	237, 241, 243, 245, 248–255 307–308, 313 336, 341–342 351
 Z POWER	Abrasive cloth using Zirconia Alum. Oxide with special coating containing active grinding additives	optimum stock removal rate, excellent tool life	all alloyed steels	lamellar flap discs abrasive bands abrasive discs	236, 240 303 336
 ZKS	Abrasive cloth using Zirconia Alum. Oxide with special coating containing active grinding additives	M-Bonding with polyester fibre excellent stock removal rate with very good tool life	Forged steels, metals difficult to machine and with extreme hard surfaces i.e. welds, titanium and titanium alloys, heat resistant steels	flap discs	241 248 253 256
 NKS	Abrasive cloth using reg. Aluminium Oxide with special coating containing active grinding additives	optimum stock removal rate, excellent tool life	corrosion and heat resistant steel	abrasive caps	321 323 325 327
 SIC	Abrasive cloth with Silicon carbide	cool cutting; special quality for the aircraft industry	Aluminium and aluminium alloys, brittle material, glass ceramics, titanium and titanium alloys, heat resistant steels, plastics	flap discs mounted flap wheels discs	241 270 337, 344

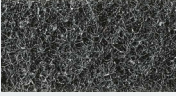
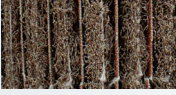
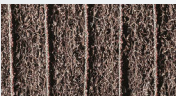
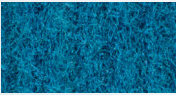
Quality		Characteristics	Applications/Grinding	Available as	Page
 D	Diamond coated abrasive cloth	For those instances where conventional abrasive cloth provides too little stock removal	Extreme tool life benefit versus conventional abrasive cloth. Ideally suited for particularly difficult-to-machine and hard work-piece materials. Glass, GRP and CRP, carbide, titanium, stone, ceramic	abrasive belts abrasive discs	303 346
 CERAMIC	Abrasive cloth ceramic grain	optimum stock removal rate without shredding of grain. Very stable due to reinforced backing. Cool cutting	stainless steel, nickel alloys	flap discs abrasive belts discs fibre discs	236, 240, 247, 249 304 337 351
 A	Abrasive fleece with reg. Aluminium Oxide	polishing effect through fibre structure, consistent results due to continuous exposure of new grit particles	Chrome-nickel alloys and other stainless steels, zinc die castings, non-ferrous metals, wood	flap discs mounted flap wheels flap wheels fleece mops flap rolls fleece pads/ fleece rolls	257 277–278 288–292 293 298 358
 C	Abrasive fleece with Silicon carbide	polishing effect through fibre structure, consistent results due to continuous exposure of new grit particles	Titanium and titanium alloys, silver and silverplated, aluminium and aluminium alloys, plastics	flap discs mounted flap wheels flap wheels flap rolls fleece pads	257 279 288–292 300 358
 TF	Abrasive fleece/cloth reg. Aluminium Oxide reinforced fleece	Abrasive cloth lamellars and abrasive fleece lamellars of our combined mounted flap wheels wear off more equal. Higher stock removal efficiency.	Ideal for surface finishing of metalsheet components such as stainless steel sinks and containers	mounted flap wheels flap rolls	281 299
 A	Abrasive fleece/abrasive cloth combined Al.-Oxide	intensified grinding action through combination of fleece and abrasive cloth	Chrome-nickel alloys and other stainless steels, zinc die castings, non-ferrous metals, wood	flap discs mounted flap wheels flap rolls	256 280–282 299–300
 C	Abrasive fleece/abrasive cloth combined Sil.-Carbide	intensified grinding action through combination of fleece and abrasive cloth	Titanium and titanium alloys, silver and silverplated, aluminium and aluminium alloys, plastics	flap discs mounted flap wheels	256 283
 AS	Polyamid-Fleece	impregnated with aggressive abrasive grit	removal of paint and adhesives, cement and concrete residues, derusting, restoring and polishing of a wide variety of surfaces.	AS-Tools	361–362
 Z	Abrasive fleece, zirconia aluminium oxide	Polishing effect through fibre structure, more aggressive	Cr-Ni and other stainless steels, zinc injection mouldings, non-ferrous metals	Mounted flap wheels	277

Information

General

Our flexible grinding and polishing tools are manufactured from high quality abrasive cloth and abrasive fleece. They consist of a flexible backing coated with abrasive grain (please refer to page 228 and 229)

Backings used: cloth, polyester fibre, fleece, fibre

Grain types used:

aluminium oxide (NK), silicon carbide (SIC), zirconia aluminium oxide (ZK), ceramic (ceramic)

Our flexible grinding and polishing tools are available in several different shapes and dimensions; they cover a wide spectrum of application i.e. from high stock removal to achieving an extremely fine surface finish.

Operating recommendations

An increase in speed makes the abrasive grit act finer; a reduction in speed makes the abrasive grit act coarser.

Do not apply high pressure; performance will not increase and tool life will be reduced.

If stock removal is insufficient select a coarser grit size, do not increase pressure. The use of grinding additives can improve the efficiency.

Safety instructions

Please note our recommended operating speeds.

When using and storing flexible grinding and polishing tools, please take note of the safety regulations and regulations for prevention of accidents, including the FEPA-safety recommendations.

The tools are marked with pictograms according to FEPA recommendations for the use of coated abrasives.

Points to consider when choosing the optimum grinding and polishing tool:

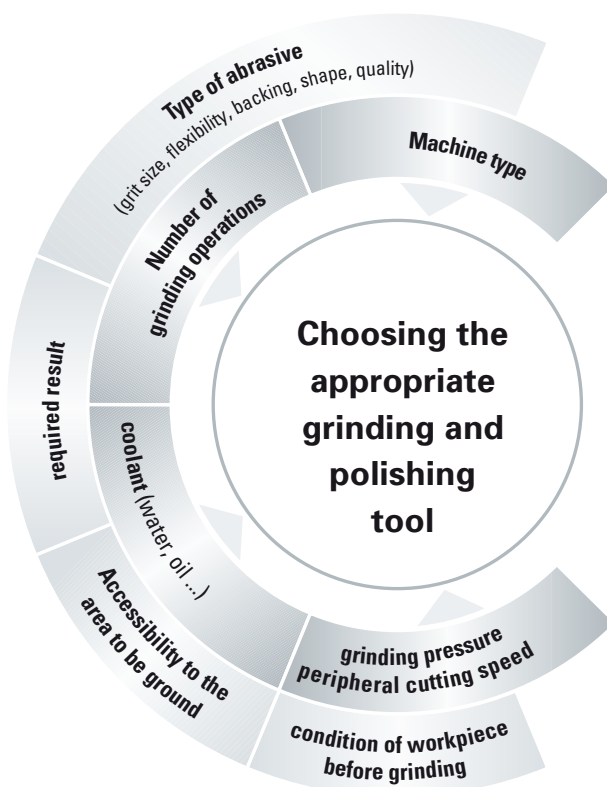

Lamellar Flap Discs

228 Quality and Applications

232 Generell Information

234 SLTT our turbo-flap disc – iQ-Series

238 V2 Power – iQ-Series

242 V3 Control – iQ-Series

244 V4 Master – Innovation for rounding off

246 SLTflex – The flexible innovation – iQ-Series

249 SLTO/SLTR – with Ceramic-grit

249 SLTO/SLTR – reinforced fibre backing

253 SLTZ – with special active grinding additives

253 SLTS – with vertical flaps

254 SLTB/SLTF, The robust – with steel backing

255 SLTK – with plastic backing

256 SLTC, The NAWAROFLEX with the backing plate made of renewable raw materials

256 SLTM, NAWAROFLEX® – to improve surface finish

257 SLTV, NAWAROFLEX® – for finishing and polishing

257 SLTP – Polishing disc

Product line marking

Product lines are labelled in the table header with the appropriate tabs. Further information on page **14** and **15**.



Information

General

LUKAS offers a flap disc for almost every application. These abrasive tools are produced with a wide selection of backing materials (e.g. glass fibre, resin, metal and even with a bio-degradable raw material) to suit every application.

The large choice of grit sizes cover high stock removal applications (from grit size 36) to the finish machining application (grit size 240)

Ergonomics

Where lamellar flap discs are used, you can achieve clear ergonomic advantages compared to conventional grinding discs.

For example, the noise level perceived is cut in half during grinding, and vibration can also be reduced considerably. In addition, the tools are generally lighter and can be used with less pressure.

These advantages mean that they create a positive working climate and lead to fatigue-free working without impairing your health.

The flap discs are available in 100 mm diameter (with 16 mm bore) and in diameters 115 mm, 125 mm, 150 mm and 178 mm (22.23 mm bore); They fit all commonly used angle grinders.

You can choose between the flat or angled versions depending on application.

Examples of application:

- deburring
- fettling
- derusting
- finishing
- Machining of Welds

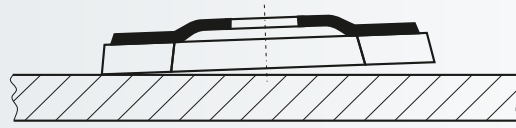

The flat shape is designed to grind edges and flat surfaces with a working angle of 0° to 15° degrees.

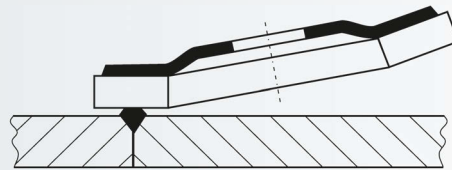

The angled shape is designed for spot grinding e.g. a weld seam with an ideal working angle of 15° to 25° degrees.

Always the right tool



iq Series

Innovative quality



Tools of our High Performance Line have been integrated into our iQ-Series product group.

Flap Discs in this product group guarantee the highest level of grinding performance due to a patented lamella shape and orientation.

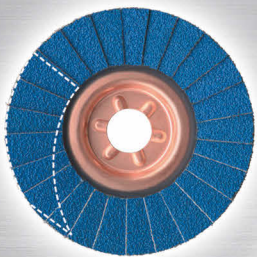

SLTT
Series

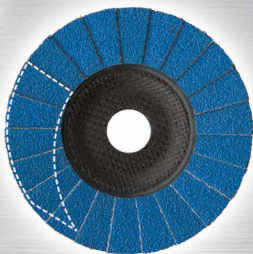

V2 Power
Series



V3 Control
Series

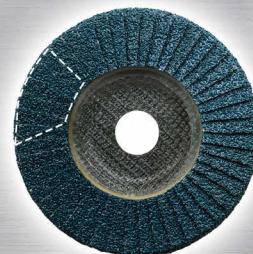

V4 Master
Series

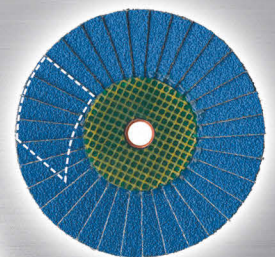

SLTflex
Series

Always the right tool

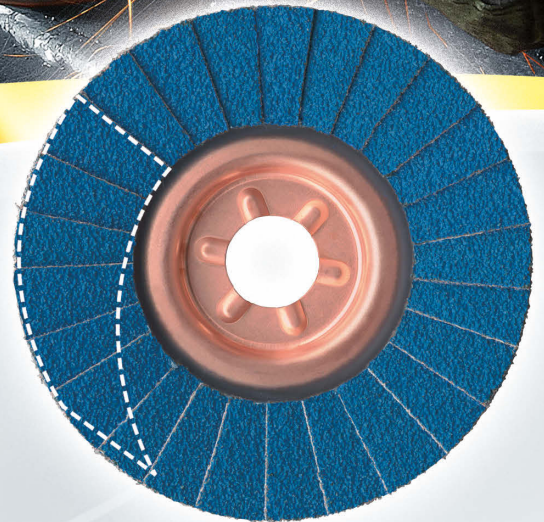

SLTT – for highest chip removal!

Feel the efficiency compared to grinding wheels or conventional lamellar flap discs.

Ideal for

- removing weld seams
- deburring
- fettling
- fine finishing
- rust removal

SLTT
iQ Series

A patented new design and configuration of flaps (more grains in action)

Characteristics

- exceptional stock-removal capability
- enormous tool life
- strong steel backing plate
- quite
- less vibration

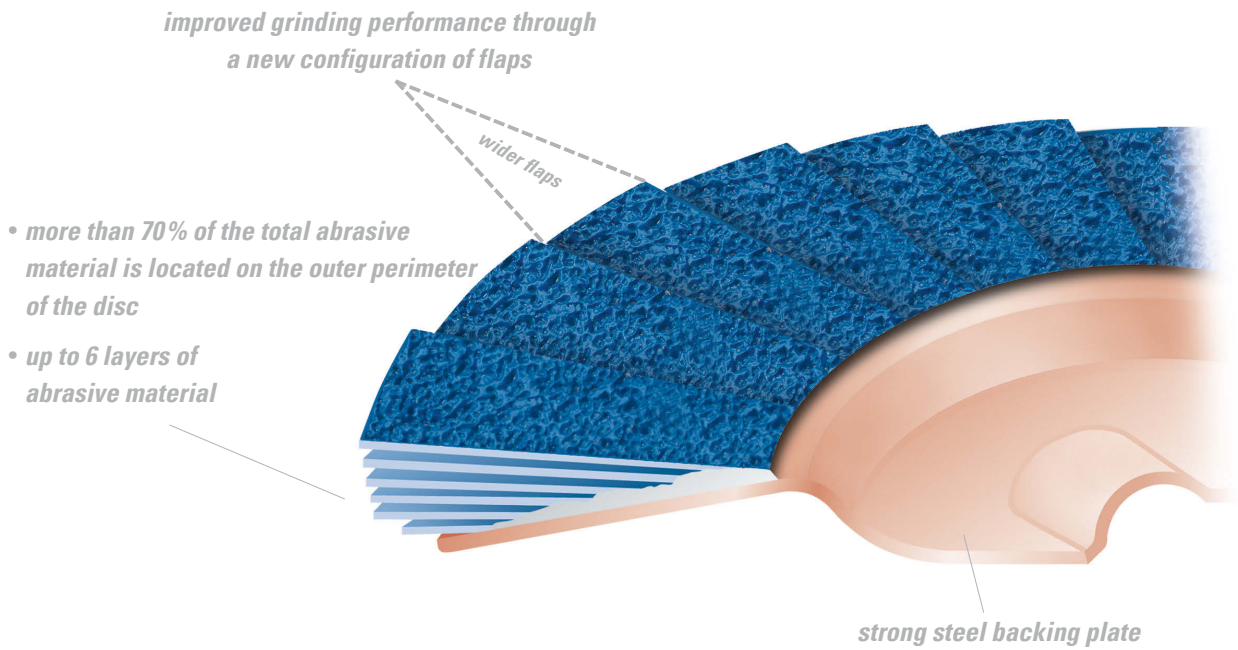

The three qualities of the iQ series:

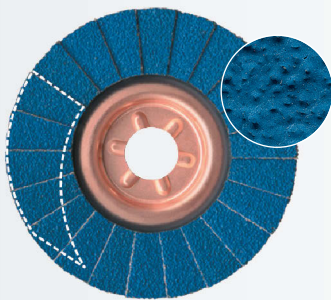

INOX

Z-Power coated abrasive

- recently developed for the machining of stainless steel
- no glazing or heating of flaps, owing to top size coating
- equally efficient for both edge and surface applications
- iron-sulphur-chlorine free

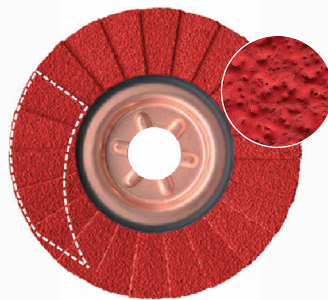

Heavy Duty

Ceramic coated abrasive

- recently developed for the most demanding and severe applications
- particularly robust for edge grinding, on heat treated steels, surface scale or coated surfaces
- iron-sulphur-chlorine free

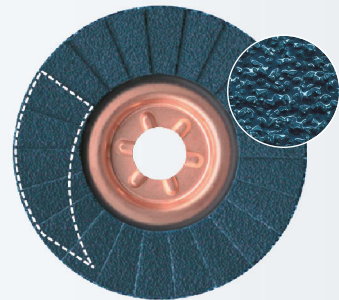

Steel

ZK coated abrasive

- optimized for universal application on a wide variety of steels and aluminium
- tough grain with a high degree of resistance to pressure
- quicker, more aggressive and longer tool life when compared with our current ZKS quality



SLTT INOX, our Turbo Flap Disc to work on stainless steel

Ordering example: A27201150400045

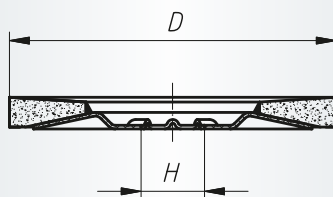
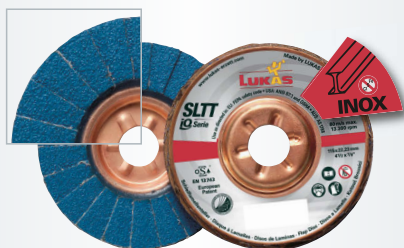

Packing unit:
10 pcs. per type

v_{max} : 80 m/s

Z POWER = Abrasive cloth using Zirconia Alum. Oxide with special coating containing active grinding additives



Description	Grits	D mm	H mm	n max (1/min)	Product-Number	recommended for	
SLTT 115	Z Power 40	115	22,23	13.300	A27201150400045	① ② ③ ④	■
SLTT 115	Z Power 60	115	22,23	13.300	A27201150600045	① ② ③ ④	■
SLTT 125	Z Power 40	125	22,23	12.200	A27201250400045	① ② ③ ④	■
SLTT 125	Z Power 60	125	22,23	12.200	A27201250600045	① ② ③ ④	■
SLTT 150	Z Power 40	150	22,23	10.200	A27201500400045	① ② ③ ④	■
SLTT 178	Z Power 40	178	22,23	8.500	A27201780400045	① ② ③ ④	■
SLTT 178	Z Power 60	178	22,23	8.500	A27201780600045	① ② ③ ④	■

Properties:

- No glazing or heating of flaps, owing to top size coating
- equally efficient for both edge and surface applications
- iron-sulphur-chlorine free



SLTT Heavy Duty, our Turbo Flap Disc for roughest application

Ordering example: A27201150400050

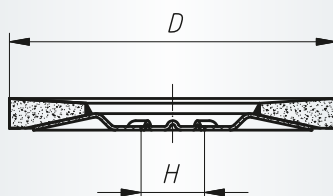

Packing unit:
10 pcs. per type

v_{max} : 80 m/s

Ceramic = Abrasive cloth ceramic grain



Description	Grits	D mm	H mm	n max (1/min)	Product-Number	recommended for	
SLTT 115	Ceramic 40	115	22,23	13.300	A27201150400050	① ② ③ ④ ⑤ ⑥ ⑦ ⑧	■
SLTT 115	Ceramic 60	115	22,23	13.300	A27201150600050	① ② ③ ④ ⑤ ⑥ ⑦ ⑧	■
SLTT 125	Ceramic 40	125	22,23	12.200	A27201250400050	① ② ③ ④ ⑤ ⑥ ⑦ ⑧	■
SLTT 125	Ceramic 60	125	22,23	12.200	A27201250600050	① ② ③ ④ ⑤ ⑥ ⑦ ⑧	■
SLTT 150	Ceramic 40	150	22,23	10.200	A27201500400050	① ② ③ ④ ⑤ ⑥ ⑦ ⑧	■
SLTT 178	Ceramic 40	178	22,23	8.500	A27201780400050	① ② ③ ④ ⑤ ⑥ ⑦ ⑧	■
SLTT 178	Ceramic 60	178	22,23	8.500	A27201780600050	① ② ③ ④ ⑤ ⑥ ⑦ ⑧	■

Properties:

- particularly robust for edge grinding, on heat treated steels, surface scale or coated surfaces
- iron-sulphur-chlorine free





High Performance

SLTT Steel, our Turbo Flap Disc for universal application on steel and aluminium

Ordering example: A27201150400065

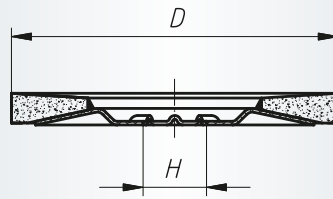
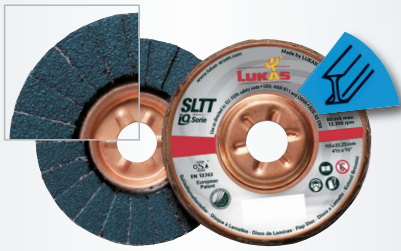

Packing unit:
10 pcs. per type

v_{max} : 80 m/s

ZK = Abrasive cloth with Zirconia Alum. Oxide



Description	Grits	D mm	H mm	n max (1/min)	Product-Number	recommended for	
SLTT 115	ZK 40	115	22,23	13.300	A27201150400065	1 2 3 4 5 6 7 8	■
SLTT 115	ZK 60	115	22,23	13.300	A27201150600065	1 2 3 4 5 6 7 8	■
SLTT 125	ZK 40	125	22,23	12.200	A27201250400065	1 2 3 4 5 6 7 8	■
SLTT 125	ZK 60	125	22,23	12.200	A27201250600065	1 2 3 4 5 6 7 8	■
SLTT 150	ZK 40	150	22,23	10.200	A27201500400065	1 2 3 4 5 6 7 8	■
SLTT 150	ZK 60	150	22,23	10.200	A27201500600065	1 2 3 4 5 6 7 8	■
SLTT 178	ZK 40	178	22,23	8.500	A27201780400065	1 2 3 4 5 6 7 8	■
SLTT 178	ZK 60	178	22,23	8.500	A27201780600065	1 2 3 4 5 6 7 8	■

Properties:

- tough grain with a high degree of resistance to pressure
- quicker, more aggressive and longer tool life when compared with our current ZKS quality

Always the right tool

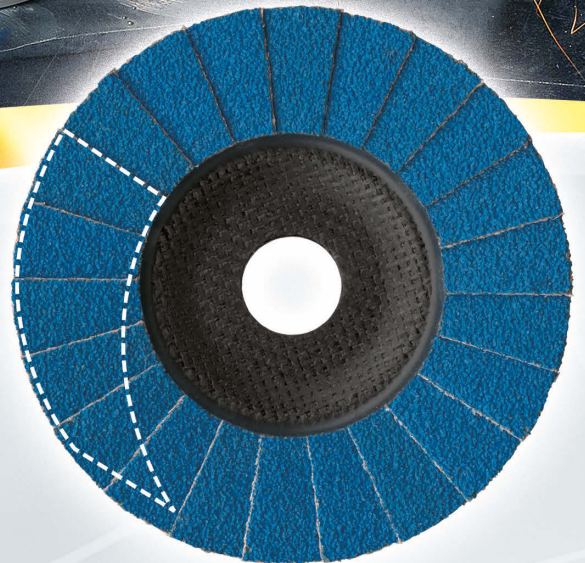

V2 Power – for general purpose!

Feel the efficiency compared to conventional lamellar flap discs.

Ideal for

- removing weld seams
- deburring
- fettling
- fine finishing
- rust removal



A patented new design and configuration of flaps (more grains in action)

Characteristics

- exceptional stock-removal capability
- outstanding tool life
- robust fibre backing plate

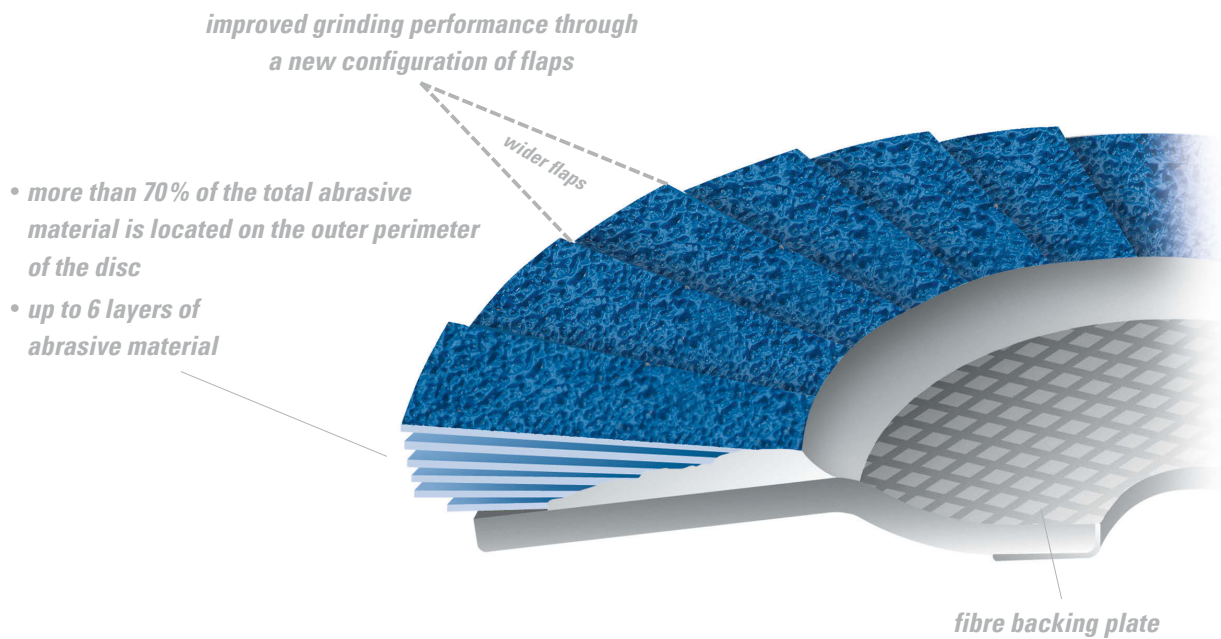

The four qualities in the iQ Series – for all materials and for every application!

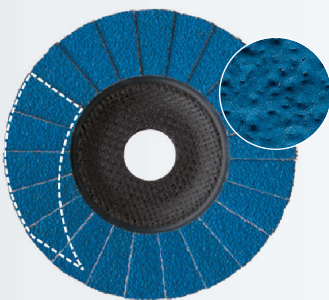

INOX

Z-Power coated abrasive

- recently developed for the machining of stainless steel
- no glazing or heating of flaps, owing to top size coating
- equally efficient for both edge and surface applications
- iron-sulphur-chlorine free



Heavy Duty

Ceramic coated abrasive

- recently developed for the most demanding and severe applications
- particularly robust for edge grinding, on heat treated steels, surface scale or coated surfaces
- iron-sulphur-chlorine free

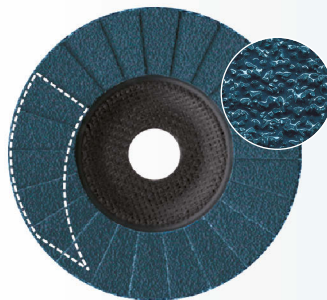

Steel

ZK coated abrasive

- optimized for universal application on a wide variety of steels and aluminium
- tough grain with a high degree of resistance to pressure
- quicker, more aggressive and longer tool life when compared with our current ZKS quality



ALU

SIC – coated abrasive

- specially suited for weld preparation and finishing of aluminium
- also ideal for fibre reinforced materials such as CRP and GRP



V2 Power INOX to work on stainless steel

Ordering example: A27441150401445

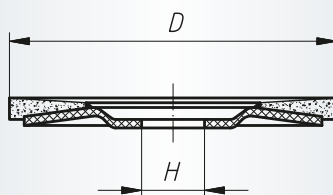

Packing unit:
10 pcs. per type

v_{max} : 80 m/s

Z POWER = Abrasive cloth using Zirconia Alum. Oxide with special coating containing active grinding additives



Description	Grits	D mm	H mm	n max. (1/min)	Product-Number	recommended for	
V2 POWER 115	Z Power 40	115	22,23	13.300	A27441150401445	① ② ③ ④	■
V2 POWER 115	Z Power 60	115	22,23	13.300	A27441150601445	① ② ③ ④	■
V2 POWER 125	Z Power 40	125	22,23	12.200	A27441250401445	① ② ③ ④	■
V2 POWER 125	Z Power 60	125	22,23	12.200	A27441250601445	① ② ③ ④	■
V2 POWER 178	Z Power 40	178	22,23	8.500	A27441780401445	① ② ③ ④	■
V2 POWER 178	Z Power 60	178	22,23	8.500	A27441780601445	① ② ③ ④	■

Properties:

- no glazing or heat generation
- iron-sulphur-chlorine free
- equally efficient for both edge and surface applications



V2 Power Heavy Duty for roughest application

Ordering example: A27441150401450

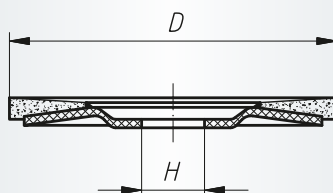

Packing unit:
10 pcs. per type

v_{max} : 80 m/s

Ceramic = ceramic grain



Description	Grits	D mm	H mm	n max. (1/min)	Product-Number	recommended for	
V2 POWER 115	Ceramic 40	115	22,23	13.300	A27441150401450	① ② ③ ④ ⑤ ⑥ ⑦ ⑧	■
V2 POWER 115	Ceramic 60	115	22,23	13.300	A27441150601450	① ② ③ ④ ⑤ ⑥ ⑦ ⑧	■
V2 POWER 125	Ceramic 40	125	22,23	12.200	A27441250401450	① ② ③ ④ ⑤ ⑥ ⑦ ⑧	■
V2 POWER 125	Ceramic 60	125	22,23	12.200	A27441250601450	① ② ③ ④ ⑤ ⑥ ⑦ ⑧	■
V2 POWER 178	Ceramic 40	178	22,23	8.500	A27441780401450	① ② ③ ④ ⑤ ⑥ ⑦ ⑧	■
V2 POWER 178	Ceramic 60	178	22,23	8.500	A27441780601450	① ② ③ ④ ⑤ ⑥ ⑦ ⑧	■
V2 POWER 230	Ceramic 40	230	22,23	6.600	A27442300401428	① ② ③ ④ ⑤ ⑥ ⑦ ⑧	■

Properties:

- particularly robust for edge grinding, on heat treated steels, surface scale or coated surfaces
- iron-sulphur-chlorine free





High Performance

V2 Power Steel for universal application on steel and aluminium

Ordering example: A27441000401465

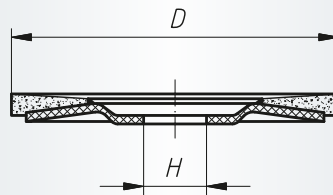

Packing unit:
10 pcs. per type



v_{max} : 80 m/s

ZK = Abrasive cloth with Zirconia Alum. Oxide
ZKS = Zirconia Alum. Oxide with special coating containing active grinding additives

Description	Grits	D mm	H mm	n max. (1/min)	Product-Number	recommended for	
V2 POWER 100	ZK 40	100	16	15.300	A27441000401465	1 2 3 4 5 6 7 8	■
V2 POWER 100	ZK 60	100	16	15.300	A27441000601465	1 2 3 4 5 6 7 8	■
V2 POWER 115	ZK 40	115	22,23	13.300	A27441150401465	1 2 3 4 5 6 7 8	■
V2 POWER 115	ZK 60	115	22,23	13.300	A27441150601465	1 2 3 4 5 6 7 8	■
V2 POWER 125	ZK 40	125	22,23	12.200	A27441250401465	1 2 3 4 5 6 7 8	■
V2 POWER 125	ZK 60	125	22,23	12.200	A27441250601465	1 2 3 4 5 6 7 8	■
V2 POWER 178	ZK 40	178	22,23	8.500	A27441780401465	1 2 3 4 5 6 7 8	■
V2 POWER 178	ZK 60	178	22,23	8.500	A27441780601465	1 2 3 4 5 6 7 8	■
V2 POWER 230	ZKS 40	230	22,23	6.600	A27442300401418	1 2 3 4 5 6 7 8	■

Properties:

- tough grain with a high degree of resistance to pressure



High Performance

V2 POWER ALU

Ordering example: A27441150401434

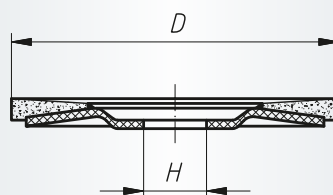

Packing unit:
10 pcs. per type



v_{max} : 80 m/s

SIC = Silicon carbide

Description	Grits	D mm	H mm	n max. (1/min)	Product-Number	recommended for	
V2 POWER 115	SIC 36	115	22,23	13.300	A27441150361434	6 7 8	■
V2 POWER 115	SIC 40	115	22,23	13.300	A27441150401434	6 7 8	■
V2 POWER 125	SIC 36	125	22,23	12.200	A27441250361434	6 7 8	■
V2 POWER 125	SIC 40	125	22,23	12.200	A27441250401434	6 7 8	■
V2 POWER 178	SIC 24	178	22,23	8.500	A27441780241434	6 7 8	■
V2 POWER 178	SIC 36	178	22,23	8.500	A27441780361434	6 7 8	■

Properties:

- silicon carbide (SIC) ideally suited for preparation and finishing of weld seams with various aluminium alloys
- Silicon carbide (SIC) ideally suited for the machining of contemporary workpiece materials such as CRP or GRP

Always the right tool

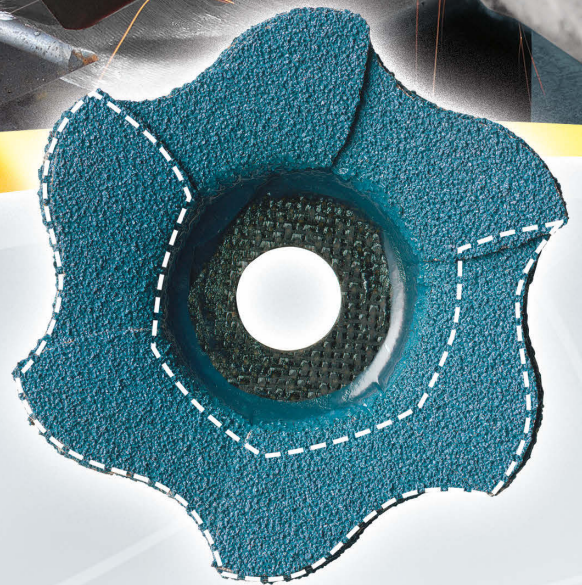

V3 Control – see what we can do!

The V3 Control allows complete control during application.

Ideal for:

- finishing
- fettling
- weld seam finishing
- rust removal

V3Control
iQ Series

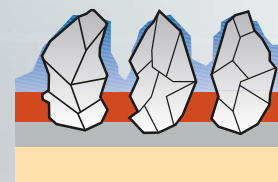

*Using a high quality coated abrasive
(zirconia with a coating of active grinding additives)*



High Performance

V3 Control – see what needs to be done

Ordering example: A27451150401411

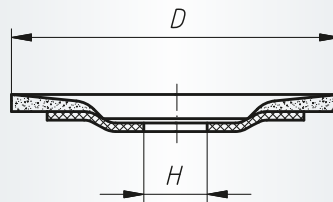

Packing unit:
10 pcs. per type
 v_{max} : 80 m/s
ZK = Zirconia Alum. Oxide

io Series

Description	Grits	D mm	H mm	n max. (1/min)	Product-Number	recommended for	
V3 CONTROL 115	ZK 40	115	22,23	13.300	A27451150401411	1 2 3 4 5 6 7	■
V3 CONTROL 115	ZK 60	115	22,23	13.300	A27451150601411	1 2 3 4 5 6 7	■
V3 CONTROL 115	ZK 80	115	22,23	13.300	A27451150801411	1 2 3 4 5 6 7	■
V3 CONTROL 125	ZK 40	125	22,23	12.200	A27451250401411	1 2 3 4 5 6 7	■
V3 CONTROL 125	ZK 60	125	22,23	12.200	A27451250601411	1 2 3 4 5 6 7	■
V3 CONTROL 125	ZK 80	125	22,23	12.200	A27451250801411	1 2 3 4 5 6 7	■

Best stock removal rates and long tool life

As a result of further development of this outstanding product type, an even better use of the abrasive material has been achieved.

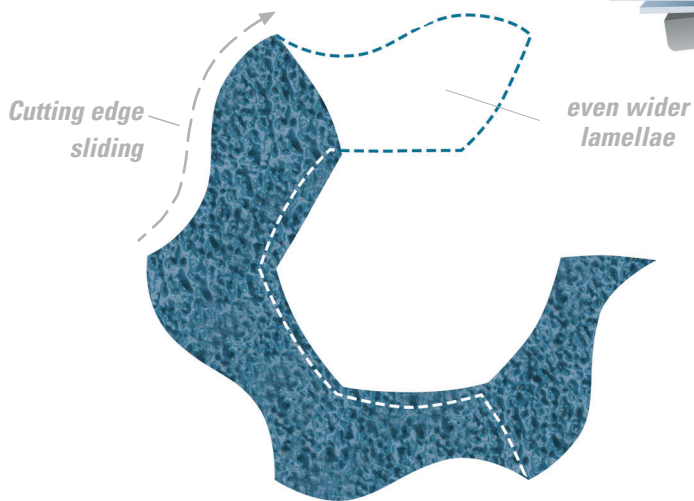
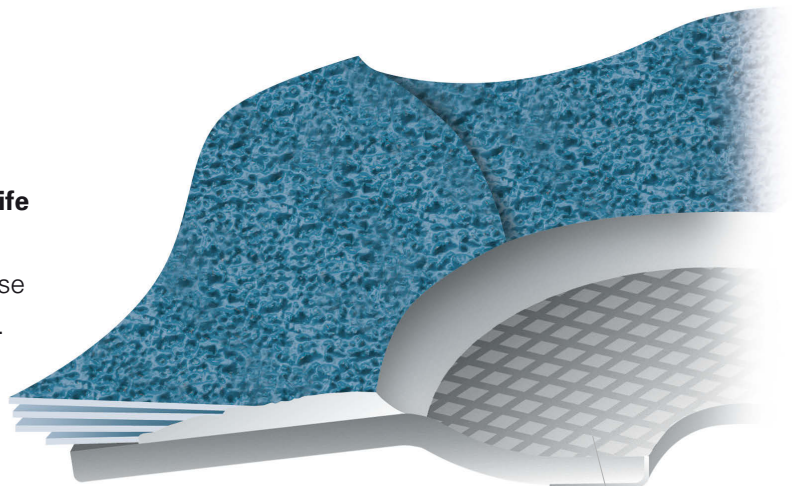

fibre backing plate

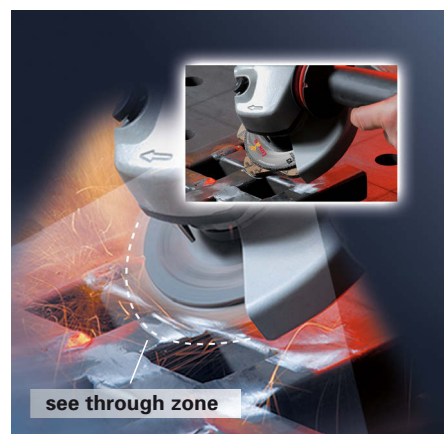

see through zone

Safe application without snagging

The curved geometry of the lamellae prevents snagging of the tool on the workpiece.

See what we can do! 6 laser cut abrasive flaps for exceptional stock removal.

Always the right tool



**New: Innovation –
for rounding off!**

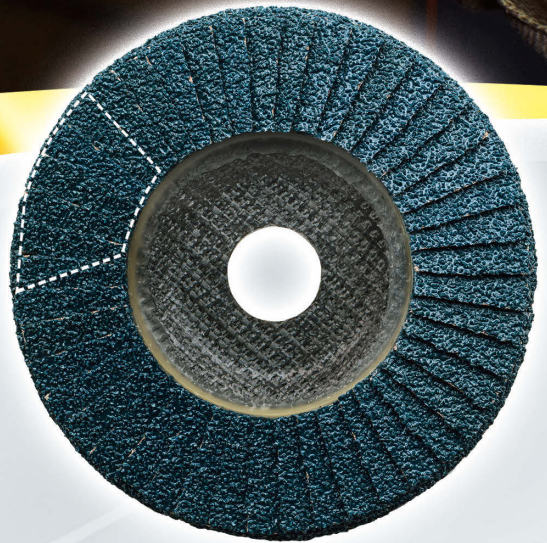

**V4 Master – extremely aggressive and durable due
to patented design and configuration of flaps**

Areas of application

- rounding sharp edges
- removing weld seams
- treatment of thermal cuts

V4 Master
i@ Series

Customized for your industry:

- Steel and tank construction
- Shipyards and offshore
- Machine and plant engineering



V4 Master – Master of its class

Ordering example: A27471150401465

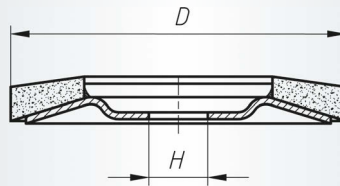

Packing unit:
10 pcs. per type

v_{max} : 80 m/s

ZK = Abrasive cloth with Zirconia Alum. Oxide



Description	Grit	D mm	H mm	n max (1/min)	Product-Number	recommended for	
V4 MASTER 115	ZK 40	115	22,23	13.300	A27471150401465	1 2 3 4 6 7	■
V4 MASTER 115	ZK 60	115	22,23	13.300	A27471150601465	1 2 3 4 6 7	■
V4 MASTER 125	ZK 40	125	22,23	12.200	A27471250401465	1 2 3 4 6 7	■
V4 MASTER 125	ZK 60	125	22,23	12.200	A27471250601465	1 2 3 4 6 7	■
V4 MASTER 178	ZK 40	178	22,23	8.500	A27471780401465	1 2 3 4 6 7	■

Characteristics:

- extreme stock removal
- good edge retention
- deep recess around the bore
- long tool life
- low noise and low vibration
- ergonomically due to less effort
- iron-sulphur-chlorine free

Always the right tool

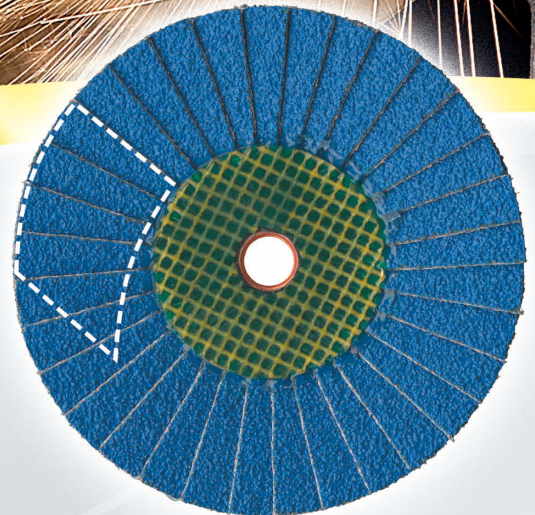

SLTflex – for the awkward areas!

Feel the efficiency compared to conventional lamellar flap discs or fibre discs.

Ideal for:

- machining of fillet welds
- deburring
- fettling
- fine finishing
- rust removal

SLTflex
iQ Series

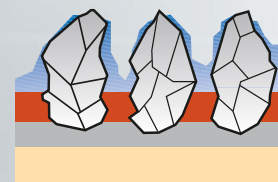

*Using a high quality coated abrasive
(zirconia with a coating of active grinding additives)*



High Performance

SLTflex Ceramic, the powerful disc for radii and fillet welds

Ordering example: A272711504070

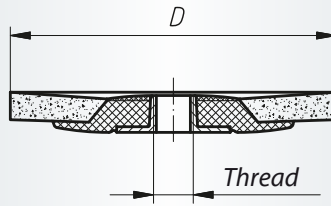

Packing unit:
10 pcs. per type
 v_{max} : 80 m/s
Ceramic = ceramic grain



Description	Grits	D mm	Thread	n max (1/min)	Product-Number	recommended for		
SLTFLEX 115	Ceramic 40	115	M14	13.300	A272711504070	1 2 3 4 5 6 7	■	NEW
SLTFLEX 115	Ceramic 60	115	M14	13.300	A272711506070	1 2 3 4 5 6 7	■	NEW
SLTFLEX 125	Ceramic 40	125	M14	12.200	A272712504070	1 2 3 4 5 6 7	■	NEW
SLTFLEX 125	Ceramic 60	125	M14	12.200	A272712506070	1 2 3 4 5 6 7	■	NEW

Properties:

- high flexibility due to elongated flaps (no disturbing backing plate)
- simple tool change (backing plate / pad and mounting nut no longer required)
- extreme tool life

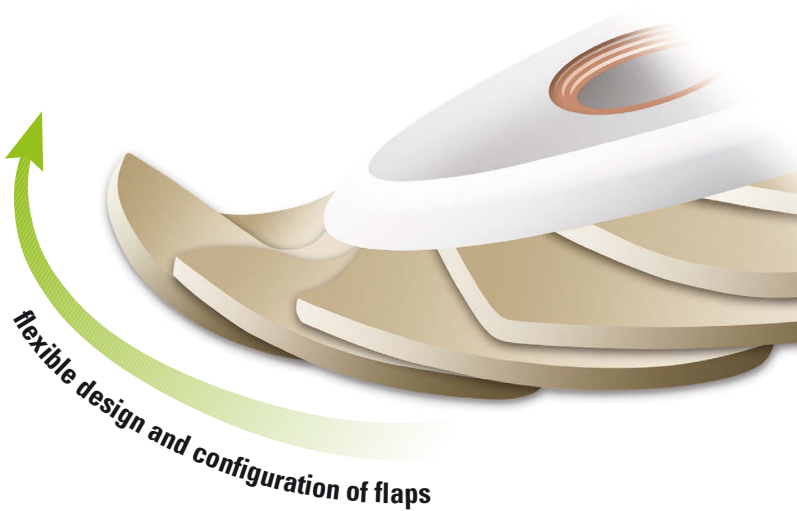



SLTflex – for radii and fillet weldings

Ordering example: A272910004018

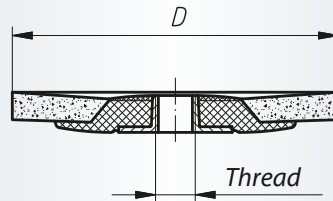

Packing unit:
10 pcs. per type

v_{max} : 80 m/s

ZKS = Zirconia Alum. Oxide with special coating containing active grinding additives

ZK = Zirconia Alum. Oxide



Description	Grits	D mm	Thread	n max (1/min)	Product-Number	recommended for	
SLTFLEX 100	ZKS 40	100	M10	15.300	A272910004018	1 2 3 4 5 6 7	■
SLTFLEX 100	ZKS 60	100	M10	15.300	A272910006018	1 2 3 4 5 6 7	■
SLTFLEX 100	ZKS 80	100	M10	15.300	A272910008018	1 2 3 4 5 6 7	■
SLTFLEX 115	ZKS 40	115	M14	13.300	A272711504018	1 2 3 4 5 6 7	■
SLTFLEX 115	ZKS 40	115	5/8"	13.300	A272811504018	1 2 3 4 5 6 7	■
SLTFLEX 115	ZKS 60	115	M14	13.300	A272711506018	1 2 3 4 5 6 7	■
SLTFLEX 115	ZKS 60	115	5/8"	13.300	A272811506018	1 2 3 4 5 6 7	■
SLTFLEX 115	ZK 80	115	M14	13.300	A272711508016	1 2 3 4 5 6 7	■
SLTFLEX 115	ZK 80	115	5/8"	13.300	A272811508018	1 2 3 4 5 6 7	■
SLTFLEX 115	ZK 120	115	M14	13.300	A272711512016	1 2 3 4 5 6 7	■
SLTFLEX 115	ZK 120	115	5/8"	13.300	A272811512018	1 2 3 4 5 6 7	■
SLTFLEX 125	ZKS 40	125	M14	12.200	A272712504018	1 2 3 4 5 6 7	■
SLTFLEX 125	ZKS 40	125	5/8"	12.200	A272812504018	1 2 3 4 5 6 7	■
SLTFLEX 125	ZKS 60	125	M14	12.200	A272712506018	1 2 3 4 5 6 7	■
SLTFLEX 125	ZKS 60	125	5/8"	12.200	A272812506018	1 2 3 4 5 6 7	■
SLTFLEX 125	ZK 80	125	M14	12.200	A272712508016	1 2 3 4 5 6 7	■
SLTFLEX 125	ZK 80	125	5/8"	12.200	A272812508018	1 2 3 4 5 6 7	■
SLTFLEX 125	ZK 120	125	M14	12.200	A272712512016	1 2 3 4 5 6 7	■
SLTFLEX 125	ZK 120	125	5/8"	12.200	A272812512018	1 2 3 4 5 6 7	■
SLTFLEX 178	ZKS 40	178	M14	8.500	A272917804018	1 2 3 4 5 6 7	■
SLTFLEX 178	ZKS 60	178	M14	8.500	A272917806018	1 2 3 4 5 6 7	■
SLTFLEX 178	ZKS 80	178	M14	8.500	A272917808018	1 2 3 4 5 6 7	■

Properties:

- high flexibility due to elongated flaps (no disturbing backing plate)
- simple tool change (backing plate / pad and mounting nut no longer required)
- long life



SLTO/SLTR, the powerful performer with the glass-fibre backing plate

Ordering example: A27231150401428

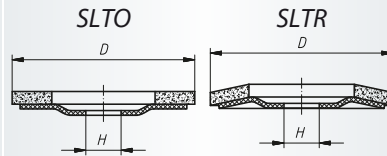

Packing unit:
10 pcs. per type
 v_{max} : 80 m/s
ISO 15635
Ceramic = ceramic grain
SLTO = flat
SLTR = dished

Description	Grits	D mm	H mm	n max. (1/min)	Product-Number	recommended for	
SLTO 115	Ceramic 40	115	22,23	13.300	A27251150401428	1 2 3 4 5 6 7 8	■
SLTO 125	Ceramic 40	125	22,23	12.200	A27251250401428	1 2 3 4 5 6 7 8	■
SLTO 125	Ceramic 60	125	22,23	12.200	A27251250601428	1 2 3 4 5 6 7 8	■
SLTO 125	Ceramic 80	125	22,23	12.200	A27251250801428	1 2 3 4 5 6 7 8	■
SLTR 115	Ceramic 40	115	22,23	13.300	A27231150401428	1 2 3 4 5 6 7 8	■
SLTR 115	Ceramic 60	115	22,23	13.300	A27231150601428	1 2 3 4 5 6 7 8	■
SLTR 115	Ceramic 80	115	22,23	13.300	A27231150801428	1 2 3 4 5 6 7 8	■
SLTR 125	Ceramic 40	125	22,23	12.200	A27231250401428	1 2 3 4 5 6 7 8	■
SLTR 125	Ceramic 60	125	22,23	12.200	A27231250601428	1 2 3 4 5 6 7 8	■
SLTR 125	Ceramic 80	125	22,23	12.200	A27231250801428	1 2 3 4 5 6 7 8	■
SLTR 178	Ceramic 40	178	22,23	8.500	A27231780401428	1 2 3 4 5 6 7 8	■



SLTO/SLTR, reinforced fibre backing

Ordering example: A27151000401423

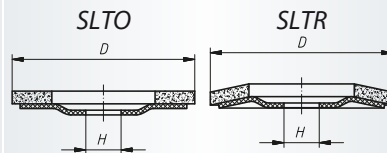

Packing unit:
10 pcs. per type
 v_{max} : 80 m/s
ISO 15635
ZK = Zirconia Alum. Oxide
NK = reg. Aluminium Oxide
SLTO = flat
SLTR = dished

Description	Grits	D mm	H mm	n max (1/min)	Product-Number	recommended for	
SLTO 100	ZK 40	100	16	15.300	A27151000401423	1 2 3 4 5 7	■
SLTO 100	ZK 60	100	16	15.300	A27151000601423	1 2 3 4 5 7	■
SLTO 100	ZK 80	100	16	15.300	A27151000801423	1 2 3 4 5 7	■
SLTO 115	NK 40	115	22,23	13.300	A27151150401400	1 2 3 4 5 6 7 8	■
SLTO 115	NK 60	115	22,23	13.300	A27151150601400	1 2 3 4 5 6 7 8	■
SLTO 115	NK 80	115	22,23	13.300	A27151150801400	1 2 3 4 5 6 7 8	■
SLTO 115	NK 120	115	22,23	13.300	A27151151201400	1 2 3 4 5 6 7 8	■
SLTO 115	ZK 36	115	22,23	13.300	A27151150361406	1 2 3 4 5 7	■
SLTO 115	ZK 40	115	22,23	13.300	A27151150401406	1 2 3 4 5 7	■
SLTO 115	ZK 50	115	22,23	13.300	A27151150501406	1 2 3 4 5 7	■
SLTO 115	ZK 60	115	22,23	13.300	A27151150601406	1 2 3 4 5 7	■
SLTO 115	ZK 80	115	22,23	13.300	A27151150801406	1 2 3 4 5 7	■
SLTO 115	ZK 120	115	22,23	13.300	A27151151201406	1 2 3 4 5 7	■



SLTO/SLTR, reinforced fibre backing

Ordering example: A27181780801400

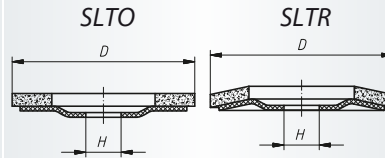

Packing unit:

10 pcs. per type

v_{max} : 80 m/s

ISO 15635

ZK = Zirconia Alum. Oxide

NK = reg. Aluminium Oxide

SLTO = flat

SLTR = dished

Description	Grits	D mm	H mm	n max (1/min)	Product-Number	recommended for	
SLTO 125	NK 40	125	22,23	12.200	A27151250401400	1 2 3 4 5 6 7 8	■
SLTO 125	NK 50	125	22,23	12.200	A27151250501400	1 2 3 4 5 6 7 8	■
SLTO 125	ZK 40	125	22,23	12.200	A27151250401406	1 2 3 4 5 7	■
SLTO 125	ZK 50	125	22,23	12.200	A27151250501406	1 2 3 4 5 7	■
SLTO 125	ZK 60	125	22,23	12.200	A27151250601406	1 2 3 4 5 7	■
SLTO 125	ZK 80	125	22,23	12.200	A27151250801406	1 2 3 4 5 7	■
SLTO 178	NK 60	178	22,23	8.500	A27151780601400	1 2 3 4 5 6 7 8	■
SLTO 178	ZK 36	178	22,23	8.500	A27151780361401	1 2 3 4 5 7	■
SLTO 178	ZK 40	178	22,23	8.500	A27151780401401	1 2 3 4 5 7	■
SLTO 178	ZK 60	178	22,23	8.500	A27151780601401	1 2 3 4 5 7	■
SLTO 178	ZK 80	178	22,23	8.500	A27151780801401	1 2 3 4 5 7	■
SLTO 178	ZK 120	178	22,23	8.500	A27151781201401	1 2 3 4 5 7	■
SLTR 100	ZK 40	100	16	15.300	A27181000401423	1 2 3 4 5 7	■
SLTR 100	ZK 60	100	16	15.300	A27181000601423	1 2 3 4 5 7	■
SLTR 100	ZK 80	100	16	15.300	A27181000801423	1 2 3 4 5 7	■
SLTR 115	NK 36	115	22,23	13.300	A27181150361400	1 2 3 4 5 6 7 8	■
SLTR 115	NK 40	115	22,23	13.300	A27181150401400	1 2 3 4 5 6 7 8	■
SLTR 115	NK 60	115	22,23	13.300	A27181150601400	1 2 3 4 5 6 7 8	■
SLTR 115	NK 80	115	22,23	13.300	A27181150801400	1 2 3 4 5 6 7 8	■
SLTR 115	NK 120	115	22,23	13.300	A27181151201400	1 2 3 4 5 6 7 8	■
SLTR 115	ZK 36	115	22,23	13.300	A27181150361406	1 2 3 4 5 7	■
SLTR 115	ZK 40	115	22,23	13.300	A27181150401406	1 2 3 4 5 7	■
SLTR 115	ZK 50	115	22,23	13.300	A27181150501406	1 2 3 4 5 7	■
SLTR 115	ZK 60	115	22,23	13.300	A27181150601406	1 2 3 4 5 7	■
SLTR 115	ZK 80	115	22,23	13.300	A27181150801406	1 2 3 4 5 7	■
SLTR 115	ZK 120	115	22,23	13.300	A27181151201406	1 2 3 4 5 7	■
SLTR 125	NK 40	125	22,23	12.200	A27181250401400	1 2 3 4 5 6 7 8	■
SLTR 125	NK 60	125	22,23	12.200	A27181250601400	1 2 3 4 5 6 7 8	■
SLTR 125	NK 80	125	22,23	12.200	A27181250801400	1 2 3 4 5 6 7 8	■
SLTR 125	NK 120	125	22,23	12.200	A27181251201400	1 2 3 4 5 6 7 8	■
SLTR 125	ZK 36	125	22,23	12.200	A27181250361406	1 2 3 4 5 7	■
SLTR 125	ZK 40	125	22,23	12.200	A27181250401406	1 2 3 4 5 7	■
SLTR 125	ZK 60	125	22,23	12.200	A27181250601406	1 2 3 4 5 7	■
SLTR 125	ZK 80	125	22,23	12.200	A27181250801406	1 2 3 4 5 7	■
SLTR 125	ZK 120	125	22,23	12.200	A27181251201406	1 2 3 4 5 7	■
SLTR 150	ZK 40	150	22,23	10.200	A27181500401416	1 2 3 4 5 7	■
SLTR 150	ZK 60	150	22,23	10.200	A27181500601416	1 2 3 4 5 7	■
SLTR 150	ZK 80	150	22,23	10.200	A27181500801416	1 2 3 4 5 7	■
SLTR 178	NK 40	178	22,23	8.500	A27181780401400	1 2 3 4 5 6 7 8	■
SLTR 178	NK 60	178	22,23	8.500	A27181780601400	1 2 3 4 5 6 7 8	■



Industry

SLTO/SLTR, reinforced fibre backing

Ordering example: A27181780801400

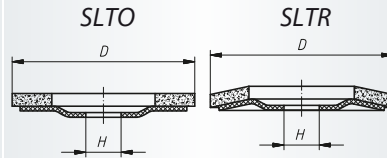

Packing unit:

10 pcs. per type

v_{max} : 80 m/s

ISO 15635

ZK = Zirconia Alum. Oxide

NK = reg. Aluminium Oxide

SLTO = flat

SLTR = dished

Description	Grits	D mm	H mm	n max (1/min)	Product-Number	recommended for	
SLTR 178	NK 80	178	22,23	8.500	A27181780801400	① ② ③ ④ ⑤ ⑥ ⑦ ⑧	■
SLTR 178	ZK 36	178	22,23	8.500	A27181780361401	① ② ③ ④ ⑤ ⑦	■
SLTR 178	ZK 40	178	22,23	8.500	A27181780401401	① ② ③ ④ ⑤ ⑦	■
SLTR 178	ZK 60	178	22,23	8.500	A27181780601401	① ② ③ ④ ⑤ ⑦	■
SLTR 178	ZK 80	178	22,23	8.500	A27181780801401	① ② ③ ④ ⑤ ⑦	■
SLTR 178	ZK 120	178	22,23	8.500	A27181781201401	① ② ③ ④ ⑤ ⑦	■



SLTO/SLTR competitively priced BASE-X, reinforced fibre backing

Ordering example: A27151000401501

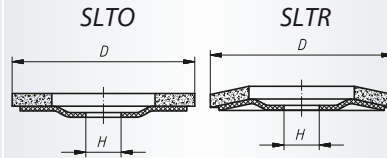

Packing unit:

10 pcs. per type

v_{max} : 80 m/s

ISO 15635

ZK = Zirconia Alum. Oxide

SLTO = flat

SLTR = dished

Description	Grits	D mm	H mm	n max (1/min)	Product-Number	recommended for									
SLTO 100 BASE-X	ZK 40	100	16	15.300	A27151000401501	1	2	3	4	5	7				■
SLTO 100 BASE-X	ZK 60	100	16	15.300	A27151000601501	1	2	3	4	5	7				■
SLTO 100 BASE-X	ZK 80	100	16	15.300	A27151000801501	1	2	3	4	5	7				■
SLTO 100 BASE-X	ZK 120	100	16	15.300	A27151001201501	1	2	3	4	5	7				■
SLTO 115 BASE-X	ZK 40	115	22,23	13.300	A27151150401501	1	2	3	4	5	7				■
SLTO 115 BASE-X	ZK 60	115	22,23	13.300	A27151150601501	1	2	3	4	5	7				■
SLTO 115 BASE-X	ZK 80	115	22,23	13.300	A27151150801501	1	2	3	4	5	7				■
SLTO 115 BASE-X	ZK 120	115	22,23	13.300	A27151151201501	1	2	3	4	5	7				■
SLTO 125 BASE-X	ZK 40	125	22,23	12.200	A27151250401501	1	2	3	4	5	7				■
SLTO 125 BASE-X	ZK 60	125	22,23	12.200	A27151250601501	1	2	3	4	5	7				■
SLTO 125 BASE-X	ZK 80	125	22,23	12.200	A27151250801501	1	2	3	4	5	7				■
SLTO 178 BASE-X	ZK 40	178	22,23	8.500	A27151780401501	1	2	3	4	5	7				■
SLTO 178 BASE-X	ZK 60	178	22,23	8.500	A27151780601501	1	2	3	4	5	7				■
SLTO 178 BASE-X	ZK 80	178	22,23	8.500	A27151780801501	1	2	3	4	5	7				■
SLTR 100 BASE-X	ZK 40	100	16	15.300	A27181000401501	1	2	3	4	5	7				■
SLTR 100 BASE-X	ZK 60	100	16	15.300	A27181000601501	1	2	3	4	5	7				■
SLTR 100 BASE-X	ZK 80	100	16	15.300	A27181000801501	1	2	3	4	5	7				■
SLTR 100 BASE-X	ZK 120	100	16	15.300	A27181001201501	1	2	3	4	5	7				■
SLTR 115 BASE-X	ZK 40	115	22,23	13.300	A27181150401501	1	2	3	4	5	7				■
SLTR 115 BASE-X	ZK 60	115	22,23	13.300	A27181150601501	1	2	3	4	5	7				■
SLTR 115 BASE-X	ZK 80	115	22,23	13.300	A27181150801501	1	2	3	4	5	7				■
SLTR 115 BASE-X	ZK 100	115	22,23	13.300	A27181151001501	1	2	3	4	5	7				■
SLTR 125 BASE-X	ZK 40	125	22,23	12.200	A27181250401501	1	2	3	4	5	7				■
SLTR 125 BASE-X	ZK 60	125	22,23	12.200	A27181250601501	1	2	3	4	5	7				■
SLTR 125 BASE-X	ZK 80	125	22,23	12.200	A27181250801501	1	2	3	4	5	7				■
SLTR 178 BASE-X	ZK 40	178	22,23	8.500	A27181780401501	1	2	3	4	5	7				■
SLTR 178 BASE-X	ZK 60	178	22,23	8.500	A27181780601501	1	2	3	4	5	7				■
SLTR 178 BASE-X	ZK 80	178	22,23	8.500	A27181780801501	1	2	3	4	5	7				■
SLTR 178 BASE-X	ZK 120	178	22,23	8.500	A27181781201501	1	2	3	4	5	7				■



High Performance

The SLTZ, with special active grinding additives

Ordering example: A27261150401418

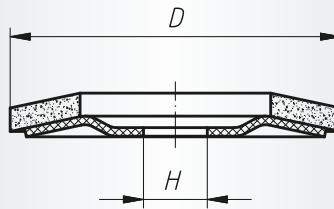

Packing unit:

10 pcs. per type

v_{max} : 80 m/s

ISO 15635

ZKS = Zirconia Alum. Oxide
with special coating containing active
grinding additives

SLTZ = dished

Description	Grits	D mm	H mm	n max (1/min)	Product-Number	recommended for	
SLTZ 115	ZKS 40	115	22,23	13.300	A27261150401418	2 3 4 5 7	■
SLTZ 115	ZKS 60	115	22,23	13.300	A27261150601418	2 3 4 5 7	■
SLTZ 115	ZKS 80	115	22,23	13.300	A27261150801418	2 3 4 5 7	■
SLTZ 125	ZKS 40	125	22,23	12.200	A27261250401418	2 3 4 5 7	■
SLTZ 125	ZKS 60	125	22,23	12.200	A27261250601418	2 3 4 5 7	■
SLTZ 125	ZKS 80	125	22,23	12.200	A27261250801418	2 3 4 5 7	■

Properties:

- high quality coated abrasive containing special active grinding additives
- top grinding performance
- outstanding tool life

Applicaton:

- shipbuilding
- steel construction work
- stainless steel
- and many other applications

Characteristics:

- suitable for most materials
- can be used for deburring, fettling, derusting and finishing



Industry

The SLTS, with flexible flaps

Ordering example: A27391150401423

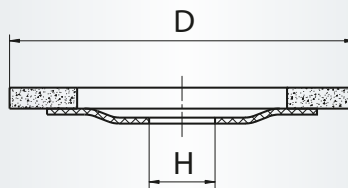

Packing unit:

10 pcs. per type

v_{max} : 80 m/s

ZK = Zirconia Alum. Oxide

SLTS = flat

Description	Grits	D mm	H mm	n max. (1/min)	Product-Number	recommended for	
SLTS 115	ZK 40	115	22,23	13.300	A27391150401423	1 2 3 4 5 7	■
SLTS 115	ZK 60	115	22,23	13.300	A27391150601423	1 2 3 4 5 7	■
SLTS 115	ZK 80	115	22,23	13.300	A27391150801423	1 2 3 4 5 7	■
SLTS 125	ZK 40	125	22,23	12.200	A27391250401423	1 2 3 4 5 7	■
SLTS 125	ZK 60	125	22,23	12.200	A27391250601423	1 2 3 4 5 7	■
SLTS 125	ZK 80	125	22,23	12.200	A27391250801423	1 2 3 4 5 7	■

Due to the flexible flap configuration, the SLTS has a universal application particularly where a "soft" grinding action is required to avoid damage to the

workpiece. The SLTS is used on similar applications which require a fibre discs; in addition, it is ideally suited to grind radii or corners.





SLTB/SLTF – The robust with steel backing

Ordering example: A2250115120

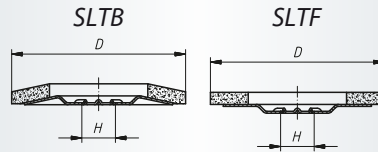

Packing unit:

10 pcs. per type

v_{max} : 80 m/s

ISO 15635

ZK = Zirconia Alum. Oxide

NK = reg. Aluminium Oxide

SLTF = flat

SLTB = dished

Description	Grits	D mm	H mm	n max (1/min)	Product-Number	recommended for										
SLTB 115	ZK 36	115	22,23	13.300	A2250115030	1	2	3	4	5		7				■
SLTB 115	ZK 40	115	22,23	13.300	A2250115040	1	2	3	4	5		7				■
SLTB 115	ZK 50	115	22,23	13.300	A2250115050	1	2	3	4	5		7				■
SLTB 115	ZK 60	115	22,23	13.300	A2250115060	1	2	3	4	5		7				■
SLTB 115	ZK 80	115	22,23	13.300	A2250115080	1	2	3	4	5		7				■
SLTB 115	NK 120	115	22,23	13.300	A2250115120	1	2	3	4	5	6	7	8			■
SLTB 125	ZK 40	125	22,23	12.200	A2250125040	1	2	3	4	5		7				■
SLTB 125	ZK 60	125	22,23	12.200	A2250125060	1	2	3	4	5		7				■
SLTB 125	ZK 80	125	22,23	12.200	A2250125080	1	2	3	4	5		7				■
SLTB 178	ZK 40	178	22,23	8.500	A2250178040	1	2	3	4	5		7				■
SLTB 178	ZK 60	178	22,23	8.500	A2250178060	1	2	3	4	5		7				■
SLTB 178	ZK 80	178	22,23	8.500	A2250178080	1	2	3	4	5		7				■
SLTF 115	ZK 40	115	22,23	13.300	A2251115040	1	2	3	4	5		7				■
SLTF 115	ZK 60	115	22,23	13.300	A2251115060	1	2	3	4	5		7				■
SLTF 115	ZK 80	115	22,23	13.300	A2251115080	1	2	3	4	5		7				■
SLTF 115	NK 120	115	22,23	13.300	A2251115120	1	2	3	4	5	6	7	8			■
SLTF 125	ZK 40	125	22,23	12.200	A2251125040	1	2	3	4	5		7				■
SLTF 125	ZK 60	125	22,23	12.200	A2251125060	1	2	3	4	5		7				■
SLTF 125	ZK 80	125	22,23	12.200	A2251125080	1	2	3	4	5		7				■
SLTF 178	ZK 40	178	22,23	8.500	A2251178040	1	2	3	4	5		7				■
SLTF 178	ZK 60	178	22,23	8.500	A2251178060	1	2	3	4	5		7				■



Industry

SLTK, made of plastic with space for cooling

Ordering example: A27111150401623

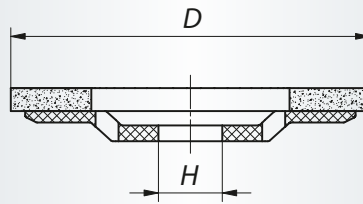

Packing unit:
10 pcs. per type
 v_{max} : 80 m/s
ISO 15635
ZK = Zirconia Alum. Oxide
SLTK = flat

Description	Grits	D mm	H mm	n max (1/min)	Product-Number	recommended for		
SLTK 115	ZK 40	115	22,23	13.300	A27111150401623	1 2 3 4 5 7	■	NEW
SLTK 115	ZK 60	115	22,23	13.300	A27111150601623	1 2 3 4 5 7	■	NEW
SLTK 125	ZK 40	125	22,23	12.200	A27111250401623	1 2 3 4 5 7	■	NEW
SLTK 125	ZK 60	125	22,23	12.200	A27111250601623	1 2 3 4 5 7	■	NEW

The plastic carrier will not leave any abrasive wear on the workpiece.
Now with integrated cooling slots.



Industry

SLTK with cooling and quick-release screw thread

Ordering example: A27111150401723

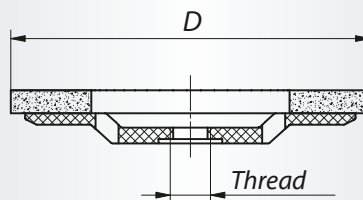

Packing unit:
10 pcs. per type
 v_{max} : 80 m/s
ISO 15635
ZK = Zirconia Alum. Oxide
SLTK = flat

Description	Grits	D mm	Thread	n max (1/min)	Product-Number	recommended for		
SLTK 115	ZK 40	115	M14	13.300	A27111150401723	1 2 3 4 5 7	■	NEW
SLTK 115	ZK 60	115	M14	13.300	A27111150601723	1 2 3 4 5 7	■	NEW
SLTK 125	ZK 40	125	M14	12.200	A27111250401723	1 2 3 4 5 7	■	NEW
SLTK 125	ZK 60	125	M14	12.200	A27111250601723	1 2 3 4 5 7	■	NEW

The plastic carrier will not leave any abrasive wear on the workpiece. With M14 screw thread for simple mounting onto the angle grinder. Now with integrated cooling slots.



The NAWAROFLEX® with the backing plate made of renewable raw materials

Ordering example: A27031150360127

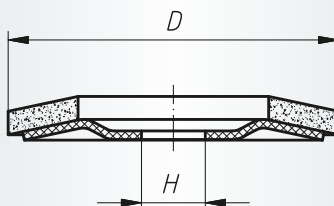

Packing unit:

10 pcs. per type

v_{max} : 80 m/s

ISO 15635

ZKS = Zirconia Alum. Oxide
with special coating containing active grinding additives

SLTC = dished

Description	Grits	D mm	H mm	n max. (1/min)	Product-Number	recommended for	
SLTC 115	ZKS 36	115	22,23	13.300	A27031150360127	2 3 4 5 7	■
SLTC 115	ZKS 40	115	22,23	13.300	A27031150400127	2 3 4 5 7	■
SLTC 115	ZKS 50	115	22,23	13.300	A27031150500127	2 3 4 5 7	■
SLTC 115	ZKS 60	115	22,23	13.300	A27031150600127	2 3 4 5 7	■
SLTC 115	ZKS 80	115	22,23	13.300	A27031150800127	2 3 4 5 7	■
SLTC 125	ZKS 40	125	22,23	12.200	A27031250400127	2 3 4 5 7	■
SLTC 125	ZKS 60	125	22,23	12.200	A27031250600127	2 3 4 5 7	■
SLTC 125	ZKS 80	125	22,23	12.200	A27031250800127	2 3 4 5 7	■

Type with special zirconia alum. oxide material (polyester based) and a coating of active grinding additives.

Ideally suited for stainless steel.



The NAWAROFLEX® – to improve surface finish

Ordering example: A27131151040140

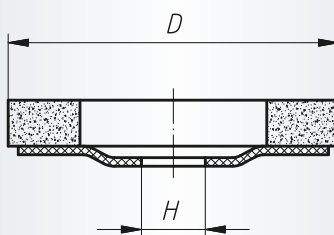

Packing unit:

10 pcs. per type

v_{max} : 30 m/s

ISO 15635

A = Abrasive fleece/abrasive cloth combined Al.-Oxide

C = Abrasive fleece/abrasive cloth combined Sil.-Carbide

SLTM = flat

Description	Grits	D mm	H mm	n max. (1/min)	Product-Number	recommended for	
SLTM 115	A 104/80	115	22,23	4.900	A27131151040140	1 2 3 4 5 6 7 8	■
SLTM 115	A 106/150	115	22,23	4.900	A27131151060140	1 2 3 4 5 6 7 8	■
SLTM 115	A 107/240	115	22,23	4.900	A27131151070140	1 2 3 4 5 6 7 8	■
SLTM 115	C 204/80	115	22,23	4.900	A27131152040141	1 2 3 4 5 6 7 8 9	■
SLTM 115	C 206/150	115	22,23	4.900	A27131152060141	1 2 3 4 5 6 7 8 9	■
SLTM 115	C 207/240	115	22,23	4.900	A27131152070141	1 2 3 4 5 6 7 8 9	■

Usable without supporting-plate on adjustable and slow-speed angle grinders.



Industry

The NAWAROFLEX® – for finishing and polishing

Ordering example: A27221151040130

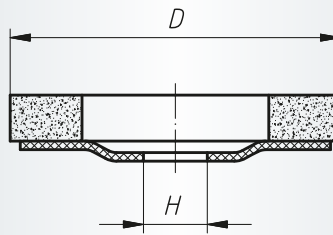

Packing unit:

10 pcs. per type

v_{max} : 30 m/s

A = Abrasive fleece cloth combined

Al.-Oxide

C = Abrasive fleece cloth combined Sil.-Carbide

SLTV = flat

Description	Grits	D mm	H mm	n max. (1/min)	Product-Number	recommended for	
SLTV 115	A 104	115	22,23	4.900	A27221151040130	① ② ③ ④ ⑤ ⑥ ⑦ ⑧	■
SLTV 115	A 106	115	22,23	4.900	A27221151060130	① ② ③ ④ ⑤ ⑥ ⑦ ⑧	■
SLTV 115	A 107	115	22,23	4.900	A27221151070130	① ② ③ ④ ⑤ ⑥ ⑦ ⑧	■
SLTV 115	C 206	115	22,23	4.900	A27221152060130	① ② ③ ④ ⑤ ⑥ ⑦ ⑧ ⑨	■
SLTV 115	C 207	115	22,23	4.900	A27221152070130	① ② ③ ④ ⑤ ⑥ ⑦ ⑧ ⑨	■

Usable without supporting-plate on adjustable and slow-speed angle grinders.



Industry

The SLTP, Polishing disc

Ordering example: A271611523

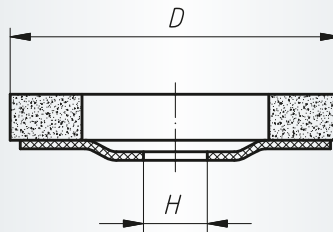
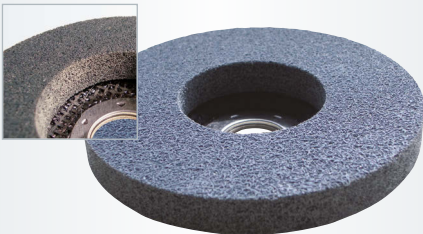

Packing unit:

5 pcs. per type

v_{max} : 50 m/s

SLTP = dishd

Description	Quality	D mm	H mm	reinforced hartness	n max. (1/min)	Product-Number	recommended for	
SLTP 115 M	SIC fine	115	22,23	medium	8.350	A271611523	① ② ③ ④ ⑤ ⑥ ⑦ ⑧	■
SLTP 115 W	SIC fine	115	22,23	soft	8.350	A271611513	① ② ③ ④ ⑤ ⑥ ⑦ ⑧	■

Ideal for working on stainless steel, aluminium and other non ferrous metals.

With the SLTP deburring, cleaning and polishing applications could be accomplished.

The fleece fibre construction avoids the clogging of this tool.

The high tool life and the less edge abrasion enhance the efficiency.

Usable without supporting-plate on adjustable and slow-speed angle grinders.

Safe. Precise. Perfect.

A cut above the rest!

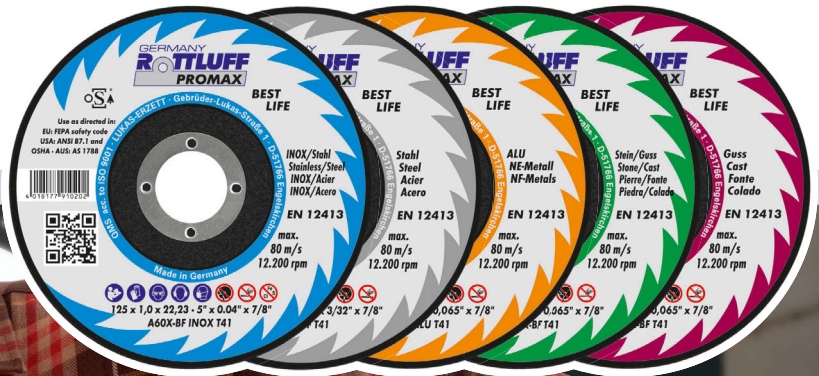

Test our quality cutting discs and tell us what you think!



Mounted flap wheels of abrasive cloth

228 Qualities and Applications

260 General Information

261 Mounted flap wheels of abrasive cloth, recessed

261 Mounted flap wheels of abrasive cloth

268 Mounted flap wheels of abrasive cloth, slotted

269 Mounted flap wheels of abrasive cloth, SFE

270 Mounted flap wheels of abrasive cloth, SFC

271 Mounted flap wheels with internal thread

272 Mounted flap wheels with threaded shank

273 Mini-Flap wheels of abrasive cloth

381 Air tools

Product line marking

Product lines are labelled in the table header with the appropriate tabs. Further information on page **14** and **15**.

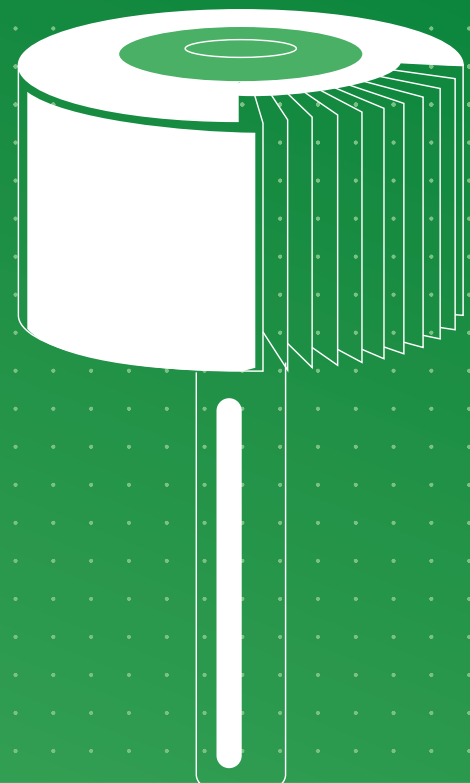

Information

SFL, mounted flap wheels of abrasive cloth

These tools consist of individual flaps radially located around the hub of the tool; they are mainly used in hand-held power tools.

We offer our coated abrasive flap wheels in various qualities i.e. NK, NKE and SIC.

Examples of application:

- finishing
- derusting
- fettling
- deburring
- surface grinding
- decorative finishing
- bevelling

SFB, Mounted flap wheels of abrasive cloth, slotted

By slotting the lamellas on the periphery, the flexibility of this type of mounted flap wheel is increased. The slotted flap wheel quickly profiles itself to the contour of the workpiece.

SFT, Mounted flap wheels of abrasive cloth, recessed

These tools are suitable for face and peripheral grinding.

Adaptor for SFI and SFA

These adaptors extend the shank length and optimise down-time. Tool change is made without removing the adaptor from the machine.



High Performance

SFT, Flap wheels – recessed

Ordering example: A3100040306060

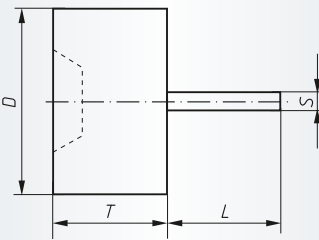
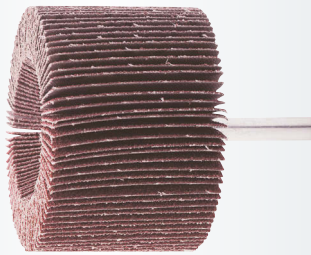

Packing unit:

10 pcs. per type

Further dimensions, qualities

and shank lengths on request

NK = reg. Aluminium Oxide

Description	Grits	D mm	T mm	S mm	L mm	n recom. (1/min)	n max. (1/min)	Product-Number	recommended for	
SFT 04030.06	NK 60	40	30	6	40	12.000	19.100	A3100040306060	① ② ③ ④ ⑤ ⑥ ⑦ ⑧	■
SFT 04030.06	NK 80	40	30	6	40	12.000	19.100	A3100040306080	① ② ③ ④ ⑤ ⑥ ⑦ ⑧	■
SFT 04030.06	NK 150	40	30	6	40	12.000	19.100	A3100040306150	① ② ③ ④ ⑤ ⑥ ⑦ ⑧	■
SFT 06040.06	NK 60	60	40	6	40	8.000	12.700	A3100060406060	① ② ③ ④ ⑤ ⑥ ⑦ ⑧	■
SFT 06040.06	NK 80	60	40	6	40	8.000	12.700	A3100060406080	① ② ③ ④ ⑤ ⑥ ⑦ ⑧	■
SFT 06040.06	NK 150	60	40	6	40	8.000	12.700	A3100060406150	① ② ③ ④ ⑤ ⑥ ⑦ ⑧	■

The stated maximum operating speed only applies to a maximum overhang

L_0 of 20 mm. Other overhang dimensions must be calculated separately.

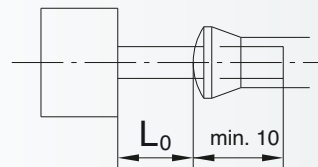

Industry

SFL, Flap wheels

Ordering example: A2200010103080

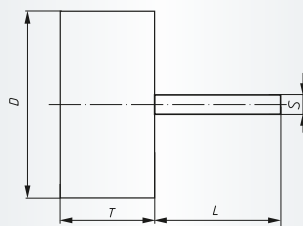
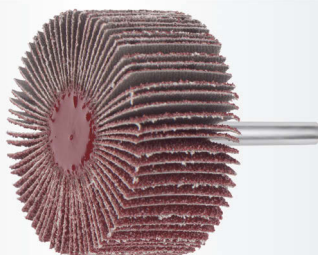

Packing unit:

10 pcs. per type

Further dimensions, qualities

and shank lengths on request

NK = reg. Aluminium Oxide

Description	Grits	D mm	T mm	S mm	L mm	n recom. (1/min)	n max. (1/min)	Product-Number	recommended for	
SFL 01010.03	NK 80	10	10	3	40	26.000	35.000	A2200010103080	① ② ③ ④ ⑤ ⑥ ⑦ ⑧	■
SFL 01010.03	NK 120	10	10	3	40	26.000	35.000	A2200010103120	① ② ③ ④ ⑤ ⑥ ⑦ ⑧	■
SFL 01010.03	NK 150	10	10	3	40	26.000	35.000	A2200010103150	① ② ③ ④ ⑤ ⑥ ⑦ ⑧	■
SFL 01010.03	NK 240	10	10	3	40	26.000	35.000	A2200010103240	① ② ③ ④ ⑤ ⑥ ⑦ ⑧	■
SFL 01015.03	NK 80	10	15	3	40	24.000	35.000	A2200010153080	① ② ③ ④ ⑤ ⑥ ⑦ ⑧	■
SFL 01510.03	NK 80	15	10	3	40	24.000	35.000	A2200015103080	① ② ③ ④ ⑤ ⑥ ⑦ ⑧	■
SFL 01510.03	NK 150	15	10	3	40	24.000	35.000	A2200015103150	① ② ③ ④ ⑤ ⑥ ⑦ ⑧	■
SFL 01515.03	NK 80	15	15	3	40	24.000	35.000	A2200015153080	① ② ③ ④ ⑤ ⑥ ⑦ ⑧	■
SFL 01515.03	NK 120	15	15	3	40	24.000	35.000	A2200015153120	① ② ③ ④ ⑤ ⑥ ⑦ ⑧	■
SFL 01515.03	NK 150	15	15	3	40	24.000	35.000	A2200015153150	① ② ③ ④ ⑤ ⑥ ⑦ ⑧	■
SFL 02005.06	NK 120	20	5	6	40	20.000	38.200	A2200020056120	① ② ③ ④ ⑤ ⑥ ⑦ ⑧	■
SFL 02010.03	NK 80	20	10	3	40	20.000	28.000	A2200020103080	① ② ③ ④ ⑤ ⑥ ⑦ ⑧	■

262 Mounted flap wheels of abrasive cloth



Industry

SFL, Flap wheels

Ordering example: A2200020103120

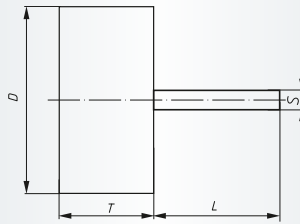
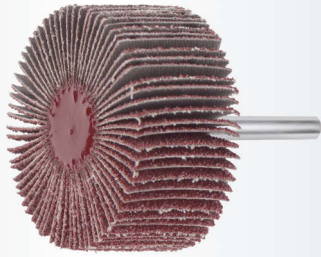

Packing unit:

10 pcs. per type

Further dimensions, qualities

and shank lengths on request

NK = reg. Aluminium Oxide

Description	Grits	D mm	T mm	S mm	L mm	n recom. (1/min)	n max. (1/min)	Product-Number	recommended for	
SFL 02010.03	NK 120	20	10	3	40	20.000	28.000	A2200020103120	① ② ③ ④ ⑤ ⑥ ⑦ ⑧	■
SFL 02010.03	NK 150	20	10	3	40	20.000	28.000	A2200020103150	① ② ③ ④ ⑤ ⑥ ⑦ ⑧	■
SFL 02010.03	NK 320	20	10	3	40	20.000	28.000	A2200020103320	① ② ③ ④ ⑤ ⑥ ⑦ ⑧	■
SFL 02010.06	NK 80	20	10	6	40	20.000	38.200	A2200020106080	① ② ③ ④ ⑤ ⑥ ⑦ ⑧	■
SFL 02010.06	NK 120	20	10	6	40	20.000	38.200	A2200020106120	① ② ③ ④ ⑤ ⑥ ⑦ ⑧	■
SFL 02015.06	NK 60	20	15	6	40	20.000	38.200	A2200020156060	① ② ③ ④ ⑤ ⑥ ⑦ ⑧	■
SFL 02015.06	NK 80	20	15	6	40	20.000	38.200	A2200020156080	① ② ③ ④ ⑤ ⑥ ⑦ ⑧	■
SFL 02015.06	NK 120	20	15	6	40	20.000	38.200	A2200020156120	① ② ③ ④ ⑤ ⑥ ⑦ ⑧	■
SFL 02015.06	NK 150	20	15	6	40	20.000	38.200	A2200020156150	① ② ③ ④ ⑤ ⑥ ⑦ ⑧	■
SFL 02015.06	NK 240	20	15	6	40	20.000	38.200	A2200020156240	① ② ③ ④ ⑤ ⑥ ⑦ ⑧	■
SFL 02020.06	NK 80	20	20	6	40	20.000	38.200	A2200020206080	① ② ③ ④ ⑤ ⑥ ⑦ ⑧	■
SFL 02505.03	NK 120	25	5	3	40	16.000	18.000	A2200025053120	① ② ③ ④ ⑤ ⑥ ⑦ ⑧	■
SFL 02510.03	NK 80	25	10	3	40	16.000	18.000	A2200025103080	① ② ③ ④ ⑤ ⑥ ⑦ ⑧	■
SFL 02510.03	NK 120	25	10	3	40	16.000	18.000	A2200025103120	① ② ③ ④ ⑤ ⑥ ⑦ ⑧	■
SFL 02510.03	NK 150	25	10	3	40	16.000	18.000	A2200025103150	① ② ③ ④ ⑤ ⑥ ⑦ ⑧	■
SFL 02510.06	NK 80	25	10	6	40	16.000	30.600	A2200025106080	① ② ③ ④ ⑤ ⑥ ⑦ ⑧	■
SFL 02510.06	NK 120	25	10	6	40	16.000	30.600	A2200025106120	① ② ③ ④ ⑤ ⑥ ⑦ ⑧	■
SFL 02515.06	NK 80	25	15	6	40	16.000	30.600	A2200025156080	① ② ③ ④ ⑤ ⑥ ⑦ ⑧	■
SFL 02515.06	NK 120	25	15	6	40	16.000	30.600	A2200025156120	① ② ③ ④ ⑤ ⑥ ⑦ ⑧	■
SFL 02515.06	NK 150	25	15	6	40	16.000	30.600	A2200025156150	① ② ③ ④ ⑤ ⑥ ⑦ ⑧	■
SFL 02520.06	NK 80	25	20	6	40	16.000	30.600	A2200025206080	① ② ③ ④ ⑤ ⑥ ⑦ ⑧	■
SFL 02520.06	NK 120	25	20	6	40	16.000	30.600	A2200025206120	① ② ③ ④ ⑤ ⑥ ⑦ ⑧	■
SFL 02525.06	NK 80	25	25	6	40	16.000	30.600	A2200025256080	① ② ③ ④ ⑤ ⑥ ⑦ ⑧	■
SFL 02525.06	NK 150	25	25	6	40	16.000	30.600	A2200025256150	① ② ③ ④ ⑤ ⑥ ⑦ ⑧	■
SFL 03005.03	NK 60	30	5	3	40	16.000	18.000	A2200030053060	① ② ③ ④ ⑤ ⑥ ⑦ ⑧	■
SFL 03005.03	NK 80	30	5	3	40	16.000	18.000	A2200030053080	① ② ③ ④ ⑤ ⑥ ⑦ ⑧	■
SFL 03005.03	NK 120	30	5	3	40	16.000	18.000	A2200030053120	① ② ③ ④ ⑤ ⑥ ⑦ ⑧	■
SFL 03005.03	NK 150	30	5	3	40	16.000	18.000	A2200030053150	① ② ③ ④ ⑤ ⑥ ⑦ ⑧	■
SFL 03005.03	NK 240	30	5	3	40	16.000	18.000	A2200030053240	① ② ③ ④ ⑤ ⑥ ⑦ ⑧	■
SFL 03005.03	NK 320	30	5	3	40	16.000	18.000	A2200030053320	① ② ③ ④ ⑤ ⑥ ⑦ ⑧	■
SFL 03005.06	NK 60	30	5	6	40	16.000	25.400	A2200030056060	① ② ③ ④ ⑤ ⑥ ⑦ ⑧	■
SFL 03005.06	NK 80	30	5	6	40	16.000	25.400	A2200030056080	① ② ③ ④ ⑤ ⑥ ⑦ ⑧	■

The stated maximum operating speed only applies to a maximum overhang L_0 of 20 mm. Other overhang dimensions must be calculated separately.

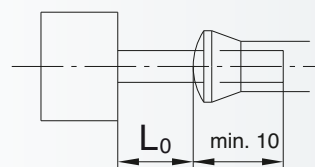



Industry

SFL, Flap wheels

Ordering example: A2200030056120

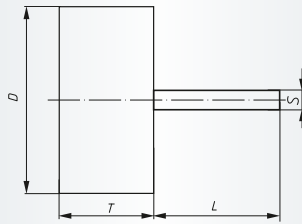
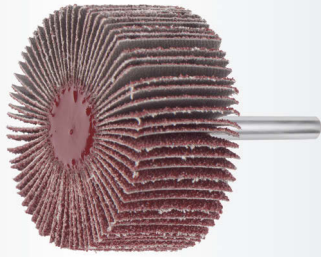

Packing unit:

10 pcs. per type

Further dimensions, qualities

and shank lengths on request

NK = reg. Aluminium Oxide

Description	Grits	D mm	T mm	S mm	L mm	n recom. (1/min)	n max. (1/min)	Product-Number	recommended for	
SFL 03005.06	NK 120	30	5	6	40	16.000	25.400	A2200030056120	① ② ③ ④ ⑤ ⑥ ⑦ ⑧	■
SFL 03005.06	NK 150	30	5	6	40	16.000	25.400	A2200030056150	① ② ③ ④ ⑤ ⑥ ⑦ ⑧	■
SFL 03005.06	NK 240	30	5	6	40	16.000	25.400	A2200030056240	① ② ③ ④ ⑤ ⑥ ⑦ ⑧	■
SFL 03005.06	NK 320	30	5	6	40	16.000	25.400	A2200030056320	① ② ③ ④ ⑤ ⑥ ⑦ ⑧	■
SFL 03010.03	NK 60	30	10	3	40	16.000	18.000	A2200030103060	① ② ③ ④ ⑤ ⑥ ⑦ ⑧	■
SFL 03010.03	NK 80	30	10	3	40	16.000	18.000	A2200030103080	① ② ③ ④ ⑤ ⑥ ⑦ ⑧	■
SFL 03010.03	NK 120	30	10	3	40	16.000	18.000	A2200030103120	① ② ③ ④ ⑤ ⑥ ⑦ ⑧	■
SFL 03010.03	NK 150	30	10	3	40	16.000	18.000	A2200030103150	① ② ③ ④ ⑤ ⑥ ⑦ ⑧	■
SFL 03010.03	NK 240	30	10	3	40	16.000	18.000	A2200030103240	① ② ③ ④ ⑤ ⑥ ⑦ ⑧	■
SFL 03010.03	NK 320	30	10	3	40	16.000	18.000	A2200030103320	① ② ③ ④ ⑤ ⑥ ⑦ ⑧	■
SFL 03010.06	NK 60	30	10	6	40	16.000	25.400	A2200030106060	① ② ③ ④ ⑤ ⑥ ⑦ ⑧	■
SFL 03010.06	NK 80	30	10	6	40	16.000	25.400	A2200030106080	① ② ③ ④ ⑤ ⑥ ⑦ ⑧	■
SFL 03010.06	NK 120	30	10	6	40	16.000	25.400	A2200030106120	① ② ③ ④ ⑤ ⑥ ⑦ ⑧	■
SFL 03010.06	NK 150	30	10	6	40	16.000	25.400	A2200030106150	① ② ③ ④ ⑤ ⑥ ⑦ ⑧	■
SFL 03010.06	NK 240	30	10	6	40	16.000	25.400	A2200030106240	① ② ③ ④ ⑤ ⑥ ⑦ ⑧	■
SFL 03010.06	NK 320	30	10	6	40	16.000	25.400	A2200030106320	① ② ③ ④ ⑤ ⑥ ⑦ ⑧	■
SFL 03015.06	NK 60	30	15	6	40	16.000	25.400	A2200030156060	① ② ③ ④ ⑤ ⑥ ⑦ ⑧	■
SFL 03015.06	NK 80	30	15	6	40	16.000	25.400	A2200030156080	① ② ③ ④ ⑤ ⑥ ⑦ ⑧	■
SFL 03015.06	NK 120	30	15	6	40	16.000	25.400	A2200030156120	① ② ③ ④ ⑤ ⑥ ⑦ ⑧	■
SFL 03015.06	NK 150	30	15	6	40	16.000	25.400	A2200030156150	① ② ③ ④ ⑤ ⑥ ⑦ ⑧	■
SFL 03020.06	NK 40	30	20	6	40	16.000	25.400	A2200030206040	① ② ③ ④ ⑤ ⑥ ⑦ ⑧	■
SFL 03020.06	NK 60	30	20	6	40	16.000	25.400	A2200030206060	① ② ③ ④ ⑤ ⑥ ⑦ ⑧	■
SFL 03020.06	NK 80	30	20	6	40	16.000	25.400	A2200030206080	① ② ③ ④ ⑤ ⑥ ⑦ ⑧	■
SFL 03020.06	NK 120	30	20	6	40	16.000	25.400	A2200030206120	① ② ③ ④ ⑤ ⑥ ⑦ ⑧	■
SFL 04010.03	NK 60	40	10	3	40	12.000	14.000	A2200040103060	① ② ③ ④ ⑤ ⑥ ⑦ ⑧	■
SFL 04010.03	NK 80	40	10	3	40	12.000	14.000	A2200040103080	① ② ③ ④ ⑤ ⑥ ⑦ ⑧	■
SFL 04010.03	NK 120	40	10	3	40	12.000	14.000	A2200040103120	① ② ③ ④ ⑤ ⑥ ⑦ ⑧	■
SFL 04010.03	NK 150	40	10	3	40	12.000	14.000	A2200040103150	① ② ③ ④ ⑤ ⑥ ⑦ ⑧	■
SFL 04010.06	NK 60	40	10	6	40	12.000	19.100	A2200040106060	① ② ③ ④ ⑤ ⑥ ⑦ ⑧	■
SFL 04010.06	NK 80	40	10	6	40	12.000	19.100	A2200040106080	① ② ③ ④ ⑤ ⑥ ⑦ ⑧	■
SFL 04010.06	NK 120	40	10	6	40	12.000	19.100	A2200040106120	① ② ③ ④ ⑤ ⑥ ⑦ ⑧	■
SFL 04010.06	NK 150	40	10	6	40	12.000	19.100	A2200040106150	① ② ③ ④ ⑤ ⑥ ⑦ ⑧	■

The stated maximum operating speed only applies to a maximum overhang L_0 of 20 mm. Other overhang dimensions must be calculated separately.

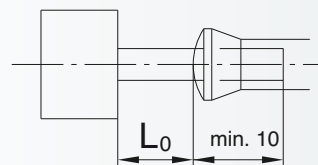



SFL, Flap wheels

Ordering example: A2200040106240

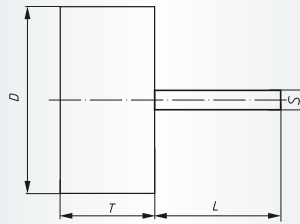
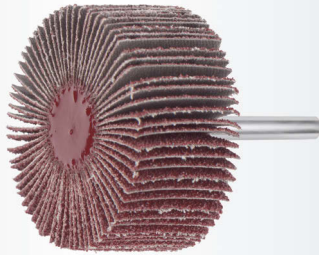

Packing unit:

10 pcs. per type

Further dimensions, qualities

and shank lengths on request

NK = reg. Aluminium Oxide

Description	Grits	D mm	T mm	S mm	L mm	n recom. (1/min)	n max. (1/min)	Product-Number	recommended for	
SFL 04010.06	NK 240	40	10	6	40	12.000	19.100	A2200040106240	1 2 3 4 5 6 7 8	■
SFL 04010.06	NK 320	40	10	6	40	12.000	19.100	A2200040106320	1 2 3 4 5 6 7 8	■
SFL 04015.06	NK 40	40	15	6	40	12.000	19.100	A2200040156040	1 2 3 4 5 6 7 8	■
SFL 04015.06	NK 60	40	15	6	40	12.000	19.100	A2200040156060	1 2 3 4 5 6 7 8	■
SFL 04015.06	NK 80	40	15	6	40	12.000	19.100	A2200040156080	1 2 3 4 5 6 7 8	■
SFL 04015.06	NK 120	40	15	6	40	12.000	19.100	A2200040156120	1 2 3 4 5 6 7 8	■
SFL 04015.06	NK 150	40	15	6	40	12.000	19.100	A2200040156150	1 2 3 4 5 6 7 8	■
SFL 04015.06	NK 240	40	15	6	40	12.000	19.100	A2200040156240	1 2 3 4 5 6 7 8	■
SFL 04015.06	NK 320	40	15	6	40	12.000	19.100	A2200040156320	1 2 3 4 5 6 7 8	■
SFL 04020.06	NK 40	40	20	6	40	12.000	19.100	A2200040206040	1 2 3 4 5 6 7 8	■
SFL 04020.06	NK 60	40	20	6	40	12.000	19.100	A2200040206060	1 2 3 4 5 6 7 8	■
SFL 04020.06	NK 80	40	20	6	40	12.000	19.100	A2200040206080	1 2 3 4 5 6 7 8	■
SFL 04020.06	NK 120	40	20	6	40	12.000	19.100	A2200040206120	1 2 3 4 5 6 7 8	■
SFL 04020.06	NK 150	40	20	6	40	12.000	19.100	A2200040206150	1 2 3 4 5 6 7 8	■
SFL 04020.06	NK 240	40	20	6	40	12.000	19.100	A2200040206240	1 2 3 4 5 6 7 8	■
SFL 04020.06	NK 320	40	20	6	40	12.000	19.100	A2200040206320	1 2 3 4 5 6 7 8	■
SFL 04030.06	NK 40	40	30	6	40	12.000	19.100	A2200040306040	1 2 3 4 5 6 7 8	■
SFL 04030.06	NK 60	40	30	6	40	12.000	19.100	A2200040306060	1 2 3 4 5 6 7 8	■
SFL 04030.06	NK 80	40	30	6	40	12.000	19.100	A2200040306080	1 2 3 4 5 6 7 8	■
SFL 05010.06	NK 60	50	10	6	40	9.000	15.300	A2200050106060	1 2 3 4 5 6 7 8	■
SFL 05010.06	NK 80	50	10	6	40	9.000	15.300	A2200050106080	1 2 3 4 5 6 7 8	■
SFL 05010.06	NK 120	50	10	6	40	9.000	15.300	A2200050106120	1 2 3 4 5 6 7 8	■
SFL 05010.06	NK 150	50	10	6	40	9.000	15.300	A2200050106150	1 2 3 4 5 6 7 8	■
SFL 05010.06	NK 240	50	10	6	40	9.000	15.300	A2200050106240	1 2 3 4 5 6 7 8	■
SFL 05015.06	NK 40	50	15	6	40	9.000	15.300	A2200050156040	1 2 3 4 5 6 7 8	■
SFL 05015.06	NK 60	50	15	6	40	9.000	15.300	A2200050156060	1 2 3 4 5 6 7 8	■
SFL 05015.06	NK 80	50	15	6	40	9.000	15.300	A2200050156080	1 2 3 4 5 6 7 8	■
SFL 05015.06	NK 120	50	15	6	40	9.000	15.300	A2200050156120	1 2 3 4 5 6 7 8	■
SFL 05015.06	NK 150	50	15	6	40	9.000	15.300	A2200050156150	1 2 3 4 5 6 7 8	■
SFL 05015.06	NK 240	50	15	6	40	9.000	15.300	A2200050156240	1 2 3 4 5 6 7 8	■
SFL 05015.06	NK 320	50	15	6	40	9.000	15.300	A2200050156320	1 2 3 4 5 6 7 8	■
SFL 05020.06	NK 40	50	20	6	40	9.000	15.300	A2200050206040	1 2 3 4 5 6 7 8	■

The stated maximum operating speed only applies to a maximum overhang L_0 of 20 mm. Other overhang dimensions must be calculated separately.

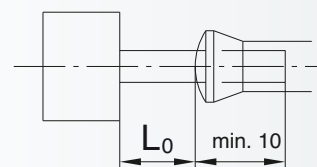



Industry

SFL, Flap wheels

Ordering example: A2200050206060

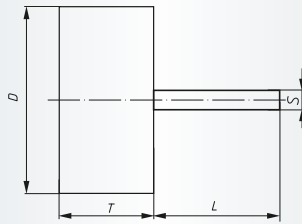
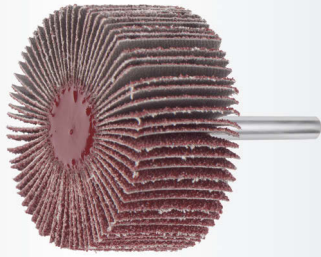

Packing unit:

10 pcs. per type

Further dimensions, qualities

and shank lengths on request

NK = reg. Aluminium Oxide

Description	Grits	D mm	T mm	S mm	L mm	n recom. (1/min)	n max. (1/min)	Product-Number	recommended for	
SFL 05020.06	NK 60	50	20	6	40	9.000	15.300	A2200050206060	① ② ③ ④ ⑤ ⑥ ⑦ ⑧	■
SFL 05020.06	NK 80	50	20	6	40	9.000	15.300	A2200050206080	① ② ③ ④ ⑤ ⑥ ⑦ ⑧	■
SFL 05020.06	NK 120	50	20	6	40	9.000	15.300	A2200050206120	① ② ③ ④ ⑤ ⑥ ⑦ ⑧	■
SFL 05020.06	NK 150	50	20	6	40	9.000	15.300	A2200050206150	① ② ③ ④ ⑤ ⑥ ⑦ ⑧	■
SFL 05020.06	NK 240	50	20	6	40	9.000	15.300	A2200050206240	① ② ③ ④ ⑤ ⑥ ⑦ ⑧	■
SFL 05020.06	NK 320	50	20	6	40	9.000	15.300	A2200050206320	① ② ③ ④ ⑤ ⑥ ⑦ ⑧	■
SFL 05030.06	NK 40	50	30	6	40	9.000	15.300	A2200050306040	① ② ③ ④ ⑤ ⑥ ⑦ ⑧	■
SFL 05030.06	NK 60	50	30	6	40	9.000	15.300	A2200050306060	① ② ③ ④ ⑤ ⑥ ⑦ ⑧	■
SFL 05030.06	NK 80	50	30	6	40	9.000	15.300	A2200050306080	① ② ③ ④ ⑤ ⑥ ⑦ ⑧	■
SFL 05030.06	NK 120	50	30	6	40	9.000	15.300	A2200050306120	① ② ③ ④ ⑤ ⑥ ⑦ ⑧	■
SFL 05030.06	NK 150	50	30	6	40	9.000	15.300	A2200050306150	① ② ③ ④ ⑤ ⑥ ⑦ ⑧	■
SFL 05030.06	NK 320	50	30	6	40	9.000	15.300	A2200050306320	① ② ③ ④ ⑤ ⑥ ⑦ ⑧	■
SFL 06010.06	NK 60	60	10	6	40	8.000	12.700	A2200060106060	① ② ③ ④ ⑤ ⑥ ⑦ ⑧	■
SFL 06010.06	NK 80	60	10	6	40	8.000	12.700	A2200060106080	① ② ③ ④ ⑤ ⑥ ⑦ ⑧	■
SFL 06015.06	NK 40	60	15	6	40	8.000	12.700	A2200060156040	① ② ③ ④ ⑤ ⑥ ⑦ ⑧	■
SFL 06015.06	NK 60	60	15	6	40	8.000	12.700	A2200060156060	① ② ③ ④ ⑤ ⑥ ⑦ ⑧	■
SFL 06015.06	NK 80	60	15	6	40	8.000	12.700	A2200060156080	① ② ③ ④ ⑤ ⑥ ⑦ ⑧	■
SFL 06015.06	NK 120	60	15	6	40	8.000	12.700	A2200060156120	① ② ③ ④ ⑤ ⑥ ⑦ ⑧	■
SFL 06015.06	NK 150	60	15	6	40	8.000	12.700	A2200060156150	① ② ③ ④ ⑤ ⑥ ⑦ ⑧	■
SFL 06015.06	NK 240	60	15	6	40	8.000	12.700	A2200060156240	① ② ③ ④ ⑤ ⑥ ⑦ ⑧	■
SFL 06015.06	NK 320	60	15	6	40	8.000	12.700	A2200060156320	① ② ③ ④ ⑤ ⑥ ⑦ ⑧	■
SFL 06020.06	NK 40	60	20	6	40	8.000	12.700	A2200060206040	① ② ③ ④ ⑤ ⑥ ⑦ ⑧	■
SFL 06020.06	NK 60	60	20	6	40	8.000	12.700	A2200060206060	① ② ③ ④ ⑤ ⑥ ⑦ ⑧	■
SFL 06020.06	NK 80	60	20	6	40	8.000	12.700	A2200060206080	① ② ③ ④ ⑤ ⑥ ⑦ ⑧	■
SFL 06020.06	NK 120	60	20	6	40	8.000	12.700	A2200060206120	① ② ③ ④ ⑤ ⑥ ⑦ ⑧	■
SFL 06020.06	NK 150	60	20	6	40	8.000	12.700	A2200060206150	① ② ③ ④ ⑤ ⑥ ⑦ ⑧	■
SFL 06020.06	NK 240	60	20	6	40	8.000	12.700	A2200060206240	① ② ③ ④ ⑤ ⑥ ⑦ ⑧	■
SFL 06020.06	NK 320	60	20	6	40	8.000	12.700	A2200060206320	① ② ③ ④ ⑤ ⑥ ⑦ ⑧	■
SFL 06030.06	NK 40	60	30	6	40	8.000	12.700	A2200060306040	① ② ③ ④ ⑤ ⑥ ⑦ ⑧	■
SFL 06030.06	NK 60	60	30	6	40	8.000	12.700	A2200060306060	① ② ③ ④ ⑤ ⑥ ⑦ ⑧	■
SFL 06030.06	NK 80	60	30	6	40	8.000	12.700	A2200060306080	① ② ③ ④ ⑤ ⑥ ⑦ ⑧	■
SFL 06030.06	NK 120	60	30	6	40	8.000	12.700	A2200060306120	① ② ③ ④ ⑤ ⑥ ⑦ ⑧	■

The stated maximum operating speed only applies to a maximum overhang L_0 of 20 mm. Other overhang dimensions must be calculated separately.

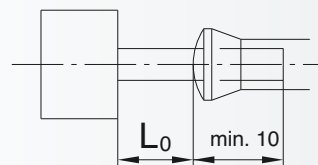



SFL, Flap wheels

Ordering example: A2200060306150

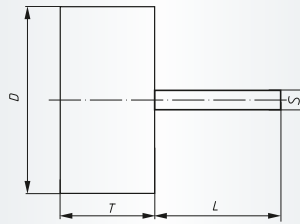
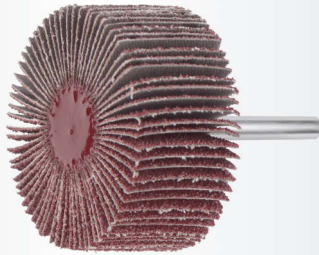

Packing unit:

10 pcs. per type

Further dimensions, qualities

and shank lengths on request

NK = reg. Aluminium Oxide

Description	Grits	D mm	T mm	S mm	L mm	n recom. (1/min)	n max. (1/min)	Product-Number	recommended for	
SFL 06030.06	NK 150	60	30	6	40	8.000	12.700	A2200060306150	① ② ③ ④ ⑤ ⑥ ⑦ ⑧	■
SFL 06030.06	NK 240	60	30	6	40	8.000	12.700	A2200060306240	① ② ③ ④ ⑤ ⑥ ⑦ ⑧	■
SFL 06030.06	NK 320	60	30	6	40	8.000	12.700	A2200060306320	① ② ③ ④ ⑤ ⑥ ⑦ ⑧	■
SFL 06040.06	NK 40	60	40	6	40	8.000	12.700	A2200060406040	① ② ③ ④ ⑤ ⑥ ⑦ ⑧	■
SFL 06040.06	NK 60	60	40	6	40	8.000	12.700	A2200060406060	① ② ③ ④ ⑤ ⑥ ⑦ ⑧	■
SFL 06040.06	NK 80	60	40	6	40	8.000	12.700	A2200060406080	① ② ③ ④ ⑤ ⑥ ⑦ ⑧	■
SFL 06040.06	NK 120	60	40	6	40	8.000	12.700	A2200060406120	① ② ③ ④ ⑤ ⑥ ⑦ ⑧	■
SFL 06040.06	NK 150	60	40	6	40	8.000	12.700	A2200060406150	① ② ③ ④ ⑤ ⑥ ⑦ ⑧	■
SFL 06040.06	NK 240	60	40	6	40	8.000	12.700	A2200060406240	① ② ③ ④ ⑤ ⑥ ⑦ ⑧	■
SFL 06040.06	NK 320	60	40	6	40	8.000	12.700	A2200060406320	① ② ③ ④ ⑤ ⑥ ⑦ ⑧	■
SFL 06050.06	NK 40	60	50	6	40	8.000	8.500	A2200060506040	① ② ③ ④ ⑤ ⑥ ⑦ ⑧	■
SFL 06050.06	NK 60	60	50	6	40	8.000	8.500	A2200060506060	① ② ③ ④ ⑤ ⑥ ⑦ ⑧	■
SFL 06050.06	NK 80	60	50	6	40	8.000	8.500	A2200060506080	① ② ③ ④ ⑤ ⑥ ⑦ ⑧	■
SFL 06050.06	NK 120	60	50	6	40	8.000	8.500	A2200060506120	① ② ③ ④ ⑤ ⑥ ⑦ ⑧	■
SFL 06050.06	NK 150	60	50	6	40	8.000	8.500	A2200060506150	① ② ③ ④ ⑤ ⑥ ⑦ ⑧	■
SFL 06050.06	NK 240	60	50	6	40	8.000	8.500	A2200060506240	① ② ③ ④ ⑤ ⑥ ⑦ ⑧	■
SFL 08015.06	NK 60	80	15	6	40	6.000	9.500	A2200080156060	① ② ③ ④ ⑤ ⑥ ⑦ ⑧	■
SFL 08015.06	NK 80	80	15	6	40	6.000	9.500	A2200080156080	① ② ③ ④ ⑤ ⑥ ⑦ ⑧	■
SFL 08015.06	NK 120	80	15	6	40	6.000	9.500	A2200080156120	① ② ③ ④ ⑤ ⑥ ⑦ ⑧	■
SFL 08015.06	NK 150	80	15	6	40	6.000	9.500	A2200080156150	① ② ③ ④ ⑤ ⑥ ⑦ ⑧	■
SFL 08015.06	NK 240	80	15	6	40	6.000	9.500	A2200080156240	① ② ③ ④ ⑤ ⑥ ⑦ ⑧	■
SFL 08015.06	NK 320	80	15	6	40	6.000	9.500	A2200080156320	① ② ③ ④ ⑤ ⑥ ⑦ ⑧	■
SFL 08020.06	NK 60	80	20	6	40	6.000	9.500	A2200080206060	① ② ③ ④ ⑤ ⑥ ⑦ ⑧	■
SFL 08020.06	NK 80	80	20	6	40	6.000	9.500	A2200080206080	① ② ③ ④ ⑤ ⑥ ⑦ ⑧	■
SFL 08020.06	NK 120	80	20	6	40	6.000	9.500	A2200080206120	① ② ③ ④ ⑤ ⑥ ⑦ ⑧	■
SFL 08020.06	NK 150	80	20	6	40	6.000	9.500	A2200080206150	① ② ③ ④ ⑤ ⑥ ⑦ ⑧	■
SFL 08030.06	NK 40	80	30	6	40	6.000	9.500	A2200080306040	① ② ③ ④ ⑤ ⑥ ⑦ ⑧	■
SFL 08030.06	NK 60	80	30	6	40	6.000	9.500	A2200080306060	① ② ③ ④ ⑤ ⑥ ⑦ ⑧	■
SFL 08030.06	NK 80	80	30	6	40	6.000	9.500	A2200080306080	① ② ③ ④ ⑤ ⑥ ⑦ ⑧	■
SFL 08030.06	NK 120	80	30	6	40	6.000	9.500	A2200080306120	① ② ③ ④ ⑤ ⑥ ⑦ ⑧	■
SFL 08030.06	NK 150	80	30	6	40	6.000	9.500	A2200080306150	① ② ③ ④ ⑤ ⑥ ⑦ ⑧	■
SFL 08030.06	NK 320	80	30	6	40	6.000	9.500	A2200080306320	① ② ③ ④ ⑤ ⑥ ⑦ ⑧	■

The stated maximum operating speed only applies to a maximum overhang L_0 of 20 mm. Other overhang dimensions must be calculated separately.

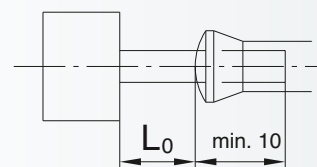



SFL, Flap wheels

Ordering example: A2200080406060

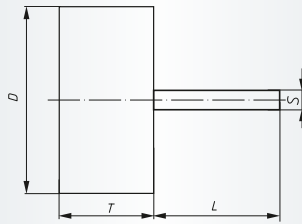
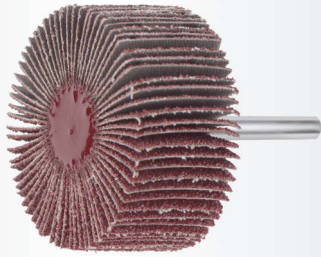

Packing unit:

10 pcs. per type

Further dimensions, qualities

and shank lengths on request

NK = reg. Aluminium Oxide

Description	Grits	D mm	T mm	S mm	L mm	n recom. (1/min)	n max. (1/min)	Product-Number	recommended for	
SFL 08040.06	NK 60	80	40	6	40	6.000	9.500	A2200080406060	① ② ③ ④ ⑤ ⑥ ⑦ ⑧	■
SFL 08040.06	NK 80	80	40	6	40	6.000	9.500	A2200080406080	① ② ③ ④ ⑤ ⑥ ⑦ ⑧	■
SFL 08040.06	NK 150	80	40	6	40	6.000	9.500	A2200080406150	① ② ③ ④ ⑤ ⑥ ⑦ ⑧	■
SFL 08050.06	NK 40	80	50	6	40	6.000	7.500	A2200080506040	① ② ③ ④ ⑤ ⑥ ⑦ ⑧	■
SFL 08050.06	NK 60	80	50	6	40	6.000	7.500	A2200080506060	① ② ③ ④ ⑤ ⑥ ⑦ ⑧	■
SFL 08050.06	NK 80	80	50	6	40	6.000	7.500	A2200080506080	① ② ③ ④ ⑤ ⑥ ⑦ ⑧	■
SFL 08050.06	NK 120	80	50	6	40	6.000	7.500	A2200080506120	① ② ③ ④ ⑤ ⑥ ⑦ ⑧	■
SFL 08050.06	NK 150	80	50	6	40	6.000	7.500	A2200080506150	① ② ③ ④ ⑤ ⑥ ⑦ ⑧	■
SFL 08050.06	NK 240	80	50	6	40	6.000	7.500	A2200080506240	① ② ③ ④ ⑤ ⑥ ⑦ ⑧	■
SFL 08050.06	NK 320	80	50	6	40	6.000	7.500	A2200080506320	① ② ③ ④ ⑤ ⑥ ⑦ ⑧	■
SFL 10040.08	NK 40	100	40	8	40	5.000	7.500	A2200100408040	① ② ③ ④ ⑤ ⑥ ⑦ ⑧	■
SFL 10040.08	NK 60	100	40	8	40	5.000	7.500	A2200100408060	① ② ③ ④ ⑤ ⑥ ⑦ ⑧	■
SFL 10050.08	NK 60	100	50	8	40	5.000	7.500	A2200100508060	① ② ③ ④ ⑤ ⑥ ⑦ ⑧	■
SFL 10050.08	NK 80	100	50	8	40	5.000	7.500	A2200100508080	① ② ③ ④ ⑤ ⑥ ⑦ ⑧	■
SFL 10050.08	NK 150	100	50	8	40	5.000	7.500	A2200100508150	① ② ③ ④ ⑤ ⑥ ⑦ ⑧	■

The stated maximum operating speed only applies to a maximum overhang L_0 of 20 mm. Other overhang dimensions must be calculated separately.

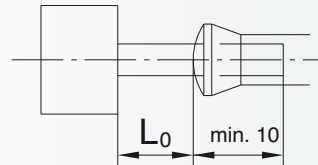



SFB, Slotted flap wheel

Ordering example: A2220040206080

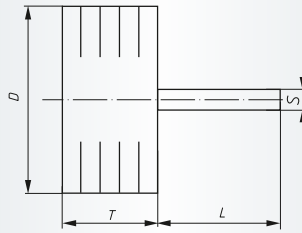
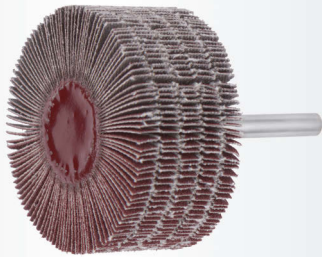

Packing unit:

10 pcs. per type

Further dimensions, qualities and shank lengths on request

NK = reg. Aluminium Oxide

Description	Grits	D mm	T mm	S mm	L mm	n recom. (1/min)	n max. (1/min)	Product-Number	recommended for	
SFB 04020.06	NK 80	40	20	6	40	12.000	19.100	A2220040206080	① ② ③ ④ ⑤ ⑥ ⑦ ⑧	■
SFB 05020.06	NK 80	50	20	6	40	9.000	15.300	A2220050206080	① ② ③ ④ ⑤ ⑥ ⑦ ⑧	■
SFB 05030.06	NK 120	50	30	6	40	9.000	15.300	A2220050306120	① ② ③ ④ ⑤ ⑥ ⑦ ⑧	■
SFB 06030.06	NK 80	60	30	6	40	8.000	12.700	A2220060306080	① ② ③ ④ ⑤ ⑥ ⑦ ⑧	■
SFB 06030.06	NK 120	60	30	6	40	8.000	12.700	A2220060306120	① ② ③ ④ ⑤ ⑥ ⑦ ⑧	■

By slotting the lamellas on the periphery, the flexibility of this type of mounted wheel is increased. The slotted flap wheel quickly profiles itself to the contour of the workpiece. For special dimensions and grit sizes minimum quantity on request.

The stated maximum operating speed only applies to a maximum overhang L_0 of 20 mm. Other overhang dimensions must be calculated separately.

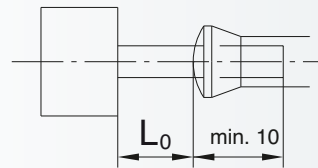



Industry

SFE, Flap wheels of abrasive cloth, regular aluminium oxide, special bond

Ordering example: A2201030103120

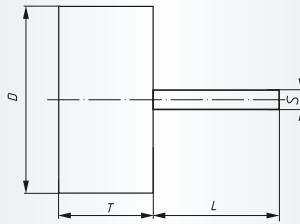

Packing unit:

10 pcs. per type

Further dimensions, qualities and shank lengths on request

NKE = reg. Aluminium Oxide with a coating of active grinding additives

Description	Grits	D mm	T mm	S mm	L mm	n recom. (1/min)	n max. (1/min)	Product-Number	recommended for	
SFE 03010.03	NKE 120	30	10	3	40	16.000	18.000	A2201030103120	① ② ③ ④ ⑤ ⑥ ⑦ ⑧	■
SFE 03010.06	NKE 60	30	10	6	40	16.000	25.400	A2201030106060	① ② ③ ④ ⑤ ⑥ ⑦ ⑧	■
SFE 03010.06	NKE 80	30	10	6	40	16.000	25.400	A2201030106080	① ② ③ ④ ⑤ ⑥ ⑦ ⑧	■
SFE 03010.06	NKE 150	30	10	6	40	16.000	25.400	A2201030106150	① ② ③ ④ ⑤ ⑥ ⑦ ⑧	■
SFE 04015.06	NKE 60	40	15	6	40	12.000	19.100	A2201040156060	① ② ③ ④ ⑤ ⑥ ⑦ ⑧	■
SFE 04015.06	NKE 80	40	15	6	40	12.000	19.100	A2201040156080	① ② ③ ④ ⑤ ⑥ ⑦ ⑧	■
SFE 04015.06	NKE 120	40	15	6	40	12.000	19.100	A2201040156120	① ② ③ ④ ⑤ ⑥ ⑦ ⑧	■
SFE 05015.06	NKE 80	50	15	6	40	9.000	15.300	A2201050156080	① ② ③ ④ ⑤ ⑥ ⑦ ⑧	■
SFE 05015.06	NKE 150	50	15	6	40	9.000	15.300	A2201050156150	① ② ③ ④ ⑤ ⑥ ⑦ ⑧	■
SFE 06020.06	NKE 80	60	20	6	40	8.000	12.700	A2201060206080	① ② ③ ④ ⑤ ⑥ ⑦ ⑧	■
SFE 06030.06	NKE 60	60	30	6	40	8.000	12.700	A2201060306060	① ② ③ ④ ⑤ ⑥ ⑦ ⑧	■
SFE 06030.06	NKE 80	60	30	6	40	8.000	12.700	A2201060306080	① ② ③ ④ ⑤ ⑥ ⑦ ⑧	■
SFE 06030.06	NKE 120	60	30	6	40	8.000	12.700	A2201060306120	① ② ③ ④ ⑤ ⑥ ⑦ ⑧	■
SFE 06030.06	NKE 150	60	30	6	40	8.000	12.700	A2201060306150	① ② ③ ④ ⑤ ⑥ ⑦ ⑧	■
SFE 06050.06	NKE 60	60	50	6	40	8.000	8.500	A2201060506060	① ② ③ ④ ⑤ ⑥ ⑦ ⑧	■
SFE 06050.06	NKE 120	60	50	6	40	8.000	8.500	A2201060506120	① ② ③ ④ ⑤ ⑥ ⑦ ⑧	■
SFE 08030.06	NKE 80	80	30	6	40	6.000	9.500	A2201080306080	① ② ③ ④ ⑤ ⑥ ⑦ ⑧	■
SFE 08050.06	NKE 80	80	50	6	40	6.000	7.500	A2201080506080	① ② ③ ④ ⑤ ⑥ ⑦ ⑧	■

The stated maximum operating speed only applies to a maximum overhang L_0 of 20 mm. Other overhang dimensions must be calculated separately.

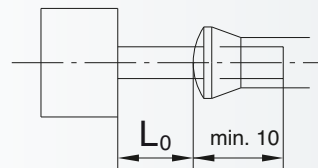

270 Mounted flap wheels of abrasive cloth



Industry

SFC, Flap wheels of abrasive cloth, silicon carbide

Ordering example: A2202030106080

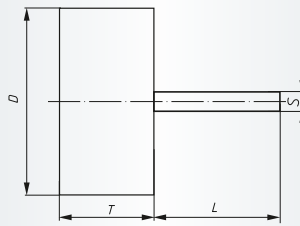
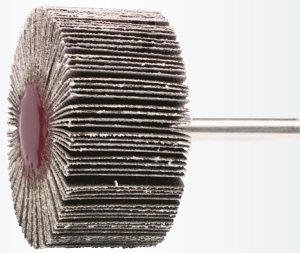

Packing unit:

10 pcs. per type

Further dimensions, qualities and shank lengths on request

SIC = silicon carbide

Description	Grits	D mm	T mm	S mm	L mm	n recom. (1/min)	n max. (1/min)	Product-Number	recommended for	
SFC 03010.06	SIC 80	30	10	6	40	16.000	25.400	A2202030106080	① ② ③ ④ ⑤ ⑥ ⑦ ⑧ ⑨	■
SFC 03010.06	SIC 150	30	10	6	40	16.000	25.400	A2202030106150	① ② ③ ④ ⑤ ⑥ ⑦ ⑧ ⑨	■
SFC 04015.06	SIC 80	40	15	6	40	12.000	19.100	A2202040156080	① ② ③ ④ ⑤ ⑥ ⑦ ⑧ ⑨	■
SFC 06020.06	SIC 80	60	20	6	40	8.000	12.700	A2202060206080	① ② ③ ④ ⑤ ⑥ ⑦ ⑧ ⑨	■
SFC 06020.06	SIC 120	60	20	6	40	8.000	12.700	A2202060206120	① ② ③ ④ ⑤ ⑥ ⑦ ⑧ ⑨	■
SFC 06030.06	SIC 120	60	30	6	40	8.000	12.700	A2202060306120	① ② ③ ④ ⑤ ⑥ ⑦ ⑧ ⑨	■

The stated maximum operating speed only applies to a maximum overhang L_0 of 20 mm. Other overhang dimensions must be calculated separately.

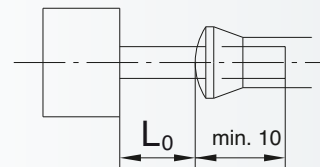



Industry

SFI, Mounted flap wheels of abrasive cloth, with internal thread

Ordering example: A2207030050120

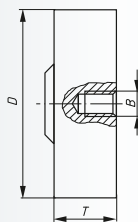
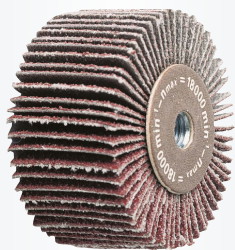

Packing unit:

10 pcs. per type

Further dimensions and qualities on request.

NK = reg. Aluminium Oxide

Description	Grits	D mm	T mm	Thread B	n recom. (1/min)	n max. (1/min)	suitable tool adaptor	Product-Number	recommended for	
SFI 03005.M4	NK 120	30	5	M4	16.000	18.000	WADI 0404	A2207030050120	① ② ③ ④ ⑤ ⑥ ⑦ ⑧	■
SFI 03010.M4	NK 120	30	10	M4	16.000	18.000	WADI 0407	A2207030100120	① ② ③ ④ ⑤ ⑥ ⑦ ⑧	■
SFI 03010.M4	NK 150	30	10	M4	16.000	18.000	WADI 0407	A2207030100150	① ② ③ ④ ⑤ ⑥ ⑦ ⑧	■
SFI 04015.M6	NK 80	40	15	M6	10.000	10.000	WADI 0609	A2207040150080	① ② ③ ④ ⑤ ⑥ ⑦ ⑧	■
SFI 04015.M6	NK 120	40	15	M6	10.000	10.000	WADI 0609	A2207040150120	① ② ③ ④ ⑤ ⑥ ⑦ ⑧	■
SFI 05020.M6	NK 80	50	20	M6	7.500	7.500	WADI 0612	A2207050200080	① ② ③ ④ ⑤ ⑥ ⑦ ⑧	■

The stated maximum permissible operating speed is only valid if the correct tool adaptor is used (see table).



Industry

Adaptor for SFI

Ordering example: A36300404

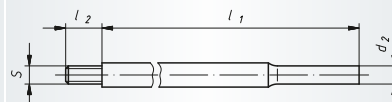

Packing unit:

1 pc. per type

Description	d ₂ mm	l ₁ mm	S mm	l ₂ mm	Product-Number																	
WADI 0404	6	80	M4	4	A36300404																■	
WADI 0407	6	80	M4	7	A36300407																	■
WADI 0609	6	100	M6	9	A36300609																	■
WADI 0612	6	100	M6	12	A36300612																	■

272 Mounted flap wheels of abrasive cloth with thread



Industry

SFA, Flap wheels of abrasive cloth, with external thread

Ordering example: A2200015055150

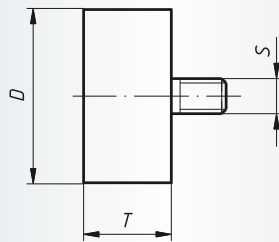
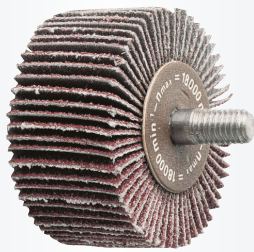

Packing unit:

10 pcs. per type

Further dimensions and qualities on request.

NK = reg. Aluminium Oxide

Description	Grits	D mm	T mm	Thread S	n recom. (1/min)	n max. (1/min)	Product-Number	recommended for	
SFA 01505.M5	NK 150	15	5	M5	16.000	18.000	A2200015055150	① ② ③ ④ ⑤ ⑥ ⑦ ⑧	■
SFA 01505.M5	NK 240	15	5	M5	16.000	18.000	A2200015055240	① ② ③ ④ ⑤ ⑥ ⑦ ⑧	■
SFA 02005.M5	NK 150	20	5	M5	16.000	18.000	A2200020055150	① ② ③ ④ ⑤ ⑥ ⑦ ⑧	■
SFA 02005.M5	NK 240	20	5	M5	16.000	18.000	A2200020055240	① ② ③ ④ ⑤ ⑥ ⑦ ⑧	■
SFA 03005.M5	NK 120	30	5	M5	16.000	18.000	A2200030055120	① ② ③ ④ ⑤ ⑥ ⑦ ⑧	■
SFA 03005.M5	NK 150	30	5	M5	16.000	18.000	A2200030055150	① ② ③ ④ ⑤ ⑥ ⑦ ⑧	■
SFA 03005.M5	NK 240	30	5	M5	16.000	18.000	A2200030055240	① ② ③ ④ ⑤ ⑥ ⑦ ⑧	■

The stated maximum permissible operating speed is only valid if the correct tool adaptor is used (see table).



Industry

Adaptor for SFA

Ordering example: A36300518

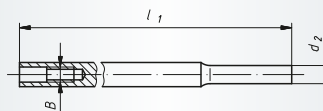

Packing unit:

1 pc. per type

Description	d2 mm	l1 mm	B mm	Product-Number		
WADA 05	6	100	M5	A36300518		■



MFS, Mini-Flap wheels of abrasive cloth

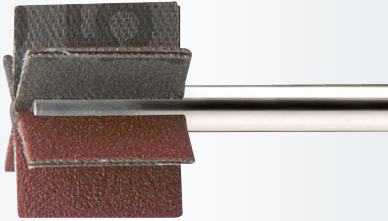

Applications:

- Deburring of drill holes
- Production and cleaning of moulds for glass-industry
- Inside processing/machining of tubes
- Processing of light alloy rims
- Processing of the borings of turbine blades
- Manifold special applications

Advantages:

- Possibility of fine-grinding and finishing work
- The arrangement of the lamellars ensure high flexibility
- Good circulation of air and though cold grinding
- Processing of small borings and inner-diameters of tubes

Mini-Flap wheels with a diameter of 10–30 mm are available with different shank lengths and qualities.

available on request



Always the right tool





Bajram Loshaj
Engineering Department

Filing ring: I take pride in having been involved in the development process for this thin-walled tool, starting out from a forged tool steel blank up to the finished toothed filing ring.

www.lukas-erzett.com

Notes

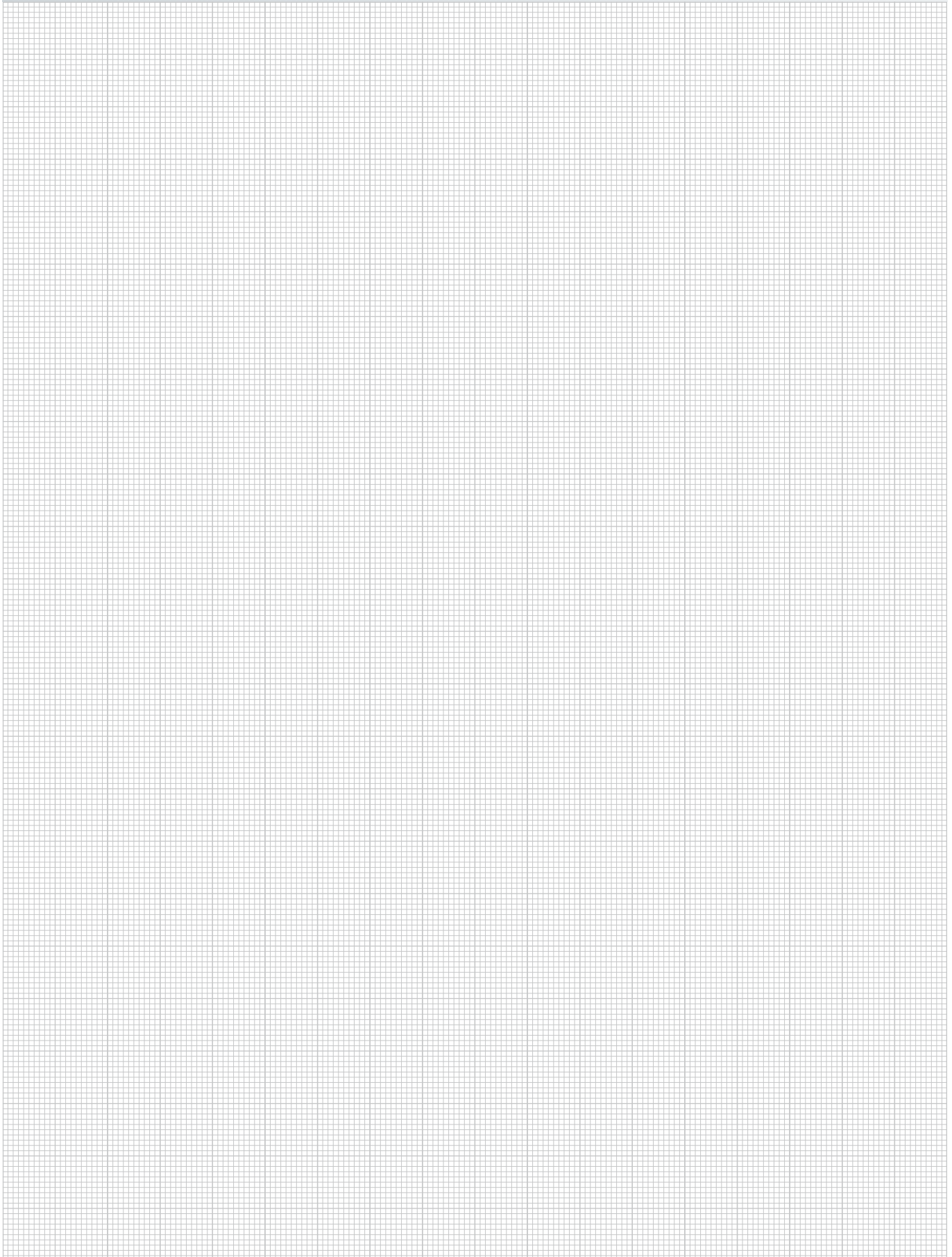
A large rectangular area filled with a fine grid pattern, intended for taking notes. The grid consists of small, uniform squares.

Flap wheel consisting of an abrasive fleece and abrasive cloth combination

228 Qualities and Applications

276 General Information

277 Mounted flap wheels abrasive fleece lamellar inserts

280 Mounted flap wheels abrasive fleece disc inserts

281 Mounted flap wheels of abrasive fleece/
abrasive cloth combination

381 Power tool

Product line marking

Product lines are labelled in the table header with the appropriate tabs. Further information on page **14** and **15**.

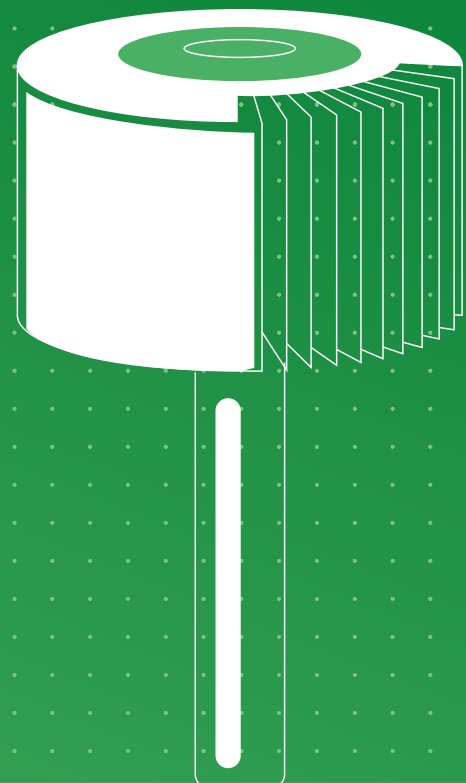
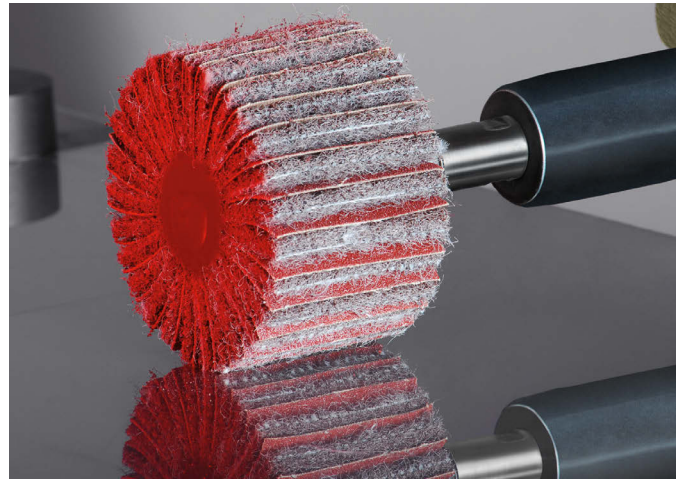

Information

SFV, Flap wheels of fleece flaps

These tools consist of individual flaps radially located around the hub of the tool. They are available in regular aluminium oxide (A), silicon carbide (C) and zirconia aluminium oxide (Z). SFV are mainly used in hand-held power tools.

Examples of application:

- matting
- conditioning
- polishing
- finishing
- fine surface finishing

SFR, Mounted fleece discs

These special tools are produced by layering individual flexible round fleece sections. They are therefore ideally suited to the machining of profiles.

SFM, Flap wheels of abrasive fleece with abrasive cloth

These tools consist of individual flaps radially located around the hub of the tool. They are available in regular aluminium oxide (A), silicon carbide (C) and zirconia aluminium oxide.

The combination of coated abrasive and abrasive fleece allows for a greater stock removal compared to the SFV product type. SFM are mainly used in hand-held power tools.

Examples of application:

- preparation work
- de-rusting
- pre-finishing
- graining
- keying

SFM, spindle mounted flap wheels with TF-material

These tools are particularly suited to stainless steel applications. The reverse side of the reinforced abrasive fleece guarantees uniform wear of the fleece and the coated abrasive flaps. Please take note of the rotational direction!

Quality	Grit sizes
A104	Aluminium oxide 100
A106	Aluminium oxide 180
A107	Aluminium oxide 280
C204	Silicon carbide 100
C206	Silicon carbide 180
C207	Silicon carbide 280
Z304	Zirconia Alum. Oxide 100
Z306	Zirconia Alum. Oxide 180
Z307	Zirconia Alum. Oxide 280



High Performance

SFV, Flap wheels of fleece flaps, zirconia aluminium oxide

Ordering example: A2203030106306

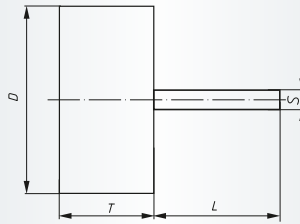

Packing unit:

10 pcs. per type

Further dimensions, qualities and shank lengths on request.

Z = Zirconia aluminium oxide

Description	Grits	D mm	T mm	S mm	L mm	n recom. (1/min)	n max. (1/min)	Product-Number	recommended for	
SFV 03010.06	Z 306	30	10	6	40	10.000	14.000	A2203030106306	1 2 3 4 5 6 7 8	■
SFV 04020.06	Z 306	40	20	6	40	7.500	14.000	A2203040206306	1 2 3 4 5 6 7 8	■
SFV 05010.06	Z 306	50	10	6	40	6.000	11.000	A2203050106306	1 2 3 4 5 6 7 8	■
SFV 06030.06	Z 306	60	30	6	40	5.000	9.000	A2203060306306	1 2 3 4 5 6 7 8	■
SFV 08050.06	Z 306	80	50	6	40	4.000	7.000	A2203080506306	1 2 3 4 5 6 7 8	■

The stated maximum operating speed only applies to a maximum overhang L_0 of 20 mm. Other overhang dimensions must be calculated separately.

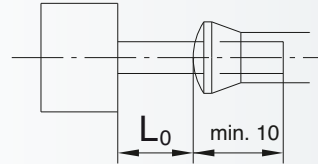

Industry

SFV, Flap wheels of fleece flaps, reg. Aluminium Oxide

Ordering example: A2203030206106

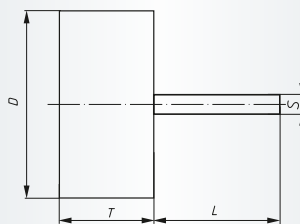
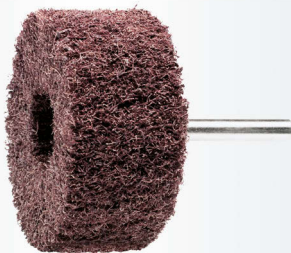

Packing unit:

10 pcs. per type

Further dimensions, qualities and shank lengths on request.

A = reg. Aluminium Oxide

Description	Grits	D mm	T mm	S mm	L mm	n recom. (1/min)	n max. (1/min)	Product-Number	recommended for	
SFV 03020.06	A 106	30	20	6	40	7.500	14.000	A2203030206106	1 2 3 4 5 6 7 8	■
SFV 03040.06	A 107	30	40	6	40	10.000	14.000	A2203030406107	1 2 3 4 5 6 7 8	■
SFV 04020.06	A 104	40	20	6	40	7.500	14.000	A2203040206104	1 2 3 4 5 6 7 8	■
SFV 04020.06	A 106	40	20	6	40	7.500	14.000	A2203040206106	1 2 3 4 5 6 7 8	■
SFV 04020.06	A 107	40	20	6	40	7.500	14.000	A2203040206107	1 2 3 4 5 6 7 8	■
SFV 04030.06	A 104	40	30	6	40	7.500	14.000	A2203040306104	1 2 3 4 5 6 7 8	■
SFV 04030.06	A 106	40	30	6	40	7.500	14.000	A2203040306106	1 2 3 4 5 6 7 8	■
SFV 04030.06	A 107	40	30	6	40	7.500	14.000	A2203040306107	1 2 3 4 5 6 7 8	■

The stated maximum operating speed only applies to a maximum overhang L_0 of 20 mm. Other overhang dimensions must be calculated separately.

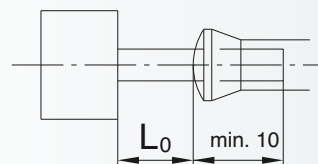



SFV, Flap wheels of fleece flaps, reg. Aluminium Oxide

Ordering example: A2203050106106

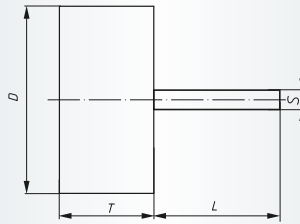

Packing unit:

10 pcs. per type

Further dimensions, qualities and shank lengths on request.

A = reg. Aluminium Oxide

Description	Grits	D mm	T mm	S mm	L mm	n recom. (1/min)	n max. (1/min)	Product-Number	recommended for	
SFV 05010.06	A 106	50	10	6	40	6.000	11.000	A2203050106106	1 2 3 4 5 6 7 8	■
SFV 05020.06	A 104	50	20	6	40	6.000	11.000	A2203050206104	1 2 3 4 5 6 7 8	■
SFV 05020.06	A 106	50	20	6	40	6.000	11.000	A2203050206106	1 2 3 4 5 6 7 8	■
SFV 05030.06	A 104	50	30	6	40	6.000	11.000	A2203050306104	1 2 3 4 5 6 7 8	■
SFV 05030.06	A 106	50	30	6	40	6.000	11.000	A2203050306106	1 2 3 4 5 6 7 8	■
SFV 05030.06	A 107	50	30	6	40	6.000	11.000	A2203050306107	1 2 3 4 5 6 7 8	■
SFV 05040.06	A 104	50	40	6	40	6.000	11.000	A2203050406104	1 2 3 4 5 6 7 8	■
SFV 05040.06	A 106	50	40	6	40	6.000	11.000	A2203050406106	1 2 3 4 5 6 7 8	■
SFV 05040.06	A 107	50	40	6	40	6.000	11.000	A2203050406107	1 2 3 4 5 6 7 8	■
SFV 06030.06	A 104	60	30	6	40	5.000	9.000	A2203060306104	1 2 3 4 5 6 7 8	■
SFV 06030.06	A 106	60	30	6	40	5.000	9.000	A2203060306106	1 2 3 4 5 6 7 8	■
SFV 06030.06	A 107	60	30	6	40	5.000	9.000	A2203060306107	1 2 3 4 5 6 7 8	■
SFV 06040.06	A 104	60	40	6	40	5.000	9.000	A2203060406104	1 2 3 4 5 6 7 8	■
SFV 06040.06	A 106	60	40	6	40	5.000	9.000	A2203060406106	1 2 3 4 5 6 7 8	■
SFV 06040.06	A 107	60	40	6	40	5.000	9.000	A2203060406107	1 2 3 4 5 6 7 8	■
SFV 06050.06	A 104	60	50	6	40	5.000	9.000	A2203060506104	1 2 3 4 5 6 7 8	■
SFV 06050.06	A 106	60	50	6	40	5.000	9.000	A2203060506106	1 2 3 4 5 6 7 8	■
SFV 06050.06	A 107	60	50	6	40	5.000	9.000	A2203060506107	1 2 3 4 5 6 7 8	■
SFV 08040.06	A 104	80	40	6	40	4.000	7.000	A2203080406104	1 2 3 4 5 6 7 8	■
SFV 08040.06	A 106	80	40	6	40	4.000	7.000	A2203080406106	1 2 3 4 5 6 7 8	■
SFV 08050.06	A 104	80	50	6	40	4.000	7.000	A2203080506104	1 2 3 4 5 6 7 8	■
SFV 08050.06	A 106	80	50	6	40	4.000	7.000	A2203080506106	1 2 3 4 5 6 7 8	■
SFV 08050.06	A 107	80	50	6	40	4.000	7.000	A2203080506107	1 2 3 4 5 6 7 8	■

The stated maximum operating speed only applies to a maximum overhang L_0 of 20 mm. Other overhang dimensions must be calculated separately.

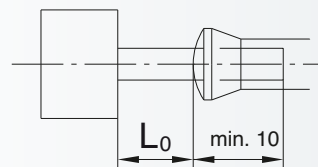



SFV, Flap wheels of fleece flaps, Silicon carbide

Ordering example: A2203020153207

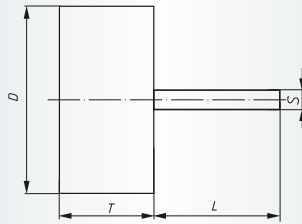
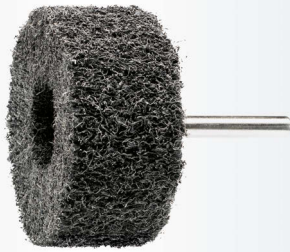

Packing unit:

10 pcs. per type

Further dimensions, qualities and shank lengths on request.

C = Silicon carbide

Description	Grits	D mm	T mm	S mm	L mm	n recom. (1/min)	n max. (1/min)	Product-Number	recommended for	
SFV 02015.03	C 207	20	15	3	40	10.000	14.000	A2203020153207	① ② ③ ④ ⑤ ⑥ ⑦ ⑧ ⑨	■
SFV 04020.06	C 206	40	20	6	40	7.500	14.000	A2203040206206	① ② ③ ④ ⑤ ⑥ ⑦ ⑧ ⑨	■
SFV 04020.06	C 207	40	20	6	40	7.500	14.000	A2203040206207	① ② ③ ④ ⑤ ⑥ ⑦ ⑧ ⑨	■
SFV 04030.06	C 207	40	30	6	40	7.500	14.000	A2203040306207	① ② ③ ④ ⑤ ⑥ ⑦ ⑧ ⑨	■
SFV 05020.06	C 204	50	20	6	40	6.000	11.000	A2203050206204	① ② ③ ④ ⑤ ⑥ ⑦ ⑧ ⑨	■
SFV 05020.06	C 206	50	20	6	40	6.000	11.000	A2203050206206	① ② ③ ④ ⑤ ⑥ ⑦ ⑧ ⑨	■
SFV 05020.06	C 207	50	20	6	40	6.000	11.000	A2203050206207	① ② ③ ④ ⑤ ⑥ ⑦ ⑧ ⑨	■
SFV 05030.06	C 207	50	30	6	40	6.000	11.000	A2203050306207	① ② ③ ④ ⑤ ⑥ ⑦ ⑧ ⑨	■
SFV 05040.06	C 207	50	40	6	40	6.000	11.000	A2203050406207	① ② ③ ④ ⑤ ⑥ ⑦ ⑧ ⑨	■
SFV 06030.06	C 204	60	30	6	40	5.000	9.000	A2203060306204	① ② ③ ④ ⑤ ⑥ ⑦ ⑧ ⑨	■
SFV 06030.06	C 206	60	30	6	40	5.000	9.000	A2203060306206	① ② ③ ④ ⑤ ⑥ ⑦ ⑧ ⑨	■
SFV 06030.06	C 207	60	30	6	40	5.000	9.000	A2203060306207	① ② ③ ④ ⑤ ⑥ ⑦ ⑧ ⑨	■
SFV 06040.06	C 204	60	40	6	40	5.000	9.000	A2203060406204	① ② ③ ④ ⑤ ⑥ ⑦ ⑧ ⑨	■
SFV 06040.06	C 207	60	40	6	40	5.000	9.000	A2203060406207	① ② ③ ④ ⑤ ⑥ ⑦ ⑧ ⑨	■
SFV 06050.06	C 207	60	50	6	40	5.000	9.000	A2203060506207	① ② ③ ④ ⑤ ⑥ ⑦ ⑧ ⑨	■
SFV 08040.06	C 204	80	40	6	40	4.000	7.000	A2203080406204	① ② ③ ④ ⑤ ⑥ ⑦ ⑧ ⑨	■
SFV 08040.06	C 206	80	40	6	40	4.000	7.000	A2203080406206	① ② ③ ④ ⑤ ⑥ ⑦ ⑧ ⑨	■
SFV 08040.06	C 207	80	40	6	40	4.000	7.000	A2203080406207	① ② ③ ④ ⑤ ⑥ ⑦ ⑧ ⑨	■
SFV 08050.06	C 204	80	50	6	40	4.000	7.000	A2203080506204	① ② ③ ④ ⑤ ⑥ ⑦ ⑧ ⑨	■
SFV 08050.06	C 206	80	50	6	40	4.000	7.000	A2203080506206	① ② ③ ④ ⑤ ⑥ ⑦ ⑧ ⑨	■
SFV 08050.06	C 207	80	50	6	40	4.000	7.000	A2203080506207	① ② ③ ④ ⑤ ⑥ ⑦ ⑧ ⑨	■

The stated maximum operating speed only applies to a maximum overhang L_0 of 20 mm. Other overhang dimensions must be calculated separately.

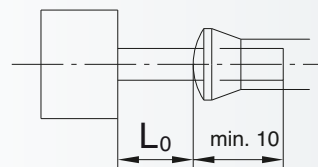

280 Mounted flap wheels of abrasive fleece



Industry

SFR, Mounted fleece discs

Ordering example: A2223060506104

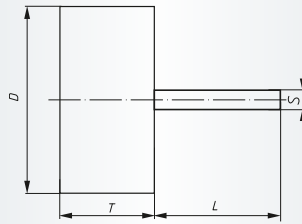

Packing unit:

10 pcs. per type

Further dimensions, qualities and shank lengths on request.

A = reg. Aluminium Oxide

Description	Grits	D mm	T mm	S mm	L mm	n recom. (1/min)	n max. (1/min)	Product-Number	recommended for	
SFR 06050.06	A 104	60	50	6	40	5.000	9.000	A2223060506104	1 2 3 4 5 6 7 8	■
SFR 06050.06	A 106	60	50	6	40	5.000	9.000	A2223060506106	1 2 3 4 5 6 7 8	■
SFR 06050.06	A 107	60	50	6	40	5.000	9.000	A2223060506107	1 2 3 4 5 6 7 8	■
SFR 08050.06	A 104	80	50	6	40	4.000	7.000	A2223080506104	1 2 3 4 5 6 7 8	■
SFR 08050.06	A 106	80	50	6	40	4.000	7.000	A2223080506106	1 2 3 4 5 6 7 8	■
SFR 08050.06	A 107	80	50	6	40	4.000	7.000	A2223080506107	1 2 3 4 5 6 7 8	■

The stated maximum operating speed only applies to a maximum overhang L_0 of 20 mm. Other overhang dimensions must be calculated separately.

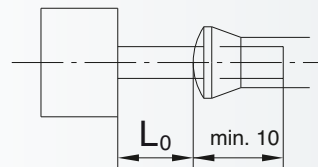



High Performance

SFM, Flap wheels of abrasive fleece TF with abrasive cloth

Ordering example: A2204040206120

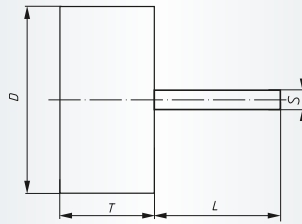
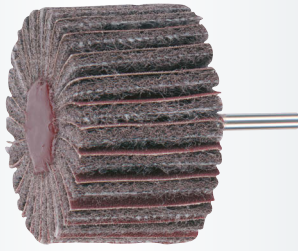

Packing unit:
10 pcs. per type
TF = Special quality for INOX

Description	Grits	D mm	T mm	S mm	L mm	n recom. (1/min)	n max. (1/min)	Product-Number	recommended for
SFM 04020.06	TF 120/80	40	20	6	40	7.500	14.000	A2204040206120	1 2 3 4 5 6 7 8
SFM 06030.06	TF 120/80	60	30	6	40	5.000	9.000	A2204060306120	1 2 3 4 5 6 7 8
SFM 08050.06	TF 120/80	80	50	6	40	4.000	7.000	A2204080506120	1 2 3 4 5 6 7 8

Ideal for surface finishing of metalsheet components such as stainless steel sinks and containers.

The stated maximum operating speed only applies to a maximum overhang L_0 of 20 mm. Other overhang dimensions must be calculated separately.

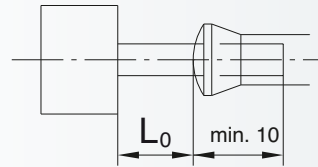

Industry

SFM, Flap wheels of abrasive fleece with abrasive cloth, reg. Aluminium Oxide

Ordering example: A2204030306104

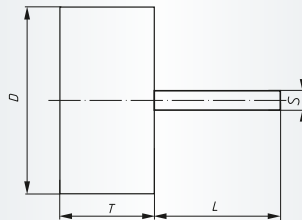
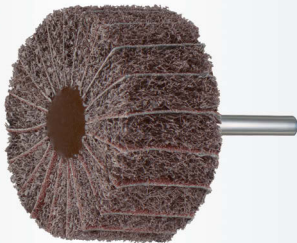

Packing unit:
10 pcs. per type
Further dimensions, qualities and shank lengths on request.
A = reg. Aluminium Oxide

Description	Grits	D mm	T mm	S mm	L mm	n recom. (1/min)	n max. (1/min)	Product-Number	recommended for
SFM 03030.06	A 104/80	30	30	6	40	10.000	14.000	A2204030306104	1 2 3 4 5 6 7 8
SFM 04020.06	A 104/80	40	20	6	40	7.500	14.000	A2204040206104	1 2 3 4 5 6 7 8
SFM 04020.06	A 106/150	40	20	6	40	7.500	14.000	A2204040206106	1 2 3 4 5 6 7 8
SFM 04020.06	A 107/240	40	20	6	40	7.500	14.000	A2204040206107	1 2 3 4 5 6 7 8
SFM 04030.06	A 104/80	40	30	6	40	7.500	14.000	A2204040306104	1 2 3 4 5 6 7 8
SFM 04030.06	A 106/150	40	30	6	40	7.500	14.000	A2204040306106	1 2 3 4 5 6 7 8
SFM 04030.06	A 107/240	40	30	6	40	7.500	14.000	A2204040306107	1 2 3 4 5 6 7 8
SFM 05020.06	A 104/80	50	20	6	40	6.000	11.000	A2204050206104	1 2 3 4 5 6 7 8
SFM 05020.06	A 106/150	50	20	6	40	6.000	11.000	A2204050206106	1 2 3 4 5 6 7 8

The stated maximum operating speed only applies to a maximum overhang L_0 of 20 mm. Other overhang dimensions must be calculated separately.

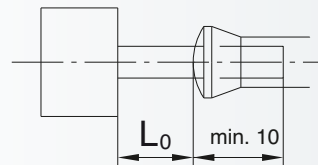



SFM, Flap wheels of abrasive fleece with abrasive cloth, reg. Aluminium Oxide

Ordering example: A2204050306106

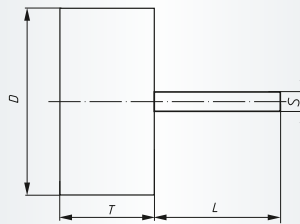
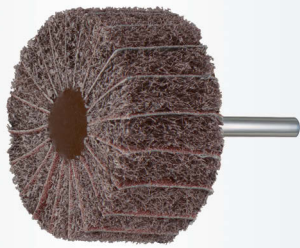

Packing unit:

10 pcs. per type

Further dimensions, qualities and shank lengths on request.

A = reg. Aluminium Oxide

Description	Grits	D mm	T mm	S mm	L mm	n recom. (1/min)	n max. (1/min)	Product-Number	recommended for	
SFM 05030.06	A 106/150	50	30	6	40	6.000	11.000	A2204050306106	1 2 3 4 5 6 7 8	■
SFM 05030.06	A 107/240	50	30	6	40	6.000	11.000	A2204050306107	1 2 3 4 5 6 7 8	■
SFM 05040.06	A 104/80	50	40	6	40	6.000	11.000	A2204050406104	1 2 3 4 5 6 7 8	■
SFM 05040.06	A 106/150	50	40	6	40	6.000	11.000	A2204050406106	1 2 3 4 5 6 7 8	■
SFM 06030.06	A 104/80	60	30	6	40	5.000	9.000	A2204060306104	1 2 3 4 5 6 7 8	■
SFM 06030.06	A 106/150	60	30	6	40	5.000	9.000	A2204060306106	1 2 3 4 5 6 7 8	■
SFM 06030.06	A 107/240	60	30	6	40	5.000	9.000	A2204060306107	1 2 3 4 5 6 7 8	■
SFM 06040.06	A 104/80	60	40	6	40	5.000	9.000	A2204060406104	1 2 3 4 5 6 7 8	■
SFM 06040.06	A 106/150	60	40	6	40	5.000	9.000	A2204060406106	1 2 3 4 5 6 7 8	■
SFM 06040.06	A 107/240	60	40	6	40	5.000	9.000	A2204060406107	1 2 3 4 5 6 7 8	■
SFM 06050.06	A 104/80	60	50	6	40	5.000	9.000	A2204060506104	1 2 3 4 5 6 7 8	■
SFM 06050.06	A 106/150	60	50	6	40	5.000	9.000	A2204060506106	1 2 3 4 5 6 7 8	■
SFM 08040.06	A 104/80	80	40	6	40	4.000	7.000	A2204080406104	1 2 3 4 5 6 7 8	■
SFM 08040.06	A 106/150	80	40	6	40	4.000	7.000	A2204080406106	1 2 3 4 5 6 7 8	■
SFM 08040.06	A 107/240	80	40	6	40	4.000	7.000	A2204080406107	1 2 3 4 5 6 7 8	■
SFM 08050.06	A 104/80	80	50	6	40	4.000	7.000	A2204080506104	1 2 3 4 5 6 7 8	■
SFM 08050.06	A 106/150	80	50	6	40	4.000	7.000	A2204080506106	1 2 3 4 5 6 7 8	■
SFM 08050.06	A 107/240	80	50	6	40	4.000	7.000	A2204080506107	1 2 3 4 5 6 7 8	■

The stated maximum operating speed only applies to a maximum overhang L_0 of 20 mm. Other overhang dimensions must be calculated separately.

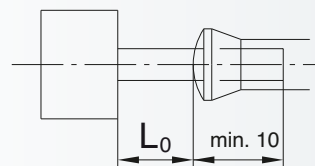



Industry

SFM, Flap wheels of abrasive fleece with abrasive cloth, Silicon carbide

Ordering example: A2204040206204

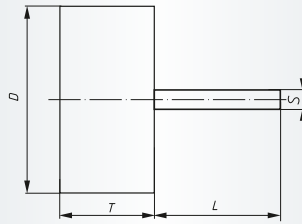

Packing unit:

10 pcs. per type

Further dimensions, qualities and shank lengths on request.

C = Silicon carbide

Description	Grits	D mm	T mm	S mm	L mm	n recom. (1/min)	n max. (1/min)	Product-Number	recommended for	
SFM 04020.06	C 204/80	40	20	6	40	7.500	14.000	A2204040206204	① ② ③ ④ ⑤ ⑥ ⑦ ⑧ ⑨	■
SFM 04020.06	C 206/150	40	20	6	40	7.500	14.000	A2204040206206	① ② ③ ④ ⑤ ⑥ ⑦ ⑧ ⑨	■
SFM 04030.06	C 204/80	40	30	6	40	7.500	14.000	A2204040306204	① ② ③ ④ ⑤ ⑥ ⑦ ⑧ ⑨	■
SFM 04030.06	C 206/150	40	30	6	40	7.500	14.000	A2204040306206	① ② ③ ④ ⑤ ⑥ ⑦ ⑧ ⑨	■
SFM 04030.06	C 207/240	40	30	6	40	7.500	14.000	A2204040306207	① ② ③ ④ ⑤ ⑥ ⑦ ⑧ ⑨	■
SFM 05020.06	C 204/80	50	20	6	40	6.000	11.000	A2204050206204	① ② ③ ④ ⑤ ⑥ ⑦ ⑧ ⑨	■
SFM 05020.06	C 206/150	50	20	6	40	6.000	11.000	A2204050206206	① ② ③ ④ ⑤ ⑥ ⑦ ⑧ ⑨	■
SFM 06030.06	C 204/80	60	30	6	40	5.000	9.000	A2204060306204	① ② ③ ④ ⑤ ⑥ ⑦ ⑧ ⑨	■
SFM 06030.06	C 206/150	60	30	6	40	5.000	9.000	A2204060306206	① ② ③ ④ ⑤ ⑥ ⑦ ⑧ ⑨	■
SFM 06030.06	C 207/240	60	30	6	40	5.000	9.000	A2204060306207	① ② ③ ④ ⑤ ⑥ ⑦ ⑧ ⑨	■
SFM 06040.06	C 204/80	60	40	6	40	5.000	9.000	A2204060406204	① ② ③ ④ ⑤ ⑥ ⑦ ⑧ ⑨	■
SFM 08050.06	C 204/80	80	50	6	40	4.000	7.000	A2204080506204	① ② ③ ④ ⑤ ⑥ ⑦ ⑧ ⑨	■
SFM 08050.06	C 206/150	80	50	6	40	4.000	7.000	A2204080506206	① ② ③ ④ ⑤ ⑥ ⑦ ⑧ ⑨	■

The stated maximum operating speed only applies to a maximum overhang L_0 of 20 mm. Other overhang dimensions must be calculated separately.

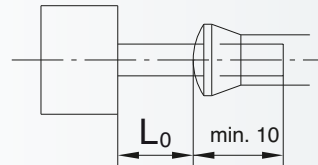

Always the right tool

For Heavy-Duty Application!



Flap wheels

228	Qualities and Applications
286	General Information
287	Flap wheels of abrasive cloth
288	Flap wheels of abrasive cloth for angle grinder
291	Flap wheels of abrasive fleece/ abrasive cloth combination
293	Fleece mops



Product line marking

Product lines are labelled in the table header with the appropriate tabs. Further information on page **14** and **15**.

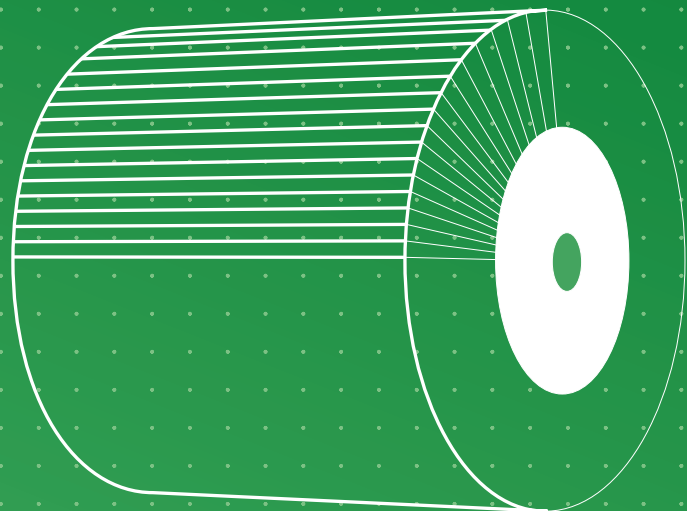

Information

LSL, Flap Wheels of abrasive cloth (tailor-made solution)

These wheels with various bore dimensions can be used on both hand-held and floor-stand type machines. The type LSL consists of individual flaps imbedded radially into a very substantial resin-based core.

Please take note of the rotational direction!

Examples of application:

- preparation work
- deburring
- de-rusting
- prefinishing
- graining
- keying

LSL, Flap Wheels of abrasive cloth for angle grinder

Advantages:

- Fits onto standard angle grinders
- Replaces the use of shaft mounted flap wheels (where no straight grinder is available)
- No flange needed
- Ideal for welding seams on Stainless Steel (tanks)

Examples of application:

- de-rusting, removal of surface coatings and oxidized layers
- cleaning of welding seams
- grinding in the tank industry and construction of railings
- grinding in the assembling industry

Application info:

Only to be used on the periphery of the wheel

LSV, Grinding wheels of abrasive fleece (tailor-made solution)

These wheels with various bore dimensions can be used on both hand-held and floor-stand type machines. The LSV consists of abrasive impregnated fleece flaps. A special type of fleece gives flexibility to the tools which easily conforms to the individual workpiece profile.

Examples of application:

- matting
- conditioning
- polishing
- finishing
- final surface finishing

LSM, Flap wheels of abrasive fleece with abrasive cloth (tailor-made solution)

These wheels with various bore dimensions can be used on both hand-held and floor-stand type machines.

Due to the combination of coated abrasive and abrasive fleece greater stock removal is achieved compared to the product type LSV. Please take note of the rotational direction!

Examples of application:

- preparation work
- de-rusting
- pre-finishing
- graining
- keying



LSL, Flap Wheels of abrasive cloth, tailor-made solution

Ordering example: LSL 125025 NK 60 Bore 13

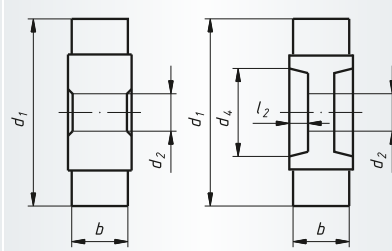

Packing unit:

Minimum ordering quantity 25 pcs. per type

$v_{rec.}$: 30 m/s off-hand application

$v_{max.}$: 50 m/s for stationary machines

* for stationary machines

Other dimensions can be supplied on request – from 80 mm to max. 400 mm.

NK = reg. Aluminium Oxide

Description	Grits	d ₁ mm	b mm	Bore d ₂ mm	recess on both sides d ₄ mm	recess on both sides l ₂ mm	n recom. (1/min)	n max. * (1/min)	recommended for	
LSL 125025	NK 60	125	25	13-16-20	---	---	4.500	7.600	① ② ③ ④ ⑤ ⑥ ⑦ ⑧	■
LSL 125025	NK 80	125	25	13-16-20	---	---	4.500	7.600	① ② ③ ④ ⑤ ⑥ ⑦ ⑧	■
LSL 125025	NK 120	125	25	13-16-20	---	---	4.500	7.600	① ② ③ ④ ⑤ ⑥ ⑦ ⑧	■
LSL 125025	NK 150	125	25	13-16-20	---	---	4.500	7.600	① ② ③ ④ ⑤ ⑥ ⑦ ⑧	■
LSL 125025	NK 240	125	25	13-16-20	---	---	4.500	7.600	① ② ③ ④ ⑤ ⑥ ⑦ ⑧	■
LSL 150050	NK 60	150	50	13-16-20	47	18	3.800	6.300	① ② ③ ④ ⑤ ⑥ ⑦ ⑧	■
LSL 150050	NK 80	150	50	13-16-20	47	18	3.800	6.300	① ② ③ ④ ⑤ ⑥ ⑦ ⑧	■
LSL 150050	NK 120	150	50	13-16-20	47	18	3.800	6.300	① ② ③ ④ ⑤ ⑥ ⑦ ⑧	■
LSL 150050	NK 150	150	50	13-16-20	47	18	3.800	6.300	① ② ③ ④ ⑤ ⑥ ⑦ ⑧	■
LSL 150050	NK 240	150	50	13-16-20	47	18	3.800	6.300	① ② ③ ④ ⑤ ⑥ ⑦ ⑧	■
LSL 165050	NK 60	165	50	13-16-20	47	18	3.400	5.700	① ② ③ ④ ⑤ ⑥ ⑦ ⑧	■
LSL 165050	NK 80	165	50	13-16-20	47	18	3.400	5.700	① ② ③ ④ ⑤ ⑥ ⑦ ⑧	■
LSL 165050	NK 120	165	50	13-16-20	47	18	3.400	5.700	① ② ③ ④ ⑤ ⑥ ⑦ ⑧	■
LSL 165050	NK 150	165	50	13-16-20	47	18	3.400	5.700	① ② ③ ④ ⑤ ⑥ ⑦ ⑧	■
LSL 165050	NK 240	165	50	13-16-20	47	18	3.400	5.700	① ② ③ ④ ⑤ ⑥ ⑦ ⑧	■
LSL 200025	NK 60	200	25	20-25-32	71	10	2.800	4.700	① ② ③ ④ ⑤ ⑥ ⑦ ⑧	■
LSL 200025	NK 80	200	25	20-25-32	71	10	2.800	4.700	① ② ③ ④ ⑤ ⑥ ⑦ ⑧	■
LSL 200025	NK 120	200	25	20-25-32	71	10	2.800	4.700	① ② ③ ④ ⑤ ⑥ ⑦ ⑧	■
LSL 200025	NK 150	200	25	20-25-32	71	10	2.800	4.700	① ② ③ ④ ⑤ ⑥ ⑦ ⑧	■
LSL 200025	NK 240	200	25	20-25-32	71	10	2.800	4.700	① ② ③ ④ ⑤ ⑥ ⑦ ⑧	■
LSL 200050	NK 60	200	50	20-25-32	71	18	2.800	4.700	① ② ③ ④ ⑤ ⑥ ⑦ ⑧	■
LSL 200050	NK 80	200	50	20-25-32	71	18	2.800	4.700	① ② ③ ④ ⑤ ⑥ ⑦ ⑧	■
LSL 200050	NK 120	200	50	20-25-32	71	18	2.800	4.700	① ② ③ ④ ⑤ ⑥ ⑦ ⑧	■
LSL 200050	NK 150	200	50	20-25-32	71	18	2.800	4.700	① ② ③ ④ ⑤ ⑥ ⑦ ⑧	■
LSL 200050	NK 240	200	50	20-25-32	71	18	2.800	4.700	① ② ③ ④ ⑤ ⑥ ⑦ ⑧	■



LSL, flap wheels from abrasive cloth with screw thread for angle grinders

Ordering example: A2280125200040

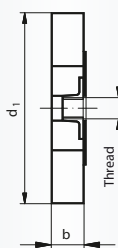

Packing unit:

5 pcs. per type

v_{max} : 80 m/s

NK = reg. Aluminium Oxide

Description	Grits	d ₁ mm	b mm	Thread	n recom. (1/min)	n max. (1/min)	Product-Number	recommended for	
LSL 125020	NK 40	125	20	M14	9.600	12.200	A2280125200040	① ② ③ ④ ⑤ ⑥ ⑦ ⑧	■
LSL 125020	NK 40	125	20	5/8"	9.600	12.200	A2280125200040001	① ② ③ ④ ⑤ ⑥ ⑦ ⑧	■
LSL 125020	NK 60	125	20	M14	9.600	12.200	A2280125200060	① ② ③ ④ ⑤ ⑥ ⑦ ⑧	■
LSL 125020	NK 60	125	20	5/8"	9.600	12.200	A2280125200060001	① ② ③ ④ ⑤ ⑥ ⑦ ⑧	■
LSL 125020	NK 80	125	20	M14	9.600	12.200	A2280125200080	① ② ③ ④ ⑤ ⑥ ⑦ ⑧	■
LSL 125020	NK 80	125	20	5/8"	9.600	12.200	A2280125200080001	① ② ③ ④ ⑤ ⑥ ⑦ ⑧	■
LSL 125020	NK 120	125	20	M14	9.600	12.200	A2280125200120	① ② ③ ④ ⑤ ⑥ ⑦ ⑧	■
LSL 125020	NK 120	125	20	5/8"	9.600	12.200	A2280125200120001	① ② ③ ④ ⑤ ⑥ ⑦ ⑧	■

Advantages:

- Fits onto standard angle grinders
- Replaces the use of shaft mounted flap wheels (where no straight grinder is available)
- No flange needed
- Ideal for welding seams on Stainless Steel (tanks)

Application examples:

- De-rusting, removal of surface coatings and oxidise layers
- Cleaning of welding seams
- Grinding in the tank industry
- Grinding in the assembling industry

Application info:

Only to be used on the periphery of the wheel



LSV, Grinding wheels of abrasive fleece, tailor-made solution

Ordering example: LSV 100050 A 104 W Bore 13

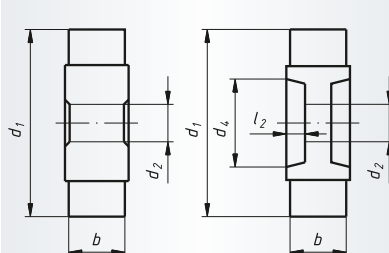

Packing unit:

Minimum ordering quantity 25 pcs. per type

v_{max} : 35 m/s

Other dimensions, bores or qualities, e.g. "very hard" or "Poly Urethane-foamed" are available on request. Possible diameters 80 mm to max. 400 mm.

A = reg. Aluminium Oxide

C = Silicon carbide

Description	Grits	Quality	d ₁ mm	b mm	Bore d ₂ mm	recess on both sides d ₄ mm	recess on both sides l ₂ mm	n recom. (1/min)	n max. (1/min)	recommended for	
LSV 100050	A 104 W	soft	100	50	13-16-20	---	---	3.000	6.000	① ② ③ ④ ⑤ ⑥ ⑦ ⑧	■
LSV 100050	A 106 W	soft	100	50	13-16-20	---	---	3.000	6.000	① ② ③ ④ ⑤ ⑥ ⑦ ⑧	■
LSV 100050	A 107 W	soft	100	50	13-16-20	---	---	3.000	6.000	① ② ③ ④ ⑤ ⑥ ⑦ ⑧	■
LSV 100050	C 204 W	soft	100	50	13-16-20	---	---	3.000	6.000	① ② ③ ④ ⑤ ⑥ ⑦ ⑧	■
LSV 100050	C 206 W	soft	100	50	13-16-20	---	---	3.000	6.000	① ② ③ ④ ⑤ ⑥ ⑦ ⑧	■
LSV 100050	C 207 W	soft	100	50	13-16-20	---	---	3.000	6.000	① ② ③ ④ ⑤ ⑥ ⑦ ⑧	■



Industry

LSV, Grinding wheels of abrasive fleece, tailor-made solution

Ordering example: LSV 100050 A 104 M Bore 13

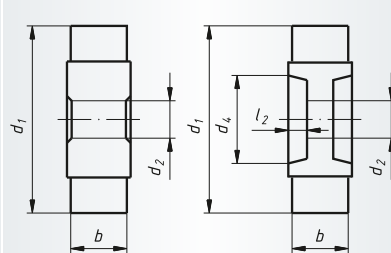

Packing unit:

Minimum ordering quantity 25 pcs. per type
 $v_{max.}$: 35 m/s

Other dimensions, bores or qualities, e.g. "very hard" or "Poly Urethane-foamed" are available on request. Possible diameters 80 mm to max. 400 mm.

A = reg. Aluminium Oxide
 C = Silicon carbide

Description	Grits	Quality	d ₁ mm	b mm	Bore d ₂ mm	recess on both sides d ₄ mm	recess on both sides l ₂ mm	n recom. (1/min)	n max. (1/min)	recommended for	
LSV 100050	A 104 M	medium	100	50	13-16-20	---	---	3.000	6.000	1 2 3 4 5 6 7 8	■
LSV 100050	A 106 M	medium	100	50	13-16-20	---	---	3.000	6.000	1 2 3 4 5 6 7 8	■
LSV 100050	A 107 M	medium	100	50	13-16-20	---	---	3.000	6.000	1 2 3 4 5 6 7 8	■
LSV 100050	C 204 M	medium	100	50	13-16-20	---	---	3.000	6.000	1 2 3 4 5 6 7 8	■
LSV 100050	C 206 M	medium	100	50	13-16-20	---	---	3.000	6.000	1 2 3 4 5 6 7 8	■
LSV 100050	C 207 M	medium	100	50	13-16-20	---	---	3.000	6.000	1 2 3 4 5 6 7 8	■
LSV 100050	A 104 H	hard	100	50	13-16-20	---	---	3.000	6.000	1 2 3 4 5 6 7 8	■
LSV 100050	A 106 H	hard	100	50	13-16-20	---	---	3.000	6.000	1 2 3 4 5 6 7 8	■
LSV 100050	A 107 H	hard	100	50	13-16-20	---	---	3.000	6.000	1 2 3 4 5 6 7 8	■
LSV 100050	C 204 H	hard	100	50	13-16-20	---	---	3.000	6.000	1 2 3 4 5 6 7 8	■
LSV 100050	C 206 H	hard	100	50	13-16-20	---	---	3.000	6.000	1 2 3 4 5 6 7 8	■
LSV 100050	C 207 H	hard	100	50	13-16-20	---	---	3.000	6.000	1 2 3 4 5 6 7 8	■
LSV 150050	A 104 W	soft	150	50	13-16-20	47	18	2.000	4.000	1 2 3 4 5 6 7 8	■
LSV 150050	A 106 W	soft	150	50	13-16-20	47	18	2.000	4.000	1 2 3 4 5 6 7 8	■
LSV 150050	A 107 W	soft	150	50	13-16-20	47	18	2.000	4.000	1 2 3 4 5 6 7 8	■
LSV 150050	C 204 W	soft	150	50	13-16-20	47	18	2.000	4.000	1 2 3 4 5 6 7 8	■
LSV 150050	C 206 W	soft	150	50	13-16-20	47	18	2.000	4.000	1 2 3 4 5 6 7 8	■
LSV 150050	C 207 W	soft	150	50	13-16-20	47	18	2.000	4.000	1 2 3 4 5 6 7 8	■
LSV 150050	A 104 M	medium	150	50	13-16-20	47	18	2.000	4.000	1 2 3 4 5 6 7 8	■
LSV 150050	A 106 M	medium	150	50	13-16-20	47	18	2.000	4.000	1 2 3 4 5 6 7 8	■
LSV 150050	A 107 M	medium	150	50	13-16-20	47	18	2.000	4.000	1 2 3 4 5 6 7 8	■
LSV 150050	C 204 M	medium	150	50	13-16-20	47	18	2.000	4.000	1 2 3 4 5 6 7 8	■
LSV 150050	C 206 M	medium	150	50	13-16-20	47	18	2.000	4.000	1 2 3 4 5 6 7 8	■
LSV 150050	C 207 M	medium	150	50	13-16-20	47	18	2.000	4.000	1 2 3 4 5 6 7 8	■
LSV 150050	A 104 H	hard	150	50	13-16-20	47	18	2.000	4.000	1 2 3 4 5 6 7 8	■
LSV 150050	A 106 H	hard	150	50	13-16-20	47	18	2.000	4.000	1 2 3 4 5 6 7 8	■
LSV 150050	A 107 H	hard	150	50	13-16-20	47	18	2.000	4.000	1 2 3 4 5 6 7 8	■
LSV 150050	C 204 H	hard	150	50	13-16-20	47	18	2.000	4.000	1 2 3 4 5 6 7 8	■
LSV 150050	C 206 H	hard	150	50	13-16-20	47	18	2.000	4.000	1 2 3 4 5 6 7 8	■
LSV 150050	C 207 H	hard	150	50	13-16-20	47	18	2.000	4.000	1 2 3 4 5 6 7 8	■
LSV 160050	A 104 W	soft	160	50	13-16-20	47	18	1.900	3.800	1 2 3 4 5 6 7 8	■
LSV 160050	A 106 W	soft	160	50	13-16-20	47	18	1.900	3.800	1 2 3 4 5 6 7 8	■
LSV 160050	A 107 W	soft	160	50	13-16-20	47	18	1.900	3.800	1 2 3 4 5 6 7 8	■
LSV 160050	C 204 W	soft	160	50	13-16-20	47	18	1.900	3.800	1 2 3 4 5 6 7 8	■
LSV 160050	C 206 W	soft	160	50	13-16-20	47	18	1.900	3.800	1 2 3 4 5 6 7 8	■
LSV 160050	C 207 W	soft	160	50	13-16-20	47	18	1.900	3.800	1 2 3 4 5 6 7 8	■
LSV 160050	A 104 M	medium	160	50	13-16-20	47	18	1.900	3.800	1 2 3 4 5 6 7 8	■
LSV 160050	A 106 M	medium	160	50	13-16-20	47	18	1.900	3.800	1 2 3 4 5 6 7 8	■



LSV, Grinding wheels of abrasive fleece, tailor-made solution

Ordering example: LSV 160050 A 107 M Bore 13

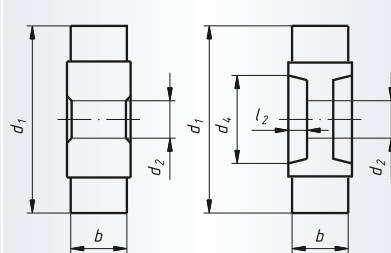

Packing unit:

Minimum ordering quantity 25 pcs. per type
 $v_{max.}$: 35 m/s

Other dimensions, bores or qualities, e.g. "very hard" or "Poly Urethane-foamed" are available on request. Possible diameters 80 mm to max. 400 mm.

A = reg. Aluminium Oxide
 C = Silicon carbide

Description	Grits	Quality	d ₁ mm	b mm	Bore d ₂ mm	recess on both sides d ₄ mm	recess on both sides l ₂ mm	n recom. (1/min)	n max. (1/min)	recommended for	
LSV 160050	A 107 M	medium	160	50	13-16-20	47	18	1.900	3.800	1 2 3 4 5 6 7 8	■
LSV 160050	C 204 M	medium	160	50	13-16-20	47	18	1.900	3.800	1 2 3 4 5 6 7 8	■
LSV 160050	C 206 M	medium	160	50	13-16-20	47	18	1.900	3.800	1 2 3 4 5 6 7 8	■
LSV 160050	C 207 M	medium	160	50	13-16-20	47	18	1.900	3.800	1 2 3 4 5 6 7 8	■
LSV 160050	A 104 H	hard	160	50	13-16-20	47	18	1.900	3.800	1 2 3 4 5 6 7 8	■
LSV 160050	A 106 H	hard	160	50	13-16-20	47	18	1.900	3.800	1 2 3 4 5 6 7 8	■
LSV 160050	A 107 H	hard	160	50	13-16-20	47	18	1.900	3.800	1 2 3 4 5 6 7 8	■
LSV 160050	C 204 H	hard	160	50	13-16-20	47	18	1.900	3.800	1 2 3 4 5 6 7 8	■
LSV 160050	C 206 H	hard	160	50	13-16-20	47	18	1.900	3.800	1 2 3 4 5 6 7 8	■
LSV 160050	C 207 H	hard	160	50	13-16-20	47	18	1.900	3.800	1 2 3 4 5 6 7 8	■
LSV 200025	A 104 W	soft	200	25	20-25-32	71	10	1.500	3.000	1 2 3 4 5 6 7 8	■
LSV 200025	A 106 W	soft	200	25	20-25-32	71	10	1.500	3.000	1 2 3 4 5 6 7 8	■
LSV 200025	A 107 W	soft	200	25	20-25-32	71	10	1.500	3.000	1 2 3 4 5 6 7 8	■
LSV 200025	C 204 W	soft	200	25	20-25-32	71	10	1.500	3.000	1 2 3 4 5 6 7 8	■
LSV 200025	C 206 W	soft	200	25	20-25-32	71	10	1.500	3.000	1 2 3 4 5 6 7 8	■
LSV 200025	C 207 W	soft	200	25	20-25-32	71	10	1.500	3.000	1 2 3 4 5 6 7 8	■
LSV 200025	A 104 M	medium	200	25	20-25-32	71	10	1.500	3.000	1 2 3 4 5 6 7 8	■
LSV 200025	A 106 M	medium	200	25	20-25-32	71	10	1.500	3.000	1 2 3 4 5 6 7 8	■
LSV 200025	A 107 M	medium	200	25	20-25-32	71	10	1.500	3.000	1 2 3 4 5 6 7 8	■
LSV 200025	C 204 M	medium	200	25	20-25-32	71	10	1.500	3.000	1 2 3 4 5 6 7 8	■
LSV 200025	C 206 M	medium	200	25	20-25-32	71	10	1.500	3.000	1 2 3 4 5 6 7 8	■
LSV 200025	C 207 M	medium	200	25	20-25-32	71	10	1.500	3.000	1 2 3 4 5 6 7 8	■
LSV 200025	A 104 H	hard	200	25	20-25-32	71	10	1.500	3.000	1 2 3 4 5 6 7 8	■
LSV 200025	A 106 H	hard	200	25	20-25-32	71	10	1.500	3.000	1 2 3 4 5 6 7 8	■
LSV 200025	A 107 H	hard	200	25	20-25-32	71	10	1.500	3.000	1 2 3 4 5 6 7 8	■
LSV 200025	C 204 H	hard	200	25	20-25-32	71	10	1.500	3.000	1 2 3 4 5 6 7 8	■
LSV 200025	C 206 H	hard	200	25	20-25-32	71	10	1.500	3.000	1 2 3 4 5 6 7 8	■
LSV 200025	C 207 H	hard	200	25	20-25-32	71	10	1.500	3.000	1 2 3 4 5 6 7 8	■
LSV 200050	A 104 W	soft	200	50	20-25-32	71	18	1.500	3.000	1 2 3 4 5 6 7 8	■
LSV 200050	A 106 W	soft	200	50	20-25-32	71	18	1.500	3.000	1 2 3 4 5 6 7 8	■
LSV 200050	A 107 W	soft	200	50	20-25-32	71	18	1.500	3.000	1 2 3 4 5 6 7 8	■
LSV 200050	C 204 W	soft	200	50	20-25-32	71	18	1.500	3.000	1 2 3 4 5 6 7 8	■
LSV 200050	C 206 W	soft	200	50	20-25-32	71	18	1.500	3.000	1 2 3 4 5 6 7 8	■
LSV 200050	C 207 W	soft	200	50	20-25-32	71	18	1.500	3.000	1 2 3 4 5 6 7 8	■
LSV 200050	A 104 M	medium	200	50	20-25-32	71	18	1.500	3.000	1 2 3 4 5 6 7 8	■
LSV 200050	A 106 M	medium	200	50	20-25-32	71	18	1.500	3.000	1 2 3 4 5 6 7 8	■
LSV 200050	A 107 M	medium	200	50	20-25-32	71	18	1.500	3.000	1 2 3 4 5 6 7 8	■
LSV 200050	C 204 M	medium	200	50	20-25-32	71	18	1.500	3.000	1 2 3 4 5 6 7 8	■



Industry

LSV, Grinding wheels of abrasive fleece, tailor-made solution

Ordering example: LSV 200050 C 206 M Bore 20

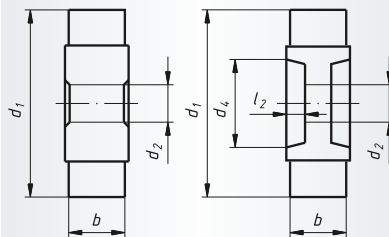

Packing unit:

Minimum ordering quantity 25 pcs. per type
 v_{max} : 35 m/s

Other dimensions, bores or qualities, e.g. "very hard" or "Poly Urethane-foamed" are available on request. Possible diameters 80 mm to max. 400 mm.

A = reg. Aluminium Oxide
 C = Silicon carbide

Description	Grits	Quality	d ₁ mm	b mm	Bore d ₂ mm	recess on both sides d ₄ mm	recess on both sides l ₂ mm	n recom. (1/min)	n max. (1/min)	recommended for	
LSV 200050	C 206 M	medium	200	50	20-25-32	71	18	1.500	3.000	1 2 3 4 5 6 7 8	■
LSV 200050	C 207 M	medium	200	50	20-25-32	71	18	1.500	3.000	1 2 3 4 5 6 7 8	■
LSV 200050	A 104 H	hard	200	50	20-25-32	71	18	1.500	3.000	1 2 3 4 5 6 7 8	■
LSV 200050	A 106 H	hard	200	50	20-25-32	71	18	1.500	3.000	1 2 3 4 5 6 7 8	■
LSV 200050	A 107 H	hard	200	50	20-25-32	71	18	1.500	3.000	1 2 3 4 5 6 7 8	■
LSV 200050	C 204 H	hard	200	50	20-25-32	71	18	1.500	3.000	1 2 3 4 5 6 7 8	■
LSV 200050	C 206 H	hard	200	50	20-25-32	71	18	1.500	3.000	1 2 3 4 5 6 7 8	■
LSV 200050	C 207 H	hard	200	50	20-25-32	71	18	1.500	3.000	1 2 3 4 5 6 7 8	■



Industry

LSM, Flap wheels of abrasive fleece with abrasive cloth, tailor-made solution

Ordering example: LSM 080050 A 104/80 Bore 13

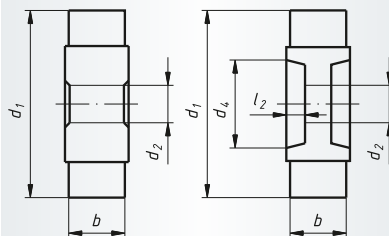

Packing unit:

Minimum ordering quantity 25 pcs. per type
 v_{max} : 35 m/s

Other dimensions, bores or qualities are available on request. Possible diameters 80 mm to max. 400 mm.

A = reg. Aluminium Oxide
 C = Silicon carbide

Description	Grits	d ₁ mm	b mm	Bore d ₂ mm	recess on both sides d ₄ mm	recess on both sides l ₂ mm	n recom. (1/min)	n max. (1/min)	recommended for	
LSM 080050	A 104/80	80	50	10-13-16	---	---	3.800	7.600	1 2 3 4 5 6 7 8	■
LSM 080050	A 106/150	80	50	10-13-16	---	---	3.800	7.600	1 2 3 4 5 6 7 8	■
LSM 080050	A 107/240	80	50	10-13-16	---	---	3.800	7.600	1 2 3 4 5 6 7 8	■
LSM 080050	C 204/80	80	50	10-13-16	---	---	3.800	7.600	1 2 3 4 5 6 7 8	■
LSM 080050	C 206/150	80	50	10-13-16	---	---	3.800	7.600	1 2 3 4 5 6 7 8	■
LSM 080050	C 207/240	80	50	10-13-16	---	---	3.800	7.600	1 2 3 4 5 6 7 8	■
LSM 150050	A 104/80	150	50	13-16-20	47	18	2.000	4.000	1 2 3 4 5 6 7 8	■
LSM 150050	A 106/150	150	50	13-16-20	47	18	2.000	4.000	1 2 3 4 5 6 7 8	■
LSM 150050	A 107/240	150	50	13-16-20	47	18	2.000	4.000	1 2 3 4 5 6 7 8	■
LSM 150050	C 204/80	150	50	13-16-20	47	18	2.000	4.000	1 2 3 4 5 6 7 8	■
LSM 150050	C 206/150	150	50	13-16-20	47	18	2.000	4.000	1 2 3 4 5 6 7 8	■
LSM 150050	C 207/240	150	50	13-16-20	47	18	2.000	4.000	1 2 3 4 5 6 7 8	■
LSM 160050	A 104/80	160	50	13-16-20	47	18	1.900	3.800	1 2 3 4 5 6 7 8	■
LSM 160050	A 106/150	160	50	13-16-20	47	18	1.900	3.800	1 2 3 4 5 6 7 8	■



LSM, Flap wheels of abrasive fleece with abrasive cloth, tailor-made solution

Ordering example: LSM 160050 A 107/240 Bore 16

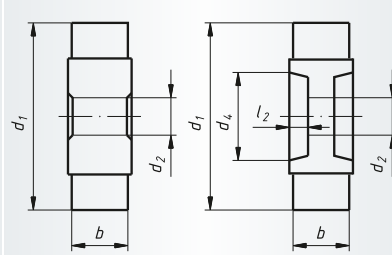

Packing unit:

Minimum ordering quantity 25 pcs. per type

v_{max} : 35 m/s

Other dimensions, bores or qualities are available on request. Possible diameters 80 mm to max. 400 mm.

A = reg. Aluminium Oxide

C = Silicon carbide

Description	Grits	d ₁ mm	b mm	Bore d ₂ mm	recess on both sides d ₄ mm	recess on both sides l ₂ mm	n recom. (1/min)	n max. (1/min)	recommended for	
LSM 160050	A 107/240	160	50	13-16-20	47	18	1.900	3.800	1 2 3 4 5 6 7 8	■
LSM 160050	C 204/80	160	50	13-16-20	47	18	1.900	3.800	1 2 3 4 5 6 7 8	■
LSM 160050	C 206/150	160	50	13-16-20	47	18	1.900	3.800	1 2 3 4 5 6 7 8	■
LSM 160050	C 207/240	160	50	13-16-20	47	18	1.900	3.800	1 2 3 4 5 6 7 8	■
LSM 200050	A 104/80	200	50	20-25-32	71	18	1.500	3.000	1 2 3 4 5 6 7 8	■
LSM 200050	A 106/150	200	50	20-25-32	71	18	1.500	3.000	1 2 3 4 5 6 7 8	■
LSM 200050	A 107/240	200	50	20-25-32	71	18	1.500	3.000	1 2 3 4 5 6 7 8	■
LSM 200050	C 204/80	200	50	20-25-32	71	18	1.500	3.000	1 2 3 4 5 6 7 8	■
LSM 200050	C 206/150	200	50	20-25-32	71	18	1.500	3.000	1 2 3 4 5 6 7 8	■
LSM 200050	C 207/240	200	50	20-25-32	71	18	1.500	3.000	1 2 3 4 5 6 7 8	■





Always the right tool

Tungsten-carbide burrs: Our customers appreciate the precise running smoothness and perfectly finished gears which ensure the utmost chip removal.

Jayesh Shah
Sales Department

www.lukas-erzett.com



FRV, Mops of abrasive fleece

Ordering example: FRV 200050 A 104 Bore 20

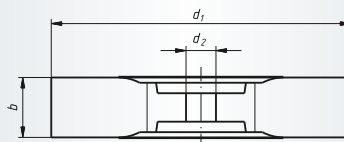

Packing unit:

Minimum ordering quantity 25 pcs. per type

A = reg. Aluminium Oxide

Description	Grits	Quality	d ₁ mm	b mm	d ₂ mm	n recom. (1/min)	n max. (1/min)	recommended for	
FRV 200050	A 104	medium	200	50	20-25-32	1.400	1.900	1 2 3 4 5 6 7 8	■
FRV 200050	A 106	fine	200	50	20-25-32	1.400	1.900	1 2 3 4 5 6 7 8	■
FRV 200050	A 107	very fine	200	50	20-25-32	1.400	1.900	1 2 3 4 5 6 7 8	■
FRV 250050	A 104	medium	250	50	20-25-32	1.100	1.500	1 2 3 4 5 6 7 8	■
FRV 250050	A 106	fine	250	50	20-25-32	1.100	1.500	1 2 3 4 5 6 7 8	■
FRV 250050	A 107	very fine	250	50	20-25-32	1.100	1.500	1 2 3 4 5 6 7 8	■
FRV 300060	A 104	medium	300	60	20-25-32	900	1.200	1 2 3 4 5 6 7 8	■
FRV 300060	A 106	fine	300	60	20-25-32	900	1.200	1 2 3 4 5 6 7 8	■
FRV 300060	A 107	very fine	300	60	20-25-32	900	1.200	1 2 3 4 5 6 7 8	■

LUKAS Fleece Mops are manufactured from abrasive fleece and are used when a satin polish is required on stainless, chrome, nickel and non ferrous metals. They are also ideal for cleaning-up and enhancing painted and varnished surfaces in the wood and plastic industries. Furthermore, they are suited to the manufacture of stainless and aluminium containers supplied to the food industry.

The ideal operating speed lies between 10 – 20 m/s and the fleece mops should

be used with little pressure. They can be used with or without coolant. Operating with coolant extends the life of the fleece mop.

When using water as a coolant a matt surface is achieved; oil produces a satin finish. LUKAS Fleece Mops can be clamped together on a single spindle thus giving the overall width required.

Always the right tool

Cutting discs: Our customers keep asking for thin cuts, quick, cool, precise and free from burrs: Therefore the ROTTLUFF products fit perfectly into our product range.

Georg Klug
Marketing



Flap rolls

228	Qualities and Applications
296	General Information
297	Flap rolls of abrasive cloth, LWL
298	Flap rolls of abrasive fleece, LWW
299	Flap rolls of abrasive fleece/abrasive cloth combination, LWM
300	Sinus-Abrasive rolls of abrasive fleece, LWF
300	Conditioning machine

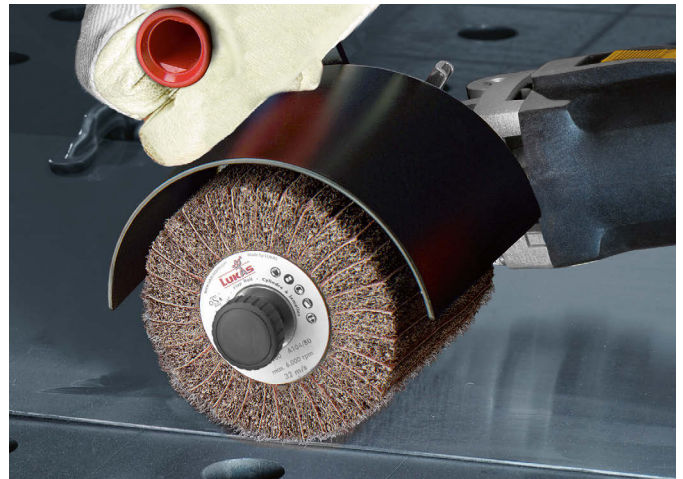

Product line marking

Product lines are labelled in the table header with the appropriate tabs. Further information on page **14** and **15**.

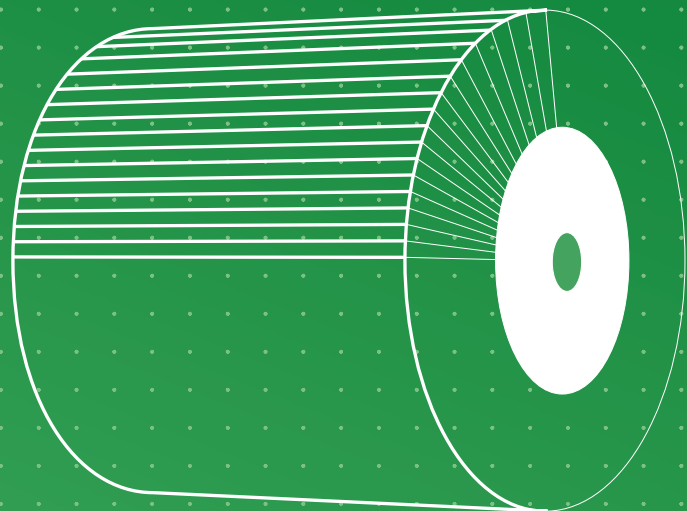

Information

General

These rolls have a nineteen mm bore with four keyways; they are used on hand-held surface conditioning machines.

LWL, Flap rolls of abrasive cloth for conditioning machines

These tools consist of individual flaps which are radially embedded into a resin core.

Please take note of the rotational direction!

Examples of application:

- preparation work
- deburring
- de-rusting
- pre-finishing
- graining
- keying

LWV, Flap rolls of abrasive fleece for conditioning machines

This product type consists of abrasive fleece flaps; the special fleece gives the tool flexibility and conforms to the individual workpiece profile.

Examples of application:

- matting
- conditioning
- polishing
- finishing
- final finishing of the surface

LWF, Sinus-Abrasive rolls of abrasive fleece for conditioning machines

These tools are manufactured from strips of abrasive fleece which are wound in a wave pattern around the core; this configuration achieves an unblemished grained matt surface finish.

The special fleece makes the LWF flexible and conforms to the individual workpiece profile.

Examples of application:

- matting
- conditioning
- polishing
- finishing
- fine surface finishing

LWM, Flap rolls of abrasive fleece with abrasive cloth insert for conditioning machines

Due to the combination of coated abrasive and abrasive fleece, greater stock removal is achieved compared to the product type LWV.

Please take note of the rotational direction!

Examples of application:

- preparation work
- de-rusting
- pre-finishing
- graining
- keying

LWM, flap rolls using TF material

These rolls are supplied with a 19 mm bore and four key-ways, and are particularly suited for stainless steel.

The reverse side of the reinforced abrasive fleece guarantees uniform wear of the fleece and the coated abrasive flaps.

Please take note of the rotational direction!



Industry

LWL, Flap rolls of abrasive cloth for conditioning machines

Ordering example: A2280100500040

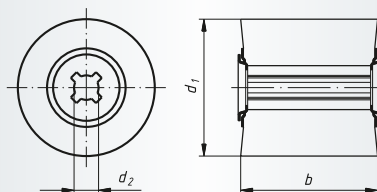

Packing unit:

LWL 100050 = 2 pcs. per type

LWL 100100 = 1 pc. per type

NK = reg. Aluminium Oxide

Machines to suit: page 300

Description	Grits	d ₁ mm	b mm	d ₂ mm	n recom. (1/min)	n max. (1/min)	Product-Number	recommended for	
LWL 100050	NK 40	100	50	19	3.700	6.000	A2280100500040	① ② ③ ④ ⑤ ⑥ ⑦ ⑧	■
LWL 100050	NK 60	100	50	19	3.700	6.000	A2280100500060	① ② ③ ④ ⑤ ⑥ ⑦ ⑧	■
LWL 100050	NK 80	100	50	19	3.700	6.000	A2280100500080	① ② ③ ④ ⑤ ⑥ ⑦ ⑧	■
LWL 100050	NK 60	100	50	19	3.700	6.000	A2280100501060	① ② ③ ④ ⑤ ⑥ ⑦ ⑧	■
LWL 100050	NK 80	100	50	19	3.700	6.000	A2280100501080	① ② ③ ④ ⑤ ⑥ ⑦ ⑧	■
LWL 100100	NK 40	100	100	19	3.700	6.000	A22801001000040	① ② ③ ④ ⑤ ⑥ ⑦ ⑧	■
LWL 100100	NK 60	100	100	19	3.700	6.000	A22801001000060	① ② ③ ④ ⑤ ⑥ ⑦ ⑧	■
LWL 100100	NK 80	100	100	19	3.700	6.000	A22801001000080	① ② ③ ④ ⑤ ⑥ ⑦ ⑧	■



Industry

LWL, Flap rolls of abrasive cloth with thread

Ordering example: A2280100501060

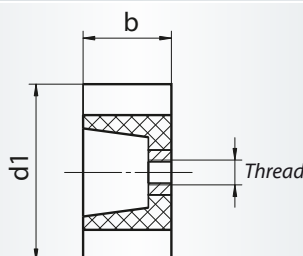

Packing unit:

2 pcs. per type

NK = reg. Aluminium Oxide

Suitable for controlled angle grinders.

Description	Grits	d ₁ mm	b mm	Thread	n recom. (1/min)	n max. (1/min)	Product-Number	recommended for	
LWL 100050	NK 60	100	50	M 14	3.700	6.000	A2280100501060	① ② ③ ④ ⑤ ⑥ ⑦ ⑧	■
LWL 100050	NK 80	100	50	M 14	3.700	6.000	A2280100501080	① ② ③ ④ ⑤ ⑥ ⑦ ⑧	■



LWV, Flap rolls of abrasive fleece for conditioning machines

Ordering example: A2286100500104

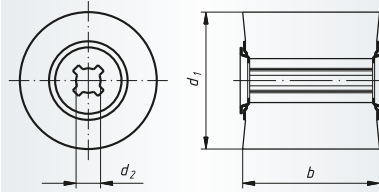

Packing unit:

LWV 100050 = 2 pcs. per type

LWV 100100 = 1 pc. per type

A = reg. Aluminium Oxide

Machines to suit: page 300

Description	Grits	d ₁ mm	b mm	d ₂ mm	n recom. (1/min)	n max. (1/min)	Product-Number	recommended for	
LWV 100050	A 104	100	50	19	2.800	6.000	A2286100500104	1 2 3 4 5 6 7 8	■
LWV 100050	A 106	100	50	19	2.800	6.000	A2286100500106	1 2 3 4 5 6 7 8	■
LWV 100050	A 107	100	50	19	2.800	6.000	A2286100500107	1 2 3 4 5 6 7 8	■
LWV 100100	A 104	100	100	19	2.800	6.000	A22861001000104	1 2 3 4 5 6 7 8	■
LWV 100100	A 106	100	100	19	2.800	6.000	A22861001000106	1 2 3 4 5 6 7 8	■
LWV 100100	A 107	100	100	19	2.800	6.000	A22861001000107	1 2 3 4 5 6 7 8	■



LWV, Flap rolls of abrasive fleece with thread

Ordering example: A2286100501104

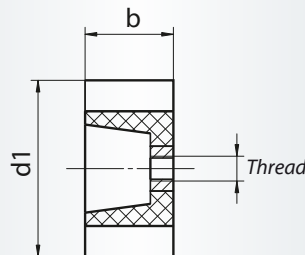

Packing unit:

2 pcs. per type

A = reg. Aluminium Oxide

Suitable for controlled angle grinders.

Description	Grits	d ₁ mm	b mm	Thread	n recom. (1/min)	n max. (1/min)	Product-Number	recommended for	
LWV 100050	A 104	100	50	M 14	2.800	6.000	A2286100501104	1 2 3 4 5 6 7 8	■
LWV 100050	A 106	100	50	M 14	2.800	6.000	A2286100501106	1 2 3 4 5 6 7 8	■
LWV 100050	A 107	100	50	M 14	2.800	6.000	A2286100501107	1 2 3 4 5 6 7 8	■



LWM, Flap rolls of abrasive fleece/abrasive cloth combination

Ordering example: A22881001000120

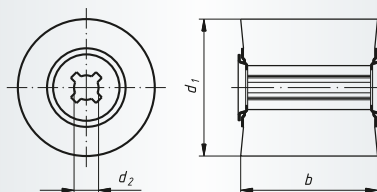

Packing unit:
1 pc. per type
TF = Special quality for INOX
Machines to suit: page 300

Description	Grits	d ₁ mm	b mm	d ₂ mm	n recom. (1/min)	n max. (1/min)	Product-Number	recommended for
LWM 100100	TF 120/80	100	100	19	2.800	6.000	A22881001000120	1 2 3 4 5 6 7 8

Ideal for surface finishing of metalsheet components such as stainless steel sinks and containers



LWM, Flap rolls of abrasive fleece/abrasive cloth combination

Ordering example: A2288100500104

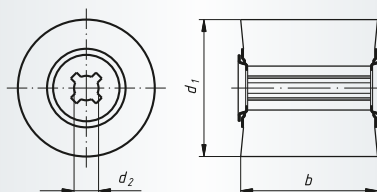

Packing unit:
LWM 100050 = 2 pcs. per type
LWM 100100 = 1 pc. per type
A = reg. Aluminium Oxide
Machines to suit: page 300

Description	Grits	d ₁ mm	b mm	d ₂ mm	n recom. (1/min)	n max. (1/min)	Product-Number	recommended for
LWM 100050	A 104/80	100	50	19	2.800	6.000	A2288100500104	1 2 3 4 5 6 7 8
LWM 100050	A 106/150	100	50	19	2.800	6.000	A2288100500106	1 2 3 4 5 6 7 8
LWM 100050	A 107/240	100	50	19	2.800	6.000	A2288100500107	1 2 3 4 5 6 7 8
LWM 100100	A 104/80	100	100	19	2.800	6.000	A22881001000104	1 2 3 4 5 6 7 8
LWM 100100	A 106/150	100	100	19	2.800	6.000	A22881001000106	1 2 3 4 5 6 7 8
LWM 100100	A 107/240	100	100	19	2.800	6.000	A22881001000107	1 2 3 4 5 6 7 8

300 Flap rolls



Industry

LWM, Flap rolls of abrasive fleece/abrasive cloth combination with thread

Ordering example: A2288100501104

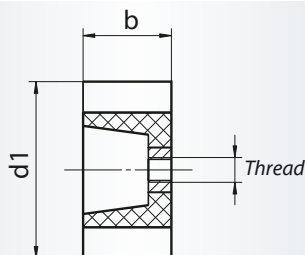

Packing unit:
2 pcs. per type
A = reg. Aluminium Oxide
Suitable for controlled angle grinders.

Description	Grits	d ₁ mm	b mm	Thread	n recom. (1/min)	n max. (1/min)	Product-Number	recommended for	
LWM 100050	A 104/80	100	50	M 14	2.800	6.000	A2288100501104	1 2 3 4 5 6 7 8	■
LWM 100050	A 106/150	100	50	M 14	2.800	6.000	A2288100501106	1 2 3 4 5 6 7 8	■



Industry

LWF, Sinus-Abrasive rolls of abrasive fleece for conditioning machines

Ordering example: A2281100500104

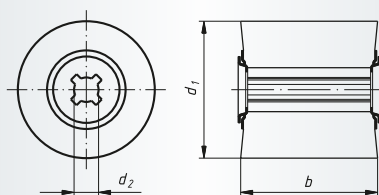

Packing unit:
LWF 100050 = 2 pcs. per type
LWF 100100 = 1 pc. per type
A = reg. Aluminium Oxide
C = Silicon carbide
Machines to suit: page 300

Description	Grits	d ₁ mm	b mm	d ₂ mm	n recom. (1/min)	n max. (1/min)	Product-Number	recommended for	
LWF 100050	A 104	100	50	19	2.800	3.800	A2281100500104	1 2 3 4 5 6 7 8	■
LWF 100050	A 106	100	50	19	2.800	3.800	A2281100500106	1 2 3 4 5 6 7 8	■
LWF 100050	C 208	100	50	19	2.800	3.800	A2281100500208	1 2 3 4 5 6 7 8 9	■
LWF 100100	A 104	100	100	19	2.800	3.800	A22811001000104	1 2 3 4 5 6 7 8	■
LWF 100100	A 106	100	100	19	2.800	3.800	A22811001000106	1 2 3 4 5 6 7 8	■
LWF 100100	C 208	100	100	19	2.800	3.800	A22811001000208	1 2 3 4 5 6 7 8 9	■



Industry

Conditioning machine ESM 1310

Ordering example: A3995ESM1310



Packing unit:
1 pc.
Weight: approx. 2,9 kg
For more technical specifications see page 398.

Description	Idle speed min-1	Power input W	Max. tool diameter Ø mm	Tool width mm	Hole size mm	Product-Number	
ESM 1310	1.300 - 3.050	1.300	120	100	19	A3995ESM1310	■

Abrasive Bands and Mandrels

228 Qualities and Applications

302 General Information

303 Abrasive Bands, cylindrical

309 Mandrels for cylindrical shape

310 Abrasive Bands, cylindrical, unlined

310 Mandrels for cylindrical shape, soft

311 Abrasive Bands, conical

311 Mandrels for conical shape

312 Grinding rolls

312 Mounting device for grinding rolls

313 Finishing belts

381 Power tools

Product line marking

Product lines are labelled in the table header with the appropriate tabs. Further information on page **14** and **15**.

Information

SBZY, Abrasive Bands, cylindrical

LUKAS offers a wide selection of abrasive bands and the corresponding mandrel.

They are available in numerous dimensions and qualities.

Abrasive bands are manufactured from coated abrasive material which is spirally wound onto a cloth backing. They are mounted onto the appropriate mandrel and used on hand-held machines (straight grinders or with flexible shafts)

Examples of application:

- preparation work
- light deburring
- polishing
- surface and profile grinding
- fettling

STZY, Mandrels for cylindrical shape

Our mandrels serve exclusively as the means of mounting the cylindrical abrasive bands. Due to the special slots in the mandrel, the abrasive band is firmly secured to the mandrel by the increasing spindle speed.

SBKE, Abrasive Bands, conical

Conical shaped abrasive bands are in principle identical to the cylindrical type with regards to the construction and application. The large taper allows the grinding of difficult-to-access areas of the workpiece.

STKE, Mandrels for conical shape

Our mandrels serve exclusively as the means of mounting the conical abrasive bands. Due to the special slots in the mandrel, the abrasive band is firmly secured to the mandrel by the increasing spindle speed.

SBZY, Abrasive Bands, cylindrical unlined

These particularly flexible abrasive bands are manufactured from abrasive cloth. They are used on hand-held machines (straight grinders or with flexible shaft) and are mounted onto the appropriate mandrel.

STWS, Mounting device for grinding rolls

These mandrels are produced in a specially soft quality; the 19 mm bore with the four keyways mounted with the abrasive band are used on surface conditioning machines.



High Performance

SBZY, Abrasive Bands, cylindrical shape, Diamond

Ordering example: A301003030126

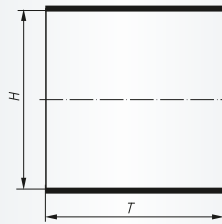
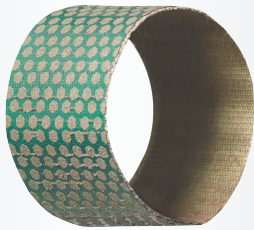

Packing unit:

5 pcs. per type

n_{max}: please refer to band mandrels on page 309

Further dimensions and grit sizes on request.

optimal cutting speed: 10–20 m/s

D = Diamond coated abrasive cloth

Description	Grits	H mm	T mm	Product-Number	recommended for
SBZY 03030	D126	30	30	A301003030126	7 8 9 ■

Diamond abrasive belts are perfect for dealing with hard layers, such as wear protection coatings or armoring made from tungsten, chromium or titanium carbide.

They are also great for other hard materials like glass, ceramic, stone, enamel, carbide or abrasive composite materials from glass or carbon fibre reinforced plastic. Another application is for materials used for turbines and power trains, e.g., hastelloy, inconel and titanium alloys.



High Performance

SBZY, Abrasive Bands, cylindrical shape, Z Power

Ordering example: A241203030036

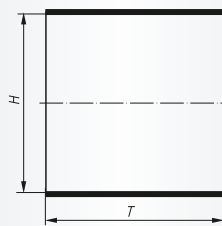
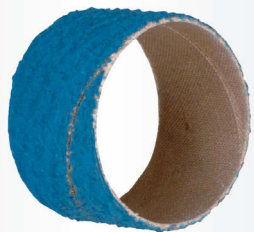

Packing unit:

50 pcs. per type

SBZY 06030 = 25 pcs

n_{max}: please refer to band mandrels on page 309

Further dimensions and grit sizes on request.

Z POWER = zirconia alum. oxide POWER

Description	Grits	H mm	T mm	Product-Number	recommended for
SBZY 03030	Z POWER 36	30	30	A241203030036	2 3 4 5 7 ■
SBZY 03030	Z POWER 50	30	30	A241203030050	2 3 4 5 7 ■
SBZY 03030	Z POWER 60	30	30	A241203030060	2 3 4 5 7 ■
SBZY 03030	Z POWER 80	30	30	A241203030080	2 3 4 5 7 ■
SBZY 04530	Z POWER 36	45	30	A241204530036	2 3 4 5 7 ■
SBZY 04530	Z POWER 50	45	30	A241204530050	2 3 4 5 7 ■
SBZY 04530	Z POWER 60	45	30	A241204530060	2 3 4 5 7 ■
SBZY 04530	Z POWER 80	45	30	A241204530080	2 3 4 5 7 ■
SBZY 06030	Z POWER 36	60	30	A241206030036	2 3 4 5 7 ■
SBZY 06030	Z POWER 50	60	30	A241206030050	2 3 4 5 7 ■
SBZY 06030	Z POWER 60	60	30	A241206030060	2 3 4 5 7 ■
SBZY 06030	Z POWER 80	60	30	A241206030080	2 3 4 5 7 ■



SBZY, Abrasive Bands, cylindrical shape, Ceramic

Ordering example: A240603030040

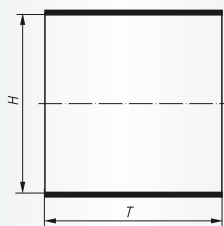
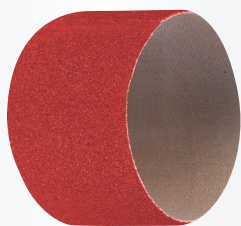

Packing unit:

50 pcs. per type

SBZY 06030 = 25 pcs.

n_{max}: please refer to band mandrels on page 309

Further dimensions and grit sizes on request.

CERAMIC = Abrasive cloth ceramic grain

Description	Grits	H mm	T mm	Product-Number	recommended for	
SBZY 03030	Ceramic 40	30	30	A240603030040	1 2 3 4 5 7	■
SBZY 03030	Ceramic 60	30	30	A240603030060	1 2 3 4 5 7	■
SBZY 04530	Ceramic 40	45	30	A240604530040	1 2 3 4 5 7	■
SBZY 04530	Ceramic 60	45	30	A240604530060	1 2 3 4 5 7	■
SBZY 06030	Ceramic 40	60	30	A240606030040	1 2 3 4 5 7	■
SBZY 06030	Ceramic 60	60	30	A240606030060	1 2 3 4 5 7	■



SBZY, Abrasive Bands, cylindrical shape, reg. Aluminium Oxide

Ordering example: A240000810150

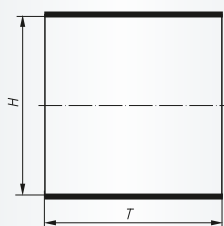

Packing unit:

50 pcs. per type

n_{max}: please refer to band mandrels on page 309

Further dimensions and grit sizes on request.

NK = reg. Aluminium Oxide

Description	Grits	H mm	T mm	Product-Number	recommended for	
SBZY 00810	NK 150	8	10	A240000810150	1 2 3 4 5 6 7 8	■
SBZY 01010	NK 80	10	10	A240001010080	1 2 3 4 5 6 7 8	■
SBZY 01010	NK 150	10	10	A240001010150	1 2 3 4 5 6 7 8	■
SBZY 01010	NK 240	10	10	A240001010240	1 2 3 4 5 6 7 8	■
SBZY 01010	NK 320	10	10	A240001010320	1 2 3 4 5 6 7 8	■
SBZY 01020	NK 80	10	20	A240001020080	1 2 3 4 5 6 7 8	■
SBZY 01020	NK 150	10	20	A240001020150	1 2 3 4 5 6 7 8	■
SBZY 01020	NK 240	10	20	A240001020240	1 2 3 4 5 6 7 8	■
SBZY 01020	NK 320	10	20	A240001020320	1 2 3 4 5 6 7 8	■
SBZY 01210	NK 80	12	10	A240001210080	1 2 3 4 5 6 7 8	■
SBZY 01210	NK 150	12	10	A240001210150	1 2 3 4 5 6 7 8	■
SBZY 01210	NK 240	12	10	A240001210240	1 2 3 4 5 6 7 8	■
SBZY 01213	NK 80	12	13	A240001213080	1 2 3 4 5 6 7 8	■
SBZY 01213	NK 120	12	13	A240001213120	1 2 3 4 5 6 7 8	■
SBZY 01213	NK 240	12	13	A240001213240	1 2 3 4 5 6 7 8	■
SBZY 01225	NK 80	12	25	A240001225080	1 2 3 4 5 6 7 8	■
SBZY 01225	NK 150	12	25	A240001225150	1 2 3 4 5 6 7 8	■
SBZY 01225	NK 240	12	25	A240001225240	1 2 3 4 5 6 7 8	■



Industry

SBZY, Abrasive Bands, cylindrical shape, reg. Aluminium Oxide

Ordering example: A240001225320

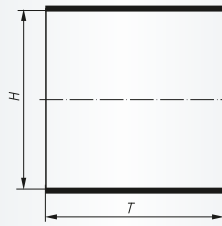

Packing unit:

50 pcs. per type

n max.: please refer to band mandrels on page 309

Further dimensions and grit sizes on request.

NK = reg. Aluminium Oxide

Description	Grits	H mm	T mm	Product-Number	recommended for	
SBZY 01225	NK 320	12	25	A240001225320	① ② ③ ④ ⑤ ⑥ ⑦ ⑧	■
SBZY 01250	NK 80	12	50	A240001250080	① ② ③ ④ ⑤ ⑥ ⑦ ⑧	■
SBZY 01310	NK 80	13	10	A240001310080	① ② ③ ④ ⑤ ⑥ ⑦ ⑧	■
SBZY 01310	NK 150	13	10	A240001310150	① ② ③ ④ ⑤ ⑥ ⑦ ⑧	■
SBZY 01325	NK 80	13	25	A240001325080	① ② ③ ④ ⑤ ⑥ ⑦ ⑧	■
SBZY 01325	NK 150	13	25	A240001325150	① ② ③ ④ ⑤ ⑥ ⑦ ⑧	■
SBZY 01510	NK 60	15	10	A240001510060	① ② ③ ④ ⑤ ⑥ ⑦ ⑧	■
SBZY 01510	NK 80	15	10	A240001510080	① ② ③ ④ ⑤ ⑥ ⑦ ⑧	■
SBZY 01510	NK 150	15	10	A240001510150	① ② ③ ④ ⑤ ⑥ ⑦ ⑧	■
SBZY 01510	NK 240	15	10	A240001510240	① ② ③ ④ ⑤ ⑥ ⑦ ⑧	■
SBZY 01510	NK 320	15	10	A240001510320	① ② ③ ④ ⑤ ⑥ ⑦ ⑧	■
SBZY 01530	NK 40	15	30	A240001530040	① ② ③ ④ ⑤ ⑥ ⑦ ⑧	■
SBZY 01530	NK 50	15	30	A240001530050	① ② ③ ④ ⑤ ⑥ ⑦ ⑧	■
SBZY 01530	NK 60	15	30	A240001530060	① ② ③ ④ ⑤ ⑥ ⑦ ⑧	■
SBZY 01530	NK 80	15	30	A240001530080	① ② ③ ④ ⑤ ⑥ ⑦ ⑧	■
SBZY 01530	NK 120	15	30	A240001530120	① ② ③ ④ ⑤ ⑥ ⑦ ⑧	■
SBZY 01530	NK 150	15	30	A240001530150	① ② ③ ④ ⑤ ⑥ ⑦ ⑧	■
SBZY 01530	NK 240	15	30	A240001530240	① ② ③ ④ ⑤ ⑥ ⑦ ⑧	■
SBZY 01530	NK 320	15	30	A240001530320	① ② ③ ④ ⑤ ⑥ ⑦ ⑧	■
SBZY 01550	NK 50	15	50	A240001550050	① ② ③ ④ ⑤ ⑥ ⑦ ⑧	■
SBZY 01925	NK 50	19	25	A240001925050	① ② ③ ④ ⑤ ⑥ ⑦ ⑧	■
SBZY 01925	NK 60	19	25	A240001925060	① ② ③ ④ ⑤ ⑥ ⑦ ⑧	■
SBZY 01925	NK 80	19	25	A240001925080	① ② ③ ④ ⑤ ⑥ ⑦ ⑧	■
SBZY 01925	NK 150	19	25	A240001925150	① ② ③ ④ ⑤ ⑥ ⑦ ⑧	■
SBZY 02210	NK 150	22	10	A240002210150	① ② ③ ④ ⑤ ⑥ ⑦ ⑧	■
SBZY 02210	NK 240	22	10	A240002210240	① ② ③ ④ ⑤ ⑥ ⑦ ⑧	■
SBZY 02210	NK 320	22	10	A240002210320	① ② ③ ④ ⑤ ⑥ ⑦ ⑧	■
SBZY 02220	NK 50	22	20	A240002220050	① ② ③ ④ ⑤ ⑥ ⑦ ⑧	■
SBZY 02220	NK 60	22	20	A240002220060	① ② ③ ④ ⑤ ⑥ ⑦ ⑧	■
SBZY 02220	NK 80	22	20	A240002220080	① ② ③ ④ ⑤ ⑥ ⑦ ⑧	■
SBZY 02220	NK 150	22	20	A240002220150	① ② ③ ④ ⑤ ⑥ ⑦ ⑧	■
SBZY 02220	NK 240	22	20	A240002220240	① ② ③ ④ ⑤ ⑥ ⑦ ⑧	■
SBZY 02220	NK 320	22	20	A240002220320	① ② ③ ④ ⑤ ⑥ ⑦ ⑧	■
SBZY 02250	NK 50	22	50	A240002250050	① ② ③ ④ ⑤ ⑥ ⑦ ⑧	■
SBZY 02525	NK 40	25	25	A240002525040	① ② ③ ④ ⑤ ⑥ ⑦ ⑧	■
SBZY 02525	NK 50	25	25	A240002525050	① ② ③ ④ ⑤ ⑥ ⑦ ⑧	■
SBZY 02525	NK 60	25	25	A240002525060	① ② ③ ④ ⑤ ⑥ ⑦ ⑧	■
SBZY 02525	NK 80	25	25	A240002525080	① ② ③ ④ ⑤ ⑥ ⑦ ⑧	■
SBZY 02525	NK 150	25	25	A240002525150	① ② ③ ④ ⑤ ⑥ ⑦ ⑧	■



SBZY, Abrasive Bands, cylindrical shape, reg. Aluminium Oxide

Ordering example: A240003020040

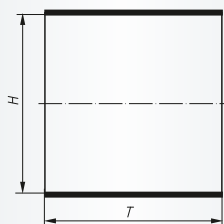

Packing unit:

50 pcs. per type

n max.: please refer to band mandrels on page 309

Further dimensions and grit sizes on request.

NK = reg. Aluminium Oxide

Description	Grits	H mm	T mm	Product-Number	recommended for	
SBZY 03020	NK 40	30	20	A240003020040	1 2 3 4 5 6 7 8	■
SBZY 03020	NK 50	30	20	A240003020050	1 2 3 4 5 6 7 8	■
SBZY 03020	NK 60	30	20	A240003020060	1 2 3 4 5 6 7 8	■
SBZY 03020	NK 80	30	20	A240003020080	1 2 3 4 5 6 7 8	■
SBZY 03020	NK 150	30	20	A240003020150	1 2 3 4 5 6 7 8	■
SBZY 03020	NK 240	30	20	A240003020240	1 2 3 4 5 6 7 8	■
SBZY 03030	NK 40	30	30	A240003030040	1 2 3 4 5 6 7 8	■
SBZY 03030	NK 50	30	30	A240003030050	1 2 3 4 5 6 7 8	■
SBZY 03030	NK 60	30	30	A240003030060	1 2 3 4 5 6 7 8	■
SBZY 03030	NK 80	30	30	A240003030080	1 2 3 4 5 6 7 8	■
SBZY 03030	NK 150	30	30	A240003030150	1 2 3 4 5 6 7 8	■
SBZY 03030	NK 240	30	30	A240003030240	1 2 3 4 5 6 7 8	■
SBZY 03030	NK 320	30	30	A240003030320	1 2 3 4 5 6 7 8	■
SBZY 03825	NK 40	38	25	A240003825040	1 2 3 4 5 6 7 8	■
SBZY 03825	NK 50	38	25	A240003825050	1 2 3 4 5 6 7 8	■
SBZY 03825	NK 60	38	25	A240003825060	1 2 3 4 5 6 7 8	■
SBZY 03825	NK 80	38	25	A240003825080	1 2 3 4 5 6 7 8	■
SBZY 03825	NK 150	38	25	A240003825150	1 2 3 4 5 6 7 8	■
SBZY 04530	NK 40	45	30	A240004530040	1 2 3 4 5 6 7 8	■
SBZY 04530	NK 50	45	30	A240004530050	1 2 3 4 5 6 7 8	■
SBZY 04530	NK 60	45	30	A240004530060	1 2 3 4 5 6 7 8	■
SBZY 04530	NK 80	45	30	A240004530080	1 2 3 4 5 6 7 8	■
SBZY 04530	NK 150	45	30	A240004530150	1 2 3 4 5 6 7 8	■
SBZY 04530	NK 240	45	30	A240004530240	1 2 3 4 5 6 7 8	■
SBZY 04530	NK 320	45	30	A240004530320	1 2 3 4 5 6 7 8	■
SBZY 05125	NK 40	51	25	A240005125040	1 2 3 4 5 6 7 8	■
SBZY 05125	NK 50	51	25	A240005125050	1 2 3 4 5 6 7 8	■
SBZY 05125	NK 60	51	25	A240005125060	1 2 3 4 5 6 7 8	■
SBZY 05125	NK 80	51	25	A240005125080	1 2 3 4 5 6 7 8	■
SBZY 05125	NK 150	51	25	A240005125150	1 2 3 4 5 6 7 8	■
SBZY 06030	NK 40	60	30	A240006030040	1 2 3 4 5 6 7 8	■
SBZY 06030	NK 50	60	30	A240006030050	1 2 3 4 5 6 7 8	■
SBZY 06030	NK 60	60	30	A240006030060	1 2 3 4 5 6 7 8	■
SBZY 06030	NK 80	60	30	A240006030080	1 2 3 4 5 6 7 8	■
SBZY 06030	NK 150	60	30	A240006030150	1 2 3 4 5 6 7 8	■
SBZY 07530	NK 40	75	30	A240007530040	1 2 3 4 5 6 7 8	■
SBZY 07530	NK 50	75	30	A240007530050	1 2 3 4 5 6 7 8	■
SBZY 07530	NK 60	75	30	A240007530060	1 2 3 4 5 6 7 8	■
SBZY 07530	NK 80	75	30	A240007530080	1 2 3 4 5 6 7 8	■



Industry

SBZY, Abrasive Bands, cylindrical shape, reg. Aluminium Oxide

Ordering example: A240007530150

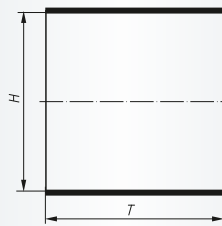

Packing unit:

50 pcs. per type

n max.: please refer to band mandrels on page 309

Further dimensions and grit sizes on request.

NK = reg. Aluminium Oxide

Description	Grits	H mm	T mm	Product-Number	recommended for	
SBZY 07530	NK 150	75	30	A240007530150	① ② ③ ④ ⑤ ⑥ ⑦ ⑧	■
SBZY 10040	NK 40	100	40	A240010040040	① ② ③ ④ ⑤ ⑥ ⑦ ⑧	■
SBZY 10040	NK 50	100	40	A240010040050	① ② ③ ④ ⑤ ⑥ ⑦ ⑧	■
SBZY 10040	NK 60	100	40	A240010040060	① ② ③ ④ ⑤ ⑥ ⑦ ⑧	■
SBZY 10040	NK 80	100	40	A240010040080	① ② ③ ④ ⑤ ⑥ ⑦ ⑧	■
SBZY 10040	NK 150	100	40	A240010040150	① ② ③ ④ ⑤ ⑥ ⑦ ⑧	■



Industry

SBZY, Abrasive Bands, cylindrical shape, Zirconia Aluminium Oxide

Ordering example: A240201325050

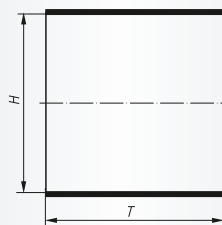
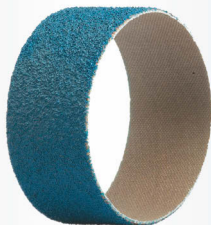

Packing unit:

50 pcs. per type

n max.: please refer to band mandrels on page 309

Further dimensions and grit sizes on request.

ZK = Zirconia Aluminium Oxide

Description	Grits	H mm	T mm	Product-Number	recommended for	
SBZY 01325	ZK 50	13	25	A240201325050	① ② ③ ④ ⑤ ⑦	■
SBZY 01325	ZK 80	13	25	A240201325080	① ② ③ ④ ⑤ ⑦	■
SBZY 01530	ZK 50	15	30	A240201530050	① ② ③ ④ ⑤ ⑦	■
SBZY 01530	ZK 60	15	30	A240201530060	① ② ③ ④ ⑤ ⑦	■
SBZY 01530	ZK 80	15	30	A240201530080	① ② ③ ④ ⑤ ⑦	■
SBZY 01925	ZK 36	19	25	A240201925036	① ② ③ ④ ⑤ ⑦	■
SBZY 01925	ZK 50	19	25	A240201925050	① ② ③ ④ ⑤ ⑦	■
SBZY 01925	ZK 80	19	25	A240201925080	① ② ③ ④ ⑤ ⑦	■
SBZY 02220	ZK 36	22	20	A240202220036	① ② ③ ④ ⑤ ⑦	■
SBZY 02220	ZK 50	22	20	A240202220050	① ② ③ ④ ⑤ ⑦	■
SBZY 02220	ZK 60	22	20	A240202220060	① ② ③ ④ ⑤ ⑦	■
SBZY 02525	ZK 36	25	25	A240202525036	① ② ③ ④ ⑤ ⑦	■
SBZY 02525	ZK 50	25	25	A240202525050	① ② ③ ④ ⑤ ⑦	■
SBZY 02525	ZK 80	25	25	A240202525080	① ② ③ ④ ⑤ ⑦	■
SBZY 03030	ZK 36	30	30	A240203030036	① ② ③ ④ ⑤ ⑦	■
SBZY 03030	ZK 50	30	30	A240203030050	① ② ③ ④ ⑤ ⑦	■
SBZY 03030	ZK 60	30	30	A240203030060	① ② ③ ④ ⑤ ⑦	■



SBZY, Abrasive Bands, cylindrical shape, Zirconia Aluminium Oxide

Ordering example: A240203030080

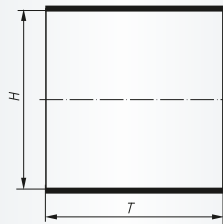

Packing unit:

50 pcs. per type

n_{max}: please refer to band mandrels on page 309

Further dimensions and grit sizes on request.

ZK = Zirconia Aluminium Oxide

Description	Grits	H mm	T mm	Product-Number	recommended for											
SBZY 03030	ZK 80	30	30	A240203030080	1	2	3	4	5	7						■
SBZY 03825	ZK 36	38	25	A240203825036	1	2	3	4	5	7						■
SBZY 03825	ZK 50	38	25	A240203825050	1	2	3	4	5	7						■
SBZY 03825	ZK 80	38	25	A240203825080	1	2	3	4	5	7						■
SBZY 04530	ZK 36	45	30	A240204530036	1	2	3	4	5	7						■
SBZY 04530	ZK 50	45	30	A240204530050	1	2	3	4	5	7						■
SBZY 04530	ZK 60	45	30	A240204530060	1	2	3	4	5	7						■
SBZY 04530	ZK 80	45	30	A240204530080	1	2	3	4	5	7						■
SBZY 05125	ZK 36	51	25	A240205125036	1	2	3	4	5	7						■
SBZY 05125	ZK 50	51	25	A240205125050	1	2	3	4	5	7						■
SBZY 05125	ZK 80	51	25	A240205125080	1	2	3	4	5	7						■
SBZY 06030	ZK 36	60	30	A240206030036	1	2	3	4	5	7						■
SBZY 06030	ZK 50	60	30	A240206030050	1	2	3	4	5	7						■
SBZY 06030	ZK 60	60	30	A240206030060	1	2	3	4	5	7						■
SBZY 06030	ZK 80	60	30	A240206030080	1	2	3	4	5	7						■



STZY, Mandrels cylindrical shape

Ordering example: A2501008103

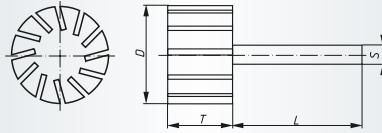
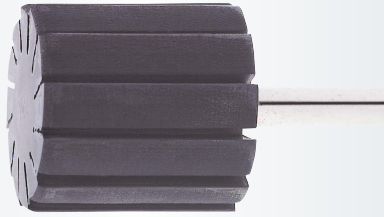

Packing unit:

5 pcs. per type
from Ø 75 mm = 2 pcs. per type
Further dimensions on request.

Description	Type	D mm	T mm	S mm	L mm	n max. (1/min)	Product-Number											
STZY 00810.03	Soft	8	10	3	40	47.500	A2501008103											■
STZY 01010.03	Hard	10	10	3	25	54.000	A2500010103											■
STZY 01010.06	Hard	10	10	6	40	57.000	A2500010106											■
STZY 01020.06	Hard	10	20	6	40	57.000	A2500010206											■
STZY 01210.06	Hard	12	10	6	40	46.500	A2500012106											■
STZY 01213.02	Hard	12	13	2,35	40	26.000	A2500012132											■
STZY 01225.06	Hard	12	25	6	40	46.500	A2500012256											■
STZY 01225.06	Soft	12	25	6	40	31.500	A2501012256											■
STZY 01250.06	Hard	12	50	6	40	31.500	A2500012506											■
STZY 01310.06	Hard	13	10	6	40	44.000	A2500013106											■
STZY 01325.06	Hard	13	25	6	40	44.000	A2500013256											■
STZY 01510.06	Hard	15	10	6	40	38.000	A2500015106											■
STZY 01530.06	Hard	15	30	6	40	38.000	A2500015306											■
STZY 01530.06	Soft	15	30	6	40	25.000	A2501015306											■
STZY 01550.06	Hard	15	50	6	40	25.000	A2500015506											■
STZY 01925.06	Hard	19	25	6	40	30.000	A2500019256											■
STZY 02210.06	Hard	22	10	6	40	26.000	A2500022106											■
STZY 02220.06	Hard	22	20	6	40	26.000	A2500022206											■
STZY 02220.06	Soft	22	20	6	40	17.000	A2501022206											■
STZY 02250.06	Hard	22	50	6	40	17.000	A2500022506											■
STZY 02525.06	Hard	25	25	6	40	22.500	A2500025256											■
STZY 03020.06	Hard	30	20	6	40	19.000	A2500030206											■
STZY 03020.06	Soft	30	20	6	40	12.500	A2501030206											■
STZY 03030.06	Hard	30	30	6	40	19.000	A2500030306											■
STZY 03030.06	Soft	30	30	6	40	12.500	A2501030306											■
STZY 03825.06	Hard	38	25	6	40	15.000	A2500038256											■
STZY 04530.06	Hard	45	30	6	40	13.000	A25000453060001											■
STZY 04530.06	Soft	45	30	6	40	13.000	A25010453060001											■
STZY 05125.06	Hard	51	25	6	40	11.200	A2500051256											■
STZY 06030.06	Hard	60	30	6	40	9.500	A25000603060001											■
STZY 06030.06	Soft	60	30	6	40	6.500	A25010603060001											■
STZY 06030.08	Hard	60	30	8	40	9.500	A2500060308											■
STZY 07530.08	Hard	75	30	8	40	6.500	A25000753080001											■
STZY 10040.08	Soft	100	40	8	40	4.000	A25011004080001											■

The stated maximum operating speed only applies to a maximum overhang L_0 of 20 mm. Other overhang dimensions must be calculated separately.

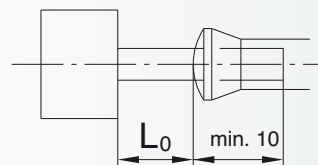



SBZY, Abrasive Bands, cylindrical, unlined

Ordering example: A300003030080

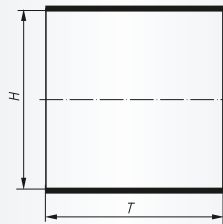
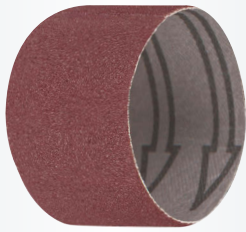

Packing unit:

50 pcs. per type

SBZY 06030 = 25 psc.

n_{max} : please refer to band mandrels on page 309 and 310

NK = reg. Aluminium Oxide

Description	Grits	H mm	T mm	Product-Number	recommended for	
SBZY 03030	NK 80	30	30	A300003030080	① ② ③ ④ ⑤ ⑥ ⑦ ⑧	■
SBZY 03030	NK 120	30	30	A300003030120	① ② ③ ④ ⑤ ⑥ ⑦ ⑧	■
SBZY 03030	NK 150	30	30	A300003030150	① ② ③ ④ ⑤ ⑥ ⑦ ⑧	■
SBZY 04530	NK 80	45	30	A300004530080	① ② ③ ④ ⑤ ⑥ ⑦ ⑧	■
SBZY 04530	NK 120	45	30	A300004530120	① ② ③ ④ ⑤ ⑥ ⑦ ⑧	■
SBZY 04530	NK 150	45	30	A300004530150	① ② ③ ④ ⑤ ⑥ ⑦ ⑧	■

Characteristics:

- Particularly flexible



STZY, Mandrels for cylindrical shape, soft

Ordering example: A2502030306

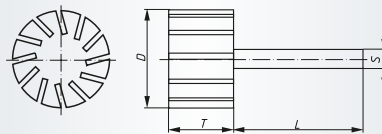
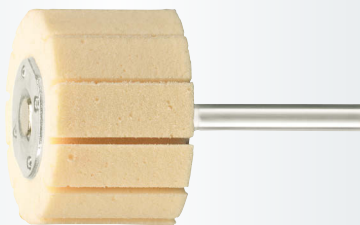

Packing unit:

5 pcs. per type

Description	Type	D mm	T mm	S mm	L mm	n_{max} (1/min)	Product-Number		
STZY 03030.06	Soft	30	30	6	40	9.500	A2502030306		■
STZY 04530.06	Soft	45	30	6	40	6.300	A2502045306		■
STZY 06030.06	Soft	60	30	6	40	4.700	A2502060306		■

The stated maximum operating speed only applies to a maximum overhang L_0 of 20 mm. Other overhang dimensions must be calculated separately.

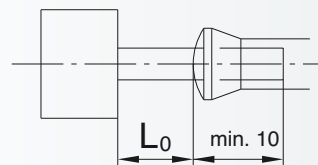



Industry

SBKE, Abrasive Bands, conical shape

Ordering example: A300002063040

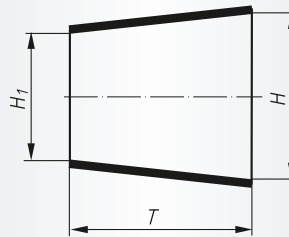

Packing unit:

50 pcs. per type

n_{max} : please refer to band mandrels on page 311

NK = reg. Aluminium Oxide

Description	Grits	H mm	T mm	H ₁ mm	Product-Number	recommended for	
SBKE 02063	NK 40	20	63	14	A300002063040	① ② ③ ④ ⑤ ⑥ ⑦ ⑧	■
SBKE 02063	NK 60	20	63	14	A300002063060	① ② ③ ④ ⑤ ⑥ ⑦ ⑧	■
SBKE 02063	NK 80	20	63	14	A300002063080	① ② ③ ④ ⑤ ⑥ ⑦ ⑧	■
SBKE 02063	NK 150	20	63	14	A300002063150	① ② ③ ④ ⑤ ⑥ ⑦ ⑧	■
SBKE 02930	NK 40	29	30	22	A300002930040	① ② ③ ④ ⑤ ⑥ ⑦ ⑧	■
SBKE 02930	NK 50	29	30	22	A300002930050	① ② ③ ④ ⑤ ⑥ ⑦ ⑧	■
SBKE 02930	NK 60	29	30	22	A300002930060	① ② ③ ④ ⑤ ⑥ ⑦ ⑧	■
SBKE 02930	NK 80	29	30	22	A300002930080	① ② ③ ④ ⑤ ⑥ ⑦ ⑧	■
SBKE 02930	NK 150	29	30	22	A300002930150	① ② ③ ④ ⑤ ⑥ ⑦ ⑧	■
SBKE 03660	NK 40	36	60	22	A300003660040	① ② ③ ④ ⑤ ⑥ ⑦ ⑧	■
SBKE 03660	NK 50	36	60	22	A300003660050	① ② ③ ④ ⑤ ⑥ ⑦ ⑧	■
SBKE 03660	NK 60	36	60	22	A300003660060	① ② ③ ④ ⑤ ⑥ ⑦ ⑧	■
SBKE 03660	NK 80	36	60	22	A300003660080	① ② ③ ④ ⑤ ⑥ ⑦ ⑧	■
SBKE 03660	NK 150	36	60	22	A300003660150	① ② ③ ④ ⑤ ⑥ ⑦ ⑧	■



Industry

STKE, Mandrels for conical shape

Ordering example: A2500020636

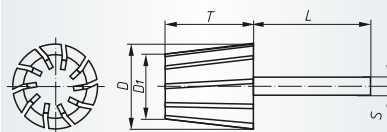
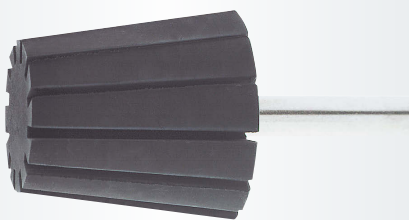

Packing unit:

5 pcs. per type

Description	D mm	T mm	S mm	D ₁ mm	L mm	Type	n_{max} (1/min)	Product-Number	
STKE 02063.06	20	63	6	14	40	Hard	21.000	A2500020636	■
STKE 02930.06	29	30	6	22	40	Hard	21.000	A2500029306	■
STKE 03660.06	36	60	6	22	40	Hard	13.500	A2500036606	■

The stated maximum operating speed only applies to a maximum overhang L_0 of 20 mm. Other overhang dimensions must be calculated separately.

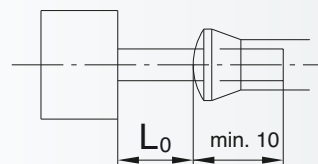



SBZY, Grinding rolls

Ordering example: A2400100100060

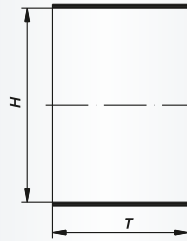
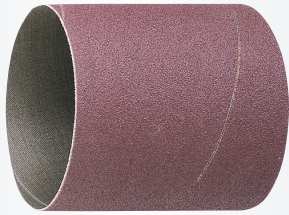

Packing unit:

6 pcs. per type

n_{max} : please refer to band mandrels on page 312

NK = reg. Aluminium Oxide

Description	Grits	H mm	T mm	Product-Number	recommended for	
SBZY 100100	NK 60	100	100	A2400100100060	① ② ③ ④ ⑤ ⑥ ⑦ ⑧	■
SBZY 100100	NK 80	100	100	A2400100100080	① ② ③ ④ ⑤ ⑥ ⑦ ⑧	■
SBZY 100100	NK 120	100	100	A2400100100120	① ② ③ ④ ⑤ ⑥ ⑦ ⑧	■
SBZY 100100	NK 150	100	100	A2400100100150	① ② ③ ④ ⑤ ⑥ ⑦ ⑧	■



STWS, Mounting device for grinding rolls

Ordering example: A2502100100

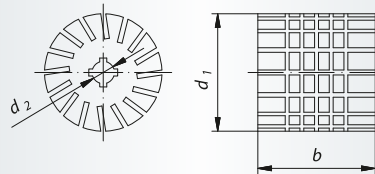

Packing unit:

1 pcs. per type

The bore \varnothing 19 mm has a keyway of 6 mm.

Machines to suit: Page 398

Description	Type	d ₁ mm	b mm	Bore d ₂ mm	n_{max} (1/min)	Product-Number	
STWS 100100	Soft	100	100	19	2.800	A2502100100	■



Industry

SBL, linishing belts

Ordering example: A3000130305040T01



Packing unit:

100 pcs. per type

Used on our pneumatic belt grinder

AMIN 30 BSH

Peripheral speed: 28 m/s

NK = reg. Aluminium Oxide

ZK = Zirconia Alum. Oxide

Description	Grits	B mm	Length mm	Lining	Product-Number	recommended for	
SBLT	ZK 40	13	305	robust-flexible	A3000130305040T01	① ② ③ ④ ⑤ ⑧	■
SBLT	NK 60	13	305	robust-flexible	A3000130305060T	① ② ③ ④ ⑤ ⑧	■
SBLT	ZK 60	13	305	robust-flexible	A3000130305060T01	① ② ③ ④ ⑤ ⑧	■
SBLT	NK 80	13	305	robust-flexible	A3000130305080T	① ② ③ ④ ⑤ ⑧	■
SBLX	NK 80	13	305	robust	A3000130305080X	① ② ③ ④ ⑤ ⑧	■
SBLT	ZK 80	13	305	robust-flexible	A3000130305080T01	① ② ③ ④ ⑤ ⑧	■
SBLT	NK 120	13	305	robust-flexible	A3000130305120T	① ② ③ ④ ⑤ ⑧	■
SBLX	NK 120	13	305	robust	A3000130305120X	① ② ③ ④ ⑤ ⑧	■



Industry

Abrasive belt grinder – insulated

Ordering example: A3993302113



Length: approx. 325 mm
Height: approx. 86 mm
Weight: approx. 0,90 kg
Drive: vane motor

For more technical specifications see page 384.

Description	Valve	Idle speed min ⁻¹	Power consumption KW	Air consumption under load m ³ /min	Belt peripheral speed m/s	Hose-nominal size mm	Product-Number	
AMIN 30 BSH	Lever	30.000	0,3	0,45	28	6	A3993302113	■

Included with the machine:

an abrasive belt mounting arm for long belts in dimension 13 x 305 mm, inlet and exhaust air hoses plus silencer, collet for 6 mm, spanner

Extra equipment:

collets for Ø 3 mm, 4 mm, 5 mm, 1/8", 3/16", 1/4"

Abrasive belt extensions in various sizes (lengths, widths and roll diameters) available ex stock.

Available ex-stock:

long belts 13 x 305 mm

Notes

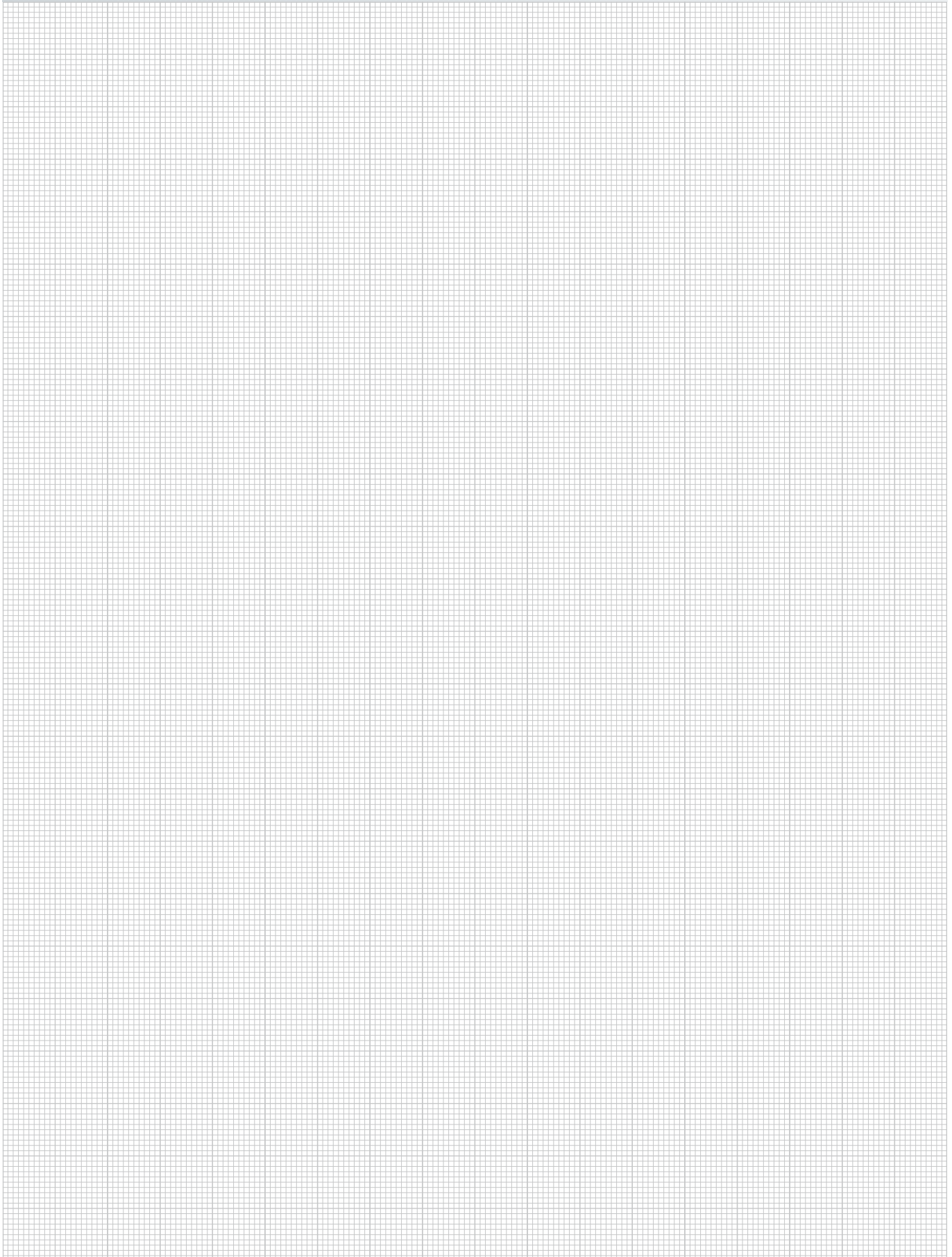
A large rectangular area filled with a fine grid pattern, intended for taking notes. The grid consists of small, uniform squares.

Abrasive Rolls and Mandrels

228 Qualities and Applications

316 General Information

317 Abrasive rolls, cylindrical

318 Abrasive rolls, conical

318 Mandrels

381 Power tools



Product line marking

Product lines are labelled in the table header with the appropriate tabs. Further information on page **14** and **15**.

Information

SRZY, Abrasive rolls, cylindrical and SRKE Abrasive rolls, conical

These abrasive rolls consist of wound coated abrasive material. Their construction guarantees a free-cutting tool; the outer coating wears during the grinding process which then allows new grain particle to be exposed. Please take note of the rotational direction- particularly due to the method of construction!

Examples of applicatin:

- deburring
- preparation work
- fettling

SRTR, Mandrels

Reusable mandrels for the safe mounting of cylindrical and conical abrasive rolls.



SRZY, Abrasive rolls, cylindrical

Ordering example: A240300625080

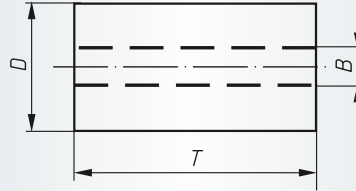
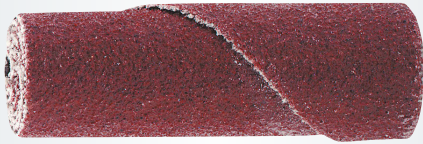

Packing unit:
50 pcs. per type
NK = reg. Aluminium Oxide

Description	Grits	D mm	T mm	B mm	n max. (1/min)	Suitable mandrels	Product-Number	recommended for									
SRZY 0625 B.03	NK 80	6	25	3	24.000	SRTR 3063.03 or SRTR 3063.06	A240300625080	1	2	3	4	5	6	7	8		■
SRZY 0625 B.03	NK 150	6	25	3	24.000	SRTR 3063.03 or SRTR 3063.06	A240300625150	1	2	3	4	5	6	7	8		■
SRZY 0638 B.03	NK 80	6	38	3	24.000	SRTR 3063.03 or SRTR 3063.06	A240300638080	1	2	3	4	5	6	7	8		■
SRZY 0638 B.03	NK 150	6	38	3	24.000	SRTR 3063.03 or SRTR 3063.06	A240300638150	1	2	3	4	5	6	7	8		■
SRZY 1025 B.03	NK 50	10	25	3	24.000	SRTR 3063.03 or SRTR 3063.06	A240301025050	1	2	3	4	5	6	7	8		■
SRZY 1025 B.03	NK 80	10	25	3	24.000	SRTR 3063.03 or SRTR 3063.06	A240301025080	1	2	3	4	5	6	7	8		■
SRZY 1025 B.03	NK 150	10	25	3	24.000	SRTR 3063.03 or SRTR 3063.06	A240301025150	1	2	3	4	5	6	7	8		■
SRZY 1038 B.03	NK 50	10	38	3	24.000	SRTR 3070.06	A240301038050	1	2	3	4	5	6	7	8		■
SRZY 1038 B.03	NK 80	10	38	3	24.000	SRTR 3070.06	A240301038080	1	2	3	4	5	6	7	8		■
SRZY 1038 B.03	NK 150	10	38	3	24.000	SRTR 3070.06	A240301038150	1	2	3	4	5	6	7	8		■
SRZY 1325 B.03	NK 50	13	25	3	24.000	SRTR 3063.06	A240301325050	1	2	3	4	5	6	7	8		■
SRZY 1325 B.03	NK 80	13	25	3	24.000	SRTR 3063.06	A240301325080	1	2	3	4	5	6	7	8		■
SRZY 1325 B.03	NK 150	13	25	3	24.000	SRTR 3063.06	A240301325150	1	2	3	4	5	6	7	8		■
SRZY 1338 B.03	NK 50	13	38	3	24.000	SRTR 3070.06	A240301338050	1	2	3	4	5	6	7	8		■
SRZY 1338 B.03	NK 80	13	38	3	24.000	SRTR 3070.06	A240301338080	1	2	3	4	5	6	7	8		■
SRZY 1338 B.03	NK 150	13	38	3	24.000	SRTR 3070.06	A240301338150	1	2	3	4	5	6	7	8		■
SRZY 2038 B.05	NK 50	20	38	5	16.000	SRTR 5085.06	A240302038050	1	2	3	4	5	6	7	8		■
SRZY 2038 B.05	NK 80	20	38	5	16.000	SRTR 5085.06	A240302038080	1	2	3	4	5	6	7	8		■
SRZY 2038 B.05	NK 150	20	38	5	16.000	SRTR 5085.06	A240302038150	1	2	3	4	5	6	7	8		■
SRZY 2050 B.05	NK 50	20	50	5	16.000	SRTR 5085.06	A240302050050	1	2	3	4	5	6	7	8		■
SRZY 2050 B.05	NK 80	20	50	5	16.000	SRTR 5085.06	A240302050080	1	2	3	4	5	6	7	8		■



SRKE, Abrasive rolls, conical

Ordering example: A240401025050

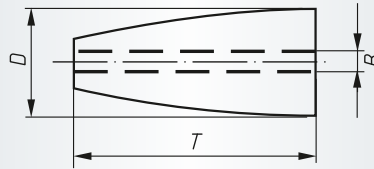

Packing unit:
50 pcs. per type
NK = reg. Aluminium Oxide

Description	Grits	D mm	T mm	B mm	n max. (1/min)	Suitable mandrels	Product-Number	recommended for									
SRKE 1025 B.03	NK 50	10	25	3	24.000	SRTR 3063.03 or SRTR 3063.06	A240401025050	1	2	3	4	5	6	7	8		■
SRKE 1025 B.03	NK 80	10	25	3	24.000	SRTR 3063.03 or SRTR 3063.06	A240401025080	1	2	3	4	5	6	7	8		■
SRKE 1025 B.03	NK 150	10	25	3	24.000	SRTR 3063.03 or SRTR 3063.06	A240401025150	1	2	3	4	5	6	7	8		■
SRKE 1325 B.03	NK 50	13	25	3	24.000	SRTR 3063.06	A240401325050	1	2	3	4	5	6	7	8		■
SRKE 1325 B.03	NK 80	13	25	3	24.000	SRTR 3063.06	A240401325080	1	2	3	4	5	6	7	8		■
SRKE 1325 B.03	NK 150	13	25	3	24.000	SRTR 3063.06	A240401325150	1	2	3	4	5	6	7	8		■
SRKE 1338 B.03	NK 50	13	38	3	24.000	SRTR 3070.06	A240401338050	1	2	3	4	5	6	7	8		■
SRKE 1338 B.03	NK 80	13	38	3	24.000	SRTR 3070.06	A240401338080	1	2	3	4	5	6	7	8		■
SRKE 1338 B.03	NK 150	13	38	3	24.000	SRTR 3070.06	A240401338150	1	2	3	4	5	6	7	8		■
SRKE 1638 B.03	NK 50	16	38	3	16.000	SRTR 3070.06	A240401638050	1	2	3	4	5	6	7	8		■
SRKE 1638 B.03	NK 80	16	38	3	16.000	SRTR 3070.06	A240401638080	1	2	3	4	5	6	7	8		■
SRKE 1638 B.03	NK 150	16	38	3	16.000	SRTR 3070.06	A240401638150	1	2	3	4	5	6	7	8		■
SRKE 2050 B.05	NK 36	20	50	5	16.000	SRTR 5085.06	A240402050036	1	2	3	4	5	6	7	8		■
SRKE 2050 B.05	NK 50	20	50	5	16.000	SRTR 5085.06	A240402050050	1	2	3	4	5	6	7	8		■
SRKE 2050 B.05	NK 80	20	50	5	16.000	SRTR 5085.06	A240402050080	1	2	3	4	5	6	7	8		■
SRKE 2050 B.05	NK 150	20	50	5	16.000	SRTR 5085.06	A240402050150	1	2	3	4	5	6	7	8		■



SRTR, Mandrels

Ordering example: A32030130001

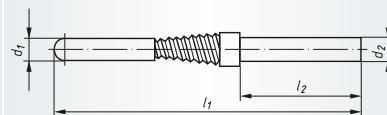

Packing unit:
5 pcs. per type
n max.: please refer to abrasive rolls on page 317–318

Description	Type	d ₁ mm	l ₁ mm	d ₂ mm	l ₂ mm	Product-Number	recommended for										
SRTR 3063.03	browned	3	64	3	27	A32030130001											■
SRTR 3063.06	browned	3	64	6	27	A32030160001											■
SRTR 3070.06	browned	3	70	6	25	A32030260001											■
SRTR 5085.06	browned	5	85	6	35	A32030460001											■

Abrasive Caps and Abrasive Sleeves

228 Qualities and Applications

320 General Information

321 Abrasive caps, cylindrical

322 Mandrel, cylindrical

323 Abrasive caps, cylindrical round nose

324 Mandrel, cylindrical round nose

325 Abrasive caps, cylindrical pointed nose

326 Mandrel, cylindrical pointed nose

327 Abrasive caps, conical round nose

328 Mandrel, conical round nose

329 Abrasive sleeves, tapered

329 Mandrel, tapered

330 Abrasive caps, assortment

381 Power tools

Product line marking

Product lines are labelled in the table header with the appropriate tabs. Further information on page **14** and **15**.

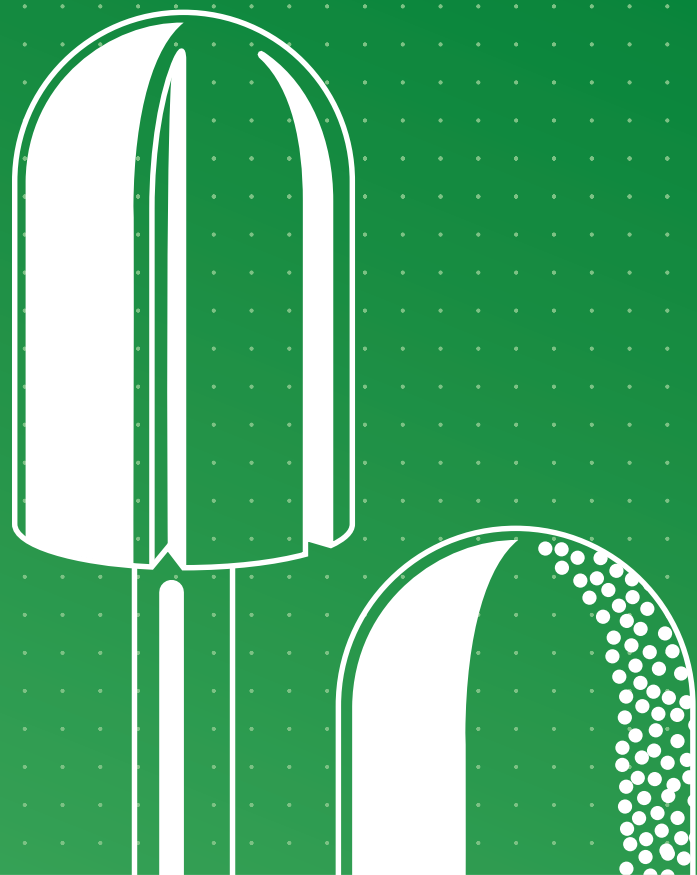

Information

The LUKAS abrasive caps and sleeves are manufactured from high quality coated abrasive material, and are used in conjunction with the appropriate high precision mandrel. We offer a great variety of different tools and mandrels which covers a wide spectrum of applications.

Examples of application:

- fine and extremely fine machining particularly in areas difficult to access
- tool, mould and model making

Maximum operating speed

The maximum operating speed for abrasive caps is stated in the respective table of mandrels. The indicated maximum operating speeds are only valid for a maximum overhang length L_0 of 15 mm. Other overhang dimensions must be calculated separately.

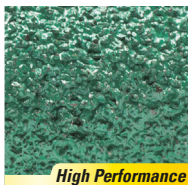
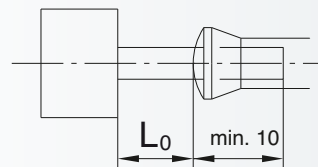

High Performance

Abrasive caps, special, NKS

Special quality for the machining of corrosion and heat-resistant steels for tool and mould making. The top size coating with reactive fillers leads to higher stock removal and increased service life.

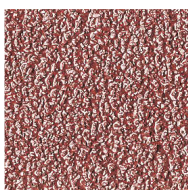

Abrasive caps, universal, NK

Universal quality for the machining of metal, plastics, wood and many other materials.



SKZYS, Abrasive caps special, Cylindrical shape

Ordering example: A21020051080

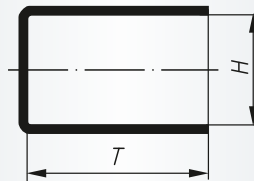

Packing unit:

100 pcs. per type

n max.: please refer to the corresponding mandrel, page 322

NKS = Aluminium Oxide with special coating

Description	Grits	H mm	T mm	Product-Number	recommended for	
SKZYS 0510	NKS 80	5	10	A21020051080	1 2 3 4 5 6 7 8	■
SKZYS 0510	NKS 150	5	10	A21020051150	1 2 3 4 5 6 7 8	■
SKZYS 0712	NKS 60	7	12	A21020071060	1 2 3 4 5 6 7 8	■
SKZYS 0712	NKS 80	7	12	A21020071080	1 2 3 4 5 6 7 8	■
SKZYS 0712	NKS 150	7	12	A21020071150	1 2 3 4 5 6 7 8	■
SKZYS 1015	NKS 60	10	15	A21020101060	1 2 3 4 5 6 7 8	■
SKZYS 1015	NKS 80	10	15	A21020101080	1 2 3 4 5 6 7 8	■
SKZYS 1015	NKS 150	10	15	A21020101150	1 2 3 4 5 6 7 8	■



SKZY, Abrasive caps universal, Cylindrical shape

Ordering example: A21000051080

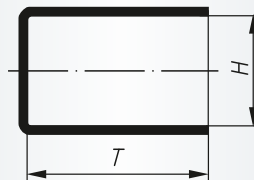
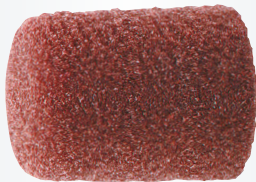

Packing unit:

100 pcs. per type

n max.: please refer to the corresponding mandrel, page 322

NK = reg. Aluminium Oxide

Description	Grits	H mm	T mm	Product-Number	recommended for	
SKZY 0510	NK 80	5	10	A21000051080	1 2 3 4 5 6 7 8	■
SKZY 0510	NK 150	5	10	A21000051150	1 2 3 4 5 6 7 8	■
SKZY 0510	NK 320	5	10	A21000051320	1 2 3 4 5 6 7 8	■
SKZY 0712	NK 60	7	12	A21000071060	1 2 3 4 5 6 7 8	■
SKZY 0712	NK 80	7	12	A21000071080	1 2 3 4 5 6 7 8	■
SKZY 0712	NK 150	7	12	A21000071150	1 2 3 4 5 6 7 8	■
SKZY 0712	NK 320	7	12	A21000071320	1 2 3 4 5 6 7 8	■
SKZY 1015	NK 60	10	15	A21000101060	1 2 3 4 5 6 7 8	■
SKZY 1015	NK 80	10	15	A21000101080	1 2 3 4 5 6 7 8	■
SKZY 1015	NK 150	10	15	A21000101150	1 2 3 4 5 6 7 8	■
SKZY 1015	NK 320	10	15	A21000101320	1 2 3 4 5 6 7 8	■
SKZY 1317	NK 60	13	17	A21000131060	1 2 3 4 5 6 7 8	■
SKZY 1317	NK 80	13	17	A21000131080	1 2 3 4 5 6 7 8	■
SKZY 1317	NK 150	13	17	A21000131150	1 2 3 4 5 6 7 8	■
SKZY 1317	NK 320	13	17	A21000131320	1 2 3 4 5 6 7 8	■
SKZY 1626	NK 60	16	26	A21000161060	1 2 3 4 5 6 7 8	■
SKZY 1626	NK 80	16	26	A21000161080	1 2 3 4 5 6 7 8	■
SKZY 1626	NK 150	16	26	A21000161150	1 2 3 4 5 6 7 8	■
SKZY 1626	NK 320	16	26	A21000161320	1 2 3 4 5 6 7 8	■



High Performance

SKWRS, Abrasive caps special, Cylindrical round nose

Ordering example: A21020052080

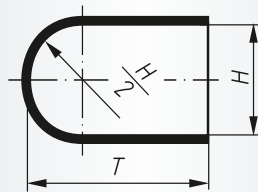

Packing unit:

100 pcs. per type

n max.: please refer to the corresponding mandrel, page 324

NKS = Aluminium Oxide with special coating

Description	Grits	H mm	T mm	Product-Number	recommended for	
SKWRS 0511	NKS 80	5	11	A21020052080	1 2 3 4 5 6 7 8	■
SKWRS 0511	NKS 150	5	11	A21020052150	1 2 3 4 5 6 7 8	■
SKWRS 0713	NKS 60	7	13	A21020072060	1 2 3 4 5 6 7 8	■
SKWRS 0713	NKS 80	7	13	A21020072080	1 2 3 4 5 6 7 8	■
SKWRS 0713	NKS 150	7	13	A21020072150	1 2 3 4 5 6 7 8	■
SKWRS 1015	NKS 60	10	15	A21020102060	1 2 3 4 5 6 7 8	■
SKWRS 1015	NKS 80	10	15	A21020102080	1 2 3 4 5 6 7 8	■
SKWRS 1015	NKS 150	10	15	A21020102150	1 2 3 4 5 6 7 8	■
SKWRS 1319	NKS 60	13	19	A21020132060	1 2 3 4 5 6 7 8	■
SKWRS 1319	NKS 80	13	19	A21020132080	1 2 3 4 5 6 7 8	■
SKWRS 1319	NKS 150	13	19	A21020132150	1 2 3 4 5 6 7 8	■



Industry

SKWR, Abrasive caps universal, Cylindrical round nose

Ordering example: A21000052080

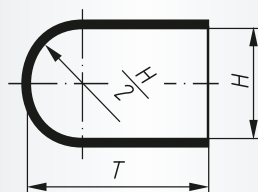

Packing unit:

100 pcs. per type

n max.: please refer to the corresponding mandrel, page 324

NK = reg. Aluminium Oxide

Description	Grits	H mm	T mm	Product-Number	recommended for	
SKWR 0511	NK 80	5	11	A21000052080	1 2 3 4 5 6 7 8	■
SKWR 0511	NK 150	5	11	A21000052150	1 2 3 4 5 6 7 8	■
SKWR 0511	NK 320	5	11	A21000052320	1 2 3 4 5 6 7 8	■
SKWR 0713	NK 60	7	13	A21000072060	1 2 3 4 5 6 7 8	■
SKWR 0713	NK 80	7	13	A21000072080	1 2 3 4 5 6 7 8	■
SKWR 0713	NK 150	7	13	A21000072150	1 2 3 4 5 6 7 8	■
SKWR 0713	NK 320	7	13	A21000072320	1 2 3 4 5 6 7 8	■
SKWR 1015	NK 60	10	15	A21000102060	1 2 3 4 5 6 7 8	■
SKWR 1015	NK 80	10	15	A21000102080	1 2 3 4 5 6 7 8	■
SKWR 1015	NK 150	10	15	A21000102150	1 2 3 4 5 6 7 8	■
SKWR 1015	NK 320	10	15	A21000102320	1 2 3 4 5 6 7 8	■
SKWR 1319	NK 60	13	19	A21000132060	1 2 3 4 5 6 7 8	■
SKWR 1319	NK 80	13	19	A21000132080	1 2 3 4 5 6 7 8	■
SKWR 1319	NK 150	13	19	A21000132150	1 2 3 4 5 6 7 8	■
SKWR 1319	NK 320	13	19	A21000132320	1 2 3 4 5 6 7 8	■



High Performance

SKWKS, Abrasive caps special, Cylindrical pointed nose

Ordering example: A21020053080

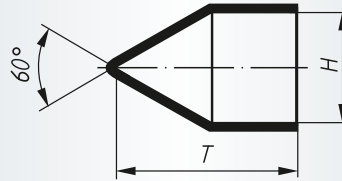
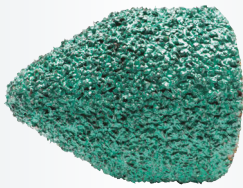

Packing unit:

100 pcs. per type

n max.: please refer to the corresponding mandrel, page 326

NKS = Aluminium Oxide with special coating

Description	Grits	H mm	T mm	Product-Number	recommended for	
SKWKS 0511	NKS 80	5	11	A21020053080	1 2 3 4 5 6 7 8	■
SKWKS 0511	NKS 150	5	11	A21020053150	1 2 3 4 5 6 7 8	■
SKWKS 0713	NKS 60	7	13	A21020073060	1 2 3 4 5 6 7 8	■
SKWKS 0713	NKS 80	7	13	A21020073080	1 2 3 4 5 6 7 8	■
SKWKS 0713	NKS 150	7	13	A21020073150	1 2 3 4 5 6 7 8	■
SKWKS 1015	NKS 60	10	15	A21020103060	1 2 3 4 5 6 7 8	■
SKWKS 1015	NKS 80	10	15	A21020103080	1 2 3 4 5 6 7 8	■
SKWKS 1015	NKS 150	10	15	A21020103150	1 2 3 4 5 6 7 8	■
SKWKS 1319	NKS 60	13	19	A21020133060	1 2 3 4 5 6 7 8	■
SKWKS 1319	NKS 80	13	19	A21020133080	1 2 3 4 5 6 7 8	■
SKWKS 1319	NKS 150	13	19	A21020133150	1 2 3 4 5 6 7 8	■



Industry

SKWK, Abrasive caps universal, Cylindrical pointed nose

Ordering example: A21000053080

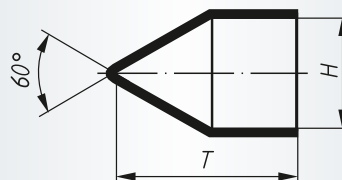

Packing unit:

100 pcs. per type

n max.: please refer to the corresponding mandrel, page 326

NK = reg. Aluminium Oxide

Description	Grits	H mm	T mm	Product-Number	recommended for	
SKWK 0511	NK 80	5	11	A21000053080	1 2 3 4 5 6 7 8	■
SKWK 0511	NK 150	5	11	A21000053150	1 2 3 4 5 6 7 8	■
SKWK 0511	NK 320	5	11	A21000053320	1 2 3 4 5 6 7 8	■
SKWK 0713	NK 60	7	13	A21000073060	1 2 3 4 5 6 7 8	■
SKWK 0713	NK 80	7	13	A21000073080	1 2 3 4 5 6 7 8	■
SKWK 0713	NK 150	7	13	A21000073150	1 2 3 4 5 6 7 8	■
SKWK 0713	NK 320	7	13	A21000073320	1 2 3 4 5 6 7 8	■
SKWK 1015	NK 60	10	15	A21000103060	1 2 3 4 5 6 7 8	■
SKWK 1015	NK 80	10	15	A21000103080	1 2 3 4 5 6 7 8	■
SKWK 1015	NK 150	10	15	A21000103150	1 2 3 4 5 6 7 8	■
SKWK 1015	NK 320	10	15	A21000103320	1 2 3 4 5 6 7 8	■
SKWK 1319	NK 60	13	19	A21000133060	1 2 3 4 5 6 7 8	■
SKWK 1319	NK 80	13	19	A21000133080	1 2 3 4 5 6 7 8	■
SKWK 1319	NK 150	13	19	A21000133150	1 2 3 4 5 6 7 8	■
SKWK 1319	NK 320	13	19	A21000133320	1 2 3 4 5 6 7 8	■



High Performance

SKKES, Abrasive caps special, Conical round nose

Ordering example: A2102163060

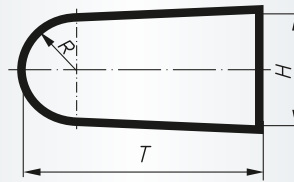

Packing unit:

25 pcs. per type

n max.: please refer to the corresponding mandrel, page 328

NKS = Aluminium Oxide with special coating

Description	Grits	H mm	T mm	≈R mm	Product-Number	recommended for	
SKKES 1632	NKS 60	16	32	7,5	A2102163060	1 2 3 4 5 6 7 8	■
SKKES 1632	NKS 80	16	32	7,5	A2102163080	1 2 3 4 5 6 7 8	■
SKKES 1632	NKS 150	16	32	7,5	A2102163150	1 2 3 4 5 6 7 8	■



Industry

SKKE, Abrasive caps universal, Conical round nose

Ordering example: A2100051080

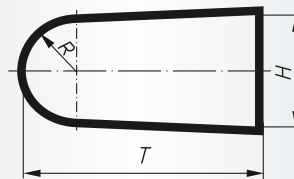

Packing unit:

up to Ø 11 mm = 100 pcs. per type

from Ø 16 mm = 25 pcs. per type

n max.: please refer to the corresponding mandrel, page 328

NK = reg. Aluminium Oxide

Description	Grits	H mm	T mm	≈R mm	Product-Number	recommended for	
SKKE 0515	NK 80	5	15	2	A2100051080	1 2 3 4 5 6 7 8	■
SKKE 0515	NK 150	5	15	2	A2100051150	1 2 3 4 5 6 7 8	■
SKKE 0515	NK 280	5	15	2	A2100051280	1 2 3 4 5 6 7 8	■
SKKE 1125	NK 60	11	25	5	A2100112060	1 2 3 4 5 6 7 8	■
SKKE 1125	NK 80	11	25	5	A2100112080	1 2 3 4 5 6 7 8	■
SKKE 1125	NK 150	11	25	5	A2100112150	1 2 3 4 5 6 7 8	■
SKKE 1125	NK 280	11	25	5	A2100112280	1 2 3 4 5 6 7 8	■
SKKE 1632	NK 60	16	32	7,5	A2100163060	1 2 3 4 5 6 7 8	■
SKKE 1632	NK 80	16	32	7,5	A2100163080	1 2 3 4 5 6 7 8	■
SKKE 1632	NK 150	16	32	7,5	A2100163150	1 2 3 4 5 6 7 8	■
SKKE 1632	NK 280	16	32	7,5	A2100163280	1 2 3 4 5 6 7 8	■
SKKE 2140	NK 60	21	40	9,5	A2100224060	1 2 3 4 5 6 7 8	■
SKKE 2140	NK 80	21	40	9,5	A2100224080	1 2 3 4 5 6 7 8	■
SKKE 2140	NK 150	21	40	9,5	A2100224150	1 2 3 4 5 6 7 8	■
SKKE 2140	NK 280	21	40	9,5	A2100224280	1 2 3 4 5 6 7 8	■



Industry

SHKE, Abrasive sleeves, Conical shape

Ordering example: A2101108080

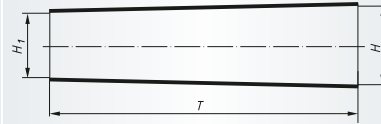

Packing unit:

50 pcs. per type

n_{max} : please refer to the corresponding mandrel, page 329

NK = reg. Aluminium Oxide

Description	Grits	H mm	T mm	H ₁ mm	Product-Number	recommended for	
SHKE 0885	NK 80	8	85	4,5	A2101108080	① ② ③ ④ ⑤ ⑥ ⑦ ⑧	■
SHKE 0885	NK 150	8	85	4,5	A2101108150	① ② ③ ④ ⑤ ⑥ ⑦ ⑧	■
SHKE 1385	NK 80	13	85	9,5	A2101158080	① ② ③ ④ ⑤ ⑥ ⑦ ⑧	■
SHKE 1385	NK 150	13	85	9,5	A2101158150	① ② ③ ④ ⑤ ⑥ ⑦ ⑧	■
SHKE 1885	NK 80	18	85	14,5	A2101208080	① ② ③ ④ ⑤ ⑥ ⑦ ⑧	■
SHKE 1885	NK 150	18	85	14,5	A2101208150	① ② ③ ④ ⑤ ⑥ ⑦ ⑧	■
SHKE 2385	NK 80	23	85	19,5	A2101258080	① ② ③ ④ ⑤ ⑥ ⑦ ⑧	■
SHKE 2385	NK 150	23	85	19,5	A2101258150	① ② ③ ④ ⑤ ⑥ ⑦ ⑧	■



Industry

GTKE, Mandrel, Conical shape

Ordering example: A25001081



Packing unit:

5 pcs. per type

Description	D mm	T mm	L mm	≈R mm	Shank Ø x length mm	n_{max} (1/min)	Product-Number	
GTKE 0885	8	85	40	2	6 X 40	24.000	A25001086	■
GTKE 0885	8	85	40	2	1/4" X 40	24.000	A25001081	■
GTKE 1385	13	85	40	5	6 X 40	17.000	A25001586	■
GTKE 1885	18	85	40	7,5	6 X 40	12.000	A25002086	■
GTKE 2385	23	85	40	9,5	6 X 40	10.000	A25002586	■

For inaccessible areas, use abrasive caps conical shape (see page 327) in conjunction with a mandrel of head length 85 mm.



Abrasive caps-Assortments

Ordering example: A210000065



Packing unit:

1 pc. per type

Assortment containing:

640 pcs. Abrasive Caps

23 pcs. Mandrels

Outside dimension of box: 372 x 189 x 46 mm

NK = reg. Aluminium Oxide

Description	pc.	Contents	Product-Number	recommended for	
WS 65		<p>Abrasive Caps, grit NK 150</p> <p>50 pcs. SKKE 0515</p> <p>100 pcs. of SKZY 0510, SKWR 0511, SKWK 0511</p> <p>50 pcs. of SKZY 0712, SKWR 0713, SKWK 0713</p> <p>20 pcs. of SKZY 1015, SKWR 1015</p> <p>10 pcs. SKKE 1125</p> <p>Abrasive Caps, grit NK 80</p> <p>20 pcs. SKWK 1015</p> <p>10 pcs. of SKZY 1317, SKWR 1319, SKWK 1319, SKKE 1632</p> <p>15 pcs. of SKWK 1626, SKWR 1626</p> <p>Mandrels, Shank 3 mm</p> <p>2 pcs. of GTZY 0510, GTWR 0511, GTWK 0511, GTZY 0712, GTWR 0713, GTWK 0713</p> <p>1 pc. of GTZY 1015, GTWR 1015, GTWK 1015, GTZY 1317, GTWR 1319, GTWK 1319</p> <p>Mandrels, Shank 6 mm</p> <p>1 pc. of GTKE 0515, GTKE 1125, GTWK 1626, GTWR 1626, GTKE 1632</p>	A210000065	<div style="display: flex; justify-content: space-around;"> ①②③④⑤⑥⑦⑧ </div>	■
WS 65 Z		<p>Abrasive Caps, see WS 65</p> <p>Mandrels, Shank 1/8 inch</p> <p>2 pcs. of GTZY 0510, GTWR 0511, GTWK 0511, GTZY 0712, GTWR 0713, GTWK 0713</p> <p>1 pc. of GTZY 1015, GTWR 1015, GTWK 1015, GTZY 1317, GTWR 1319, GTWK 1319</p> <p>Mandrels, Shank 1/4 inch</p> <p>1 pc. of GTKE 0515, GTKE 1125, GTWK 1626, GTWR 1626, GTKE 1632</p>	A210000065Z	<div style="display: flex; justify-content: space-around;"> ①②③④⑤⑥⑦⑧ </div>	■

Abrasive Discs and Mandrels

228	Qualities and Applications	343	Mandrels with plastic thread, quick-change type
332	General Information	344	Abrasive discs, self-adhesive
334	Abrasive discs, quick-change type	345	Mandrels for self-adhesive abrasive discs
339	Mandrels for quick-change abrasive discs	346	Abrasive discs, self-fixing
341	Abrasive discs with plastic thread, quick-change type	346	Mandrels for self-fixing abrasive discs
342	Flap Discs, quick-change type	381	Power tool

Product line marking

Product lines are labelled in the table header with the appropriate tabs. Further information on page **14** and **15**.



Information

Abrasive Discs, quick-change type, PSG/PSR

LUKAS-Abrasive discs- PSG/PSR- are designed for quick mounting; a quick locking metal centre is integrated into the backing of the abrasive disc. A quick twisting movement secures the disc to the mandrel.

The PSG abrasive disc provides us with the most comprehensive selection in this product group.

A choice of diameter, different grit sizes and qualities covering every imaginable application, helps solve your particular grinding problem.

Abrasive Discs, self-adhesive PSK

LUKAS abrasive discs PSK are self-adhesive. The adhesive backing of the disc is covered with a protective foil; after the removal of the foil the disc can be fixed to the rubber mandrel.

The self-adhesive LUKAS abrasive discs can be used on a wide variety of surfaces. After the removal of the disc from the backing, the disc cannot be re-used. The self-adhesive discs are available in various grit sizes of regular aluminium oxide (NK) as detailed on following pages.

Abrasive Discs, self-fixing PSH









LUKAS abrasive discs PSH are self-fixing. The back face of the disc and the front face of the rubber mandrel are coated with Velcro.

The self-fixing LUKAS abrasive discs can be used on both flat and curved surfaces. Due to the velcro fixing, a partly worn disc can easily be removed and re-used at a later date.

The self-fixing abrasive discs are available in various grit sizes of regular aluminium oxide (NK), as detailed on following pages.

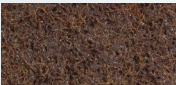

PSG, Qualities and Applications

Quality		Characteristics	Applications	Page
 NK	Abrasive cloth with reg. Aluminium Oxide	tough grain	Universal grinding and deburring	334
 NKE	Abrasive cloth using reg. Aluminium Oxide with special coating	tough grain	Due to the reinforcement suited even for highest demands and edge working.	335
 ZK	Abrasive cloth with Zirconia Alum. Oxide	very tough and resilient grain	Ideal for hastelloy, inconel, stainless and steels difficult to machine.	336
 Z POWER	Zirconia Alum. Oxide with active grinding additives	optimum stock removal rate, excellent tool life	Ideal for stainless. Special topsize coating prevents clogging.	336
 Ceramic	Abrasive cloth ceramic grain	optimum stock removal rate without shredding of grain. Very stable due to reinforced backing. Cool cutting	Ideal for stainless and nickel alloys.	337
 SIC	Abrasive cloth with Silicon carbide	cool cutting; special quality for the aircraft industry	Ideal for titanium, titanium alloys and aluminium (aerospace industry). Also suitable for plastic and ceramic materials.	337
  	Fleece Reg. Aluminium oxide coarse/brown medium/red-brown fine/blue	Polishing effect through the fibre structure, constant working results due to steadily discharge of abrasive particles. Outstanding tool life.	Ideal for removing rust or paint, scratches and pre-machining marks. A general improvement of the surface finish.	338

334 Abrasive discs, quick-change



Industry

PSG, Abrasive discs, quick-change, reg. Aluminium Oxide

Ordering example: A3371020060

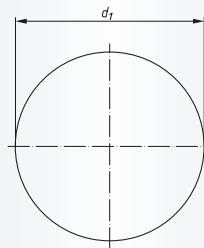
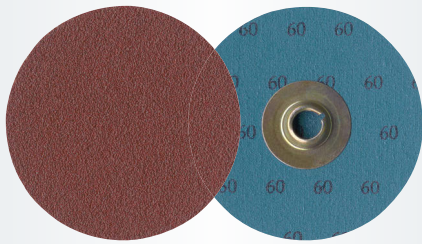

Packing unit:
100 pcs. per type
from Ø 75 mm: 50 pcs. per type

Description	Grits	d ₁ mm	n max. (1/min)	Suitable carriers	Product-Number	recommended for	
PSG 020	NK 60	19	40.000	GTG 020	A3371020060	① ② ③ ④ ⑤ ⑥ ⑦ ⑧	■
PSG 020	NK 80	19	40.000	GTG 020	A3371020080	① ② ③ ④ ⑤ ⑥ ⑦ ⑧	■
PSG 020	NK 120	19	40.000	GTG 020	A3371020120	① ② ③ ④ ⑤ ⑥ ⑦ ⑧	■
PSG 025	NK 36	25	40.000	GTG 025	A3371025036	① ② ③ ④ ⑤ ⑥ ⑦ ⑧	■
PSG 025	NK 60	25	40.000	GTG 025	A3371025060	① ② ③ ④ ⑤ ⑥ ⑦ ⑧	■
PSG 025	NK 80	25	40.000	GTG 025	A3371025080	① ② ③ ④ ⑤ ⑥ ⑦ ⑧	■
PSG 025	NK 120	25	40.000	GTG 025	A3371025120	① ② ③ ④ ⑤ ⑥ ⑦ ⑧	■
PSG 038	NK 36	38	30.000	GTG 038	A3371038036	① ② ③ ④ ⑤ ⑥ ⑦ ⑧	■
PSG 038	NK 60	38	30.000	GTG 038	A3371038060	① ② ③ ④ ⑤ ⑥ ⑦ ⑧	■
PSG 038	NK 80	38	30.000	GTG 038	A3371038080	① ② ③ ④ ⑤ ⑥ ⑦ ⑧	■
PSG 038	NK 120	38	30.000	GTG 038	A3371038120	① ② ③ ④ ⑤ ⑥ ⑦ ⑧	■
PSG 038	NK 180	38	30.000	GTG 038	A3371038180	① ② ③ ④ ⑤ ⑥ ⑦ ⑧	■
PSG 038	NK 240	38	30.000	GTG 038	A3371038240	① ② ③ ④ ⑤ ⑥ ⑦ ⑧	■
PSG 050	NK 36	51	30.000	GTG 038 and GTG 050	A3371050036	① ② ③ ④ ⑤ ⑥ ⑦ ⑧	■
PSG 050	NK 50	51	30.000	GTG 038 and GTG 050	A3371050050	① ② ③ ④ ⑤ ⑥ ⑦ ⑧	■
PSG 050	NK 60	51	30.000	GTG 038 and GTG 050	A3371050060	① ② ③ ④ ⑤ ⑥ ⑦ ⑧	■
PSG 050	NK 80	51	30.000	GTG 038 and GTG 050	A3371050080	① ② ③ ④ ⑤ ⑥ ⑦ ⑧	■
PSG 050	NK 120	51	30.000	GTG 038 and GTG 050	A3371050120	① ② ③ ④ ⑤ ⑥ ⑦ ⑧	■
PSG 050	NK 180	51	30.000	GTG 038 and GTG 050	A3371050180	① ② ③ ④ ⑤ ⑥ ⑦ ⑧	■
PSG 050	NK 240	51	30.000	GTG 038 and GTG 050	A3371050240	① ② ③ ④ ⑤ ⑥ ⑦ ⑧	■
PSG 075	NK 36	76	20.000	GTG 075	A3371075036	① ② ③ ④ ⑤ ⑥ ⑦ ⑧	■
PSG 075	NK 60	76	20.000	GTG 075	A3371075060	① ② ③ ④ ⑤ ⑥ ⑦ ⑧	■
PSG 075	NK 80	76	20.000	GTG 075	A3371075080	① ② ③ ④ ⑤ ⑥ ⑦ ⑧	■
PSG 075	NK 120	76	20.000	GTG 075	A3371075120	① ② ③ ④ ⑤ ⑥ ⑦ ⑧	■
PSG 075	NK 180	76	20.000	GTG 075	A3371075180	① ② ③ ④ ⑤ ⑥ ⑦ ⑧	■



PSG, Abrasive discs, quick-change, reg. Aluminium Oxide with special coating

Ordering example: A3352025060

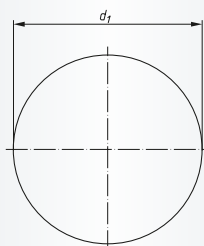
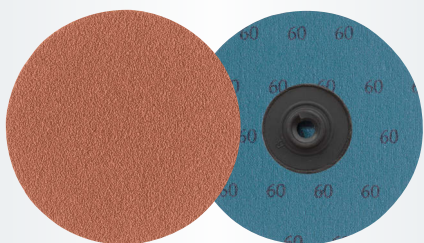

Packing unit:
100 Scs. per type,
from Ø 75 mm: 50 Spcs. per type

Description	Grits	d ₁ mm	n max. (1/min)	Suitable carriers	Product-Number	recommended for	
PSG 025	NKE 60	25	40.000	GTG 025	A3352025060	① ② ③ ④ ⑤ ⑥ ⑦ ⑧	■
PSG 025	NKE 80	25	40.000	GTG 025	A3352025080	① ② ③ ④ ⑤ ⑥ ⑦ ⑧	■
PSG 025	NKE 120	25	40.000	GTG 025	A3352025120	① ② ③ ④ ⑤ ⑥ ⑦ ⑧	■
PSG 025	NKE 180	25	40.000	GTG 025	A3352025180	① ② ③ ④ ⑤ ⑥ ⑦ ⑧	■
PSG 025	NKE 240	25	40.000	GTG 025	A3352025240	① ② ③ ④ ⑤ ⑥ ⑦ ⑧	■
PSG 038	NKE 60	38	30.000	GTG 038	A3352038060	① ② ③ ④ ⑤ ⑥ ⑦ ⑧	■
PSG 038	NKE 80	38	30.000	GTG 038	A3352038080	① ② ③ ④ ⑤ ⑥ ⑦ ⑧	■
PSG 038	NKE 120	38	30.000	GTG 038	A3352038120	① ② ③ ④ ⑤ ⑥ ⑦ ⑧	■
PSG 050	NKE 36	51	30.000	GTG 038 and GTG 050	A3352050036	① ② ③ ④ ⑤ ⑥ ⑦ ⑧	■
PSG 050	NKE 60	51	30.000	GTG 038 and GTG 050	A3352050060	① ② ③ ④ ⑤ ⑥ ⑦ ⑧	■
PSG 050	NKE 80	51	30.000	GTG 038 and GTG 050	A3352050080	① ② ③ ④ ⑤ ⑥ ⑦ ⑧	■
PSG 050	NKE 120	51	30.000	GTG 038 and GTG 050	A3352050120	① ② ③ ④ ⑤ ⑥ ⑦ ⑧	■
PSG 050	NKE 180	51	30.000	GTG 038 and GTG 050	A3352050180	① ② ③ ④ ⑤ ⑥ ⑦ ⑧	■
PSG 050	NKE 240	51	30.000	GTG 038 and GTG 050	A3352050240	① ② ③ ④ ⑤ ⑥ ⑦ ⑧	■
PSG 075	NKE 60	76	20.000	GTG 075	A3352075060	① ② ③ ④ ⑤ ⑥ ⑦ ⑧	■
PSG 075	NKE 80	76	20.000	GTG 075	A3352075080	① ② ③ ④ ⑤ ⑥ ⑦ ⑧	■



Industry

PSG, Abrasive discs, quick-change, Zirconia Alum. Oxide

Ordering example: A3353025060

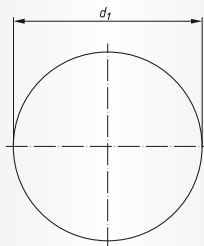
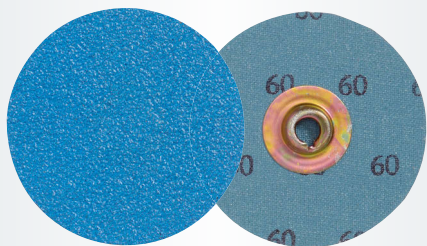

Packing unit:
100 pcs. per type
from Ø 75 mm: 50 pcs. per type

Description	Quality Grits	d ₁ mm	n max. (1/min)	Suitable carriers	Product-Number	recommended for	
PSG 025	ZK 60	25	40.000	GTG 025	A3353025060	1 2 3 4 5 7	■
PSG 025	ZK 80	25	40.000	GTG 025	A3353025080	1 2 3 4 5 7	■
PSG 038	ZK 60	38	30.000	GTG 038	A3353038060	1 2 3 4 5 7	■
PSG 038	ZK 80	38	30.000	GTG 038	A3353038080	1 2 3 4 5 7	■
PSG 050	ZK 36	51	30.000	GTG 038 and GTG 050	A3353050036	1 2 3 4 5 7	■
PSG 050	ZK 60	51	30.000	GTG 038 and GTG 050	A3353050060	1 2 3 4 5 7	■
PSG 050	ZK 80	51	30.000	GTG 038 and GTG 050	A3353050080	1 2 3 4 5 7	■
PSG 075	ZK 36	76	20.000	GTG 075	A3353075036	1 2 3 4 5 7	■
PSG 075	ZK 60	76	20.000	GTG 075	A3353075060	1 2 3 4 5 7	■
PSG 075	ZK 80	76	20.000	GTG 075	A3353075080	1 2 3 4 5 7	■



Industry

PSG, Abrasive discs, quick-change, Zirconia Alum. Oxide with active grinding additives

Ordering example: A3377038036

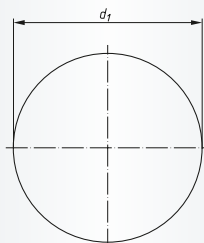
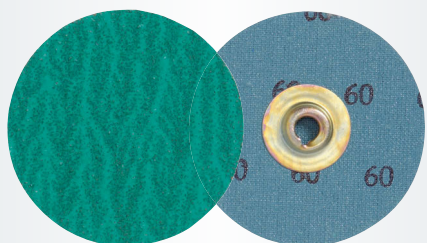

Packing unit:
100 pcs. per type
from Ø 75 mm: 50 pcs. per type

Description	Quality Grits	d ₁ mm	n max. (1/min)	Suitable carriers	Product-Number	recommended for	
PSG 038	Z Power 36	38	30.000	GTG 038	A3377038036	1 2 3 4 5 7	■
PSG 038	Z Power 60	38	30.000	GTG 038	A3377038060	1 2 3 4 5 7	■
PSG 038	Z Power 80	38	30.000	GTG 038	A3377038080	1 2 3 4 5 7	■
PSG 038	Z Power 120	38	30.000	GTG 038	A3377038120	1 2 3 4 5 7	■
PSG 050	Z Power 36	51	30.000	GTG 038 and GTG 050	A3377050036	1 2 3 4 5 7	■
PSG 050	Z Power 60	51	30.000	GTG 038 and GTG 050	A3377050060	1 2 3 4 5 7	■
PSG 050	Z Power 80	51	30.000	GTG 038 and GTG 050	A3377050080	1 2 3 4 5 7	■
PSG 050	Z Power 120	51	30.000	GTG 038 and GTG 050	A3377050120	1 2 3 4 5 7	■
PSG 075	Z Power 36	76	20.000	GTG 075	A3377075036	1 2 3 4 5 7	■
PSG 075	Z Power 60	76	20.000	GTG 075	A3377075060	1 2 3 4 5 7	■
PSG 075	Z Power 80	76	20.000	GTG 075	A3377075080	1 2 3 4 5 7	■
PSG 075	Z Power 120	76	20.000	GTG 075	A3377075120	1 2 3 4 5 7	■



Industry

PSG, Abrasive discs, quick-change, Silicon carbide

Ordering example: A3378038036

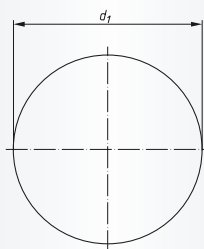
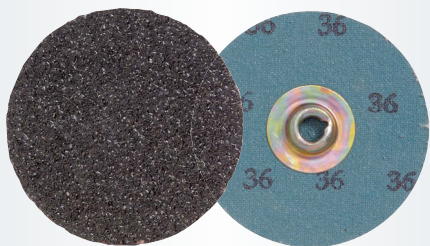

Packing unit:
100 pcs. per type
from Ø 75 mm: 50 pcs. per type

Description	Quality Grits	d ₁ mm	n max. (1/min)	Suitable carriers	Product-Number	recommended for	
PSG 038	SIC 36	38	30.000	GTG 038	A3378038036	① ② ③ ④ ⑤ ⑥ ⑦ ⑧ ⑨	■
PSG 038	SIC 60	38	30.000	GTG 038	A3378038060	① ② ③ ④ ⑤ ⑥ ⑦ ⑧ ⑨	■
PSG 038	SIC 80	38	30.000	GTG 038	A3378038080	① ② ③ ④ ⑤ ⑥ ⑦ ⑧ ⑨	■
PSG 038	SIC 120	38	30.000	GTG 038	A3378038120	① ② ③ ④ ⑤ ⑥ ⑦ ⑧ ⑨	■
PSG 050	SIC 36	51	30.000	GTG 038 and GTG 050	A3378050036	① ② ③ ④ ⑤ ⑥ ⑦ ⑧ ⑨	■
PSG 050	SIC 60	51	30.000	GTG 038 and GTG 050	A3378050060	① ② ③ ④ ⑤ ⑥ ⑦ ⑧ ⑨	■
PSG 050	SIC 80	51	30.000	GTG 038 and GTG 050	A3378050080	① ② ③ ④ ⑤ ⑥ ⑦ ⑧ ⑨	■
PSG 050	SIC 120	51	30.000	GTG 038 and GTG 050	A3378050120	① ② ③ ④ ⑤ ⑥ ⑦ ⑧ ⑨	■
PSG 075	SIC 36	76	20.000	GTG 075	A3378075036	① ② ③ ④ ⑤ ⑥ ⑦ ⑧ ⑨	■
PSG 075	SIC 60	76	20.000	GTG 075	A3378075060	① ② ③ ④ ⑤ ⑥ ⑦ ⑧ ⑨	■
PSG 075	SIC 80	76	20.000	GTG 075	A3378075080	① ② ③ ④ ⑤ ⑥ ⑦ ⑧ ⑨	■



Industry

PSG, Abrasive discs, quick-change, Ceramic grain

Ordering example: A3379038036

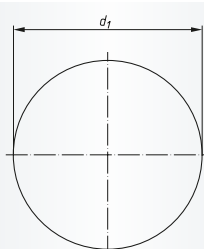
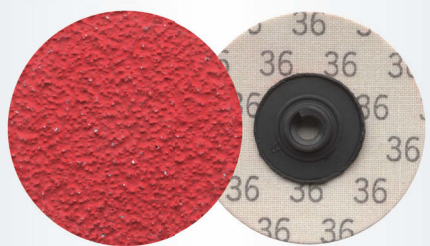

Packing unit:
100 pcs. per type
from Ø 75 mm: 50 pcs. per type

Description	Quality Grits	d ₁ mm	n max. (1/min)	Suitable carriers	Product-Number	recommended for	
PSG 038	Ceramic 36	38	30.000	GTG 038	A3379038036	② ③ ④ ⑤ ⑦	■
PSG 038	Ceramic 60	38	30.000	GTG 038	A3379038060	② ③ ④ ⑤ ⑦	■
PSG 038	Ceramic 80	38	30.000	GTG 038	A3379038080	② ③ ④ ⑤ ⑦	■
PSG 038	Ceramic 120	38	30.000	GTG 038	A3379038120	② ③ ④ ⑤ ⑦	■
PSG 050	Ceramic 36	51	30.000	GTG 038 and GTG 050	A3379050036	② ③ ④ ⑤ ⑦	■
PSG 050	Ceramic 60	51	30.000	GTG 038 and GTG 050	A3379050060	② ③ ④ ⑤ ⑦	■
PSG 050	Ceramic 80	51	30.000	GTG 038 and GTG 050	A3379050080	② ③ ④ ⑤ ⑦	■
PSG 050	Ceramic 120	51	30.000	GTG 038 and GTG 050	A3379050120	② ③ ④ ⑤ ⑦	■
PSG 075	Ceramic 36	76	20.000	GTG 075	A3379075036	② ③ ④ ⑤ ⑦	■
PSG 075	Ceramic 60	76	20.000	GTG 075	A3379075060	② ③ ④ ⑤ ⑦	■
PSG 075	Ceramic 80	76	20.000	GTG 075	A3379075080	② ③ ④ ⑤ ⑦	■
PSG 075	Ceramic 120	76	20.000	GTG 075	A3379075120	② ③ ④ ⑤ ⑦	■



PSG, Abrasive discs, quick-change, Fleece Reg. Aluminium oxide

Ordering example: A3374038005

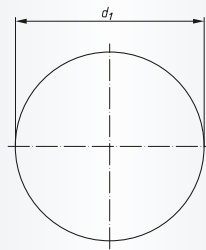

Packing unit:
50 pcs. per type,
from Ø 75 mm: 25 pcs. per type

Description	Quality Grits	d ₁ mm	n max. (1/min)	Suitable carriers	Product-Number	recommended for	
PSG 038	Fleece fine	38	10.000	GTG 038	A3374038005	① ② ③ ④ ⑤ ⑥ ⑦ ⑧	■
PSG 038	Fleece coarse	38	10.000	GTG 038	A3374038004	① ② ③ ④ ⑤ ⑥ ⑦ ⑧	■
PSG 038	Fleece medium	38	10.000	GTG 038	A3374038002	① ② ③ ④ ⑤ ⑥ ⑦ ⑧	■
PSG 050	Fleece fine	51	8.000	GTG 038 and GTG 050	A3374050005	① ② ③ ④ ⑤ ⑥ ⑦ ⑧	■
PSG 050	Fleece coarse	51	8.000	GTG 038 and GTG 050	A3374050004	① ② ③ ④ ⑤ ⑥ ⑦ ⑧	■
PSG 050	Fleece medium	51	8.000	GTG 038 and GTG 050	A3374050002	① ② ③ ④ ⑤ ⑥ ⑦ ⑧	■
PSG 075	Fleece fine	75	5.500	GTG 075	A3374075005	① ② ③ ④ ⑤ ⑥ ⑦ ⑧	■
PSG 075	Fleece coarse	75	5.500	GTG 075	A3374075004	① ② ③ ④ ⑤ ⑥ ⑦ ⑧	■
PSG 075	Fleece medium	75	5.500	GTG 075	A3374075002	① ② ③ ④ ⑤ ⑥ ⑦ ⑧	■



GTG, Mandrels for quick-change abrasive discs

Ordering example: A33500200026

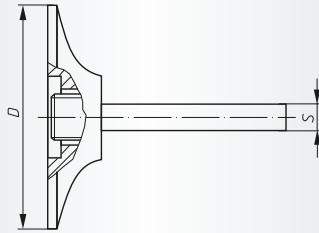
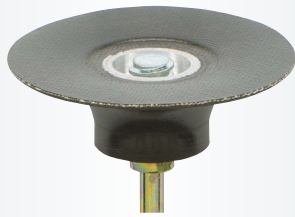

Packing unit:

1 pc. per type

n max.: please also refer to Abrasive discs, PSG, page 334–338

Description	D mm	S mm	Type	n max. (1/min)	Product-Number																		
GTG 020.06	18	6	medium	40.000	A33500200026																	■	
GTG 025.06	23	6	medium	40.000	A33500250026																		■
GTG 038.06	33	6	medium	25.000	A33500380026																		■
GTG 050.06	45	6	medium	25.000	A33500500026																		■
GTG 050.06	45	6	hard	30.000	A33500500036																		■
GTG 075.06	70	6	medium	20.000	A33500750026																		■
GTG 075.06	70	6	hard	20.000	A33500750036																		■

The mandrels are supplied in a **medium** hardness for universal application. For severe applications (when using Z POWER and CERAMIC) please use **hard** quality mandrels.

The stated maximum operating speed is calculated using the maximum mandrel diameter and maximum overhang L_0 of 5 mm. For other overhangs and smaller mandrel diameters, the maximum operating speed must be re-calculated.

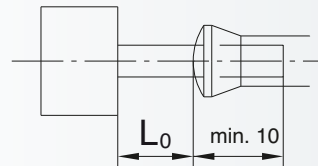

PSR, Qualities and Applications

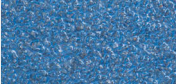
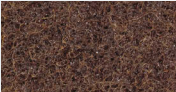
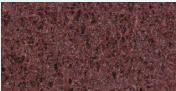
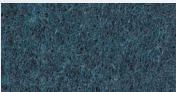
Quality	Characteristics	Applications/Grinding	Page
 <p>Abrasive cloth with Zirconia Alum. Oxide</p> <p>ZK</p>	<p>very tough and resilient grain</p>	<p>Ideal for hastelloy, inconel, stainless and steels difficult to machine.</p>	<p>341</p>
 <p>Fleece Reg. Aluminium oxide coarse/brown</p>  <p>medium/red-brown</p>  <p>fine/blue</p>	<p>Polishing effect through the fibre structure, constant working results due to steadily discharge of abrasive particles. Outstanding tool life.</p>	<p>Ideal for removing rust or paint, scratches and pre-machining marks. A general improvement of the surface finish.</p>	<p>341</p>



Industry

PSR, Abrasive discs with plastic thread, quick-change

Ordering example: A3363038060

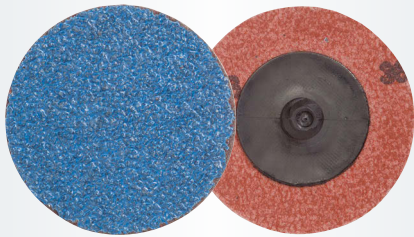
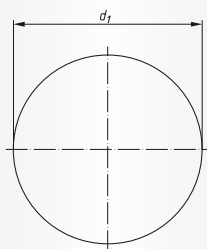
				<p>Packing unit: 100 pcs. per type</p>			
Description	Quality Grits	d ₁ mm	n max. (1/min)	Suitable carriers	Product-Number	recommended for	
PSR 038	ZK 60	38	30.000	GTR 038	A3363038060	1 2 3 4 5 7	■
PSR 038	ZK 80	38	30.000	GTR 038	A3363038080	1 2 3 4 5 7	■
PSR 050	ZK 36	51	30.000	GTR 038 and GTR 050	A3363050036	1 2 3 4 5 7	■
PSR 050	ZK 60	51	30.000	GTR 038 and GTR 050	A3363050060	1 2 3 4 5 7	■
PSR 050	ZK 80	51	30.000	GTR 038 and GTR 050	A3363050080	1 2 3 4 5 7	■
PSR 075	ZK 36	76	20.000	GTR 075	A3363075036	1 2 3 4 5 7	■
PSR 075	ZK 60	76	20.000	GTR 075	A3363075060	1 2 3 4 5 7	■
PSR 075	ZK 80	76	20.000	GTR 075	A3363075080	1 2 3 4 5 7	■



Industry

PSR, Abrasive discs with plastic thread, quick-change heavy duty fleece

Ordering example: A3375038005

				<p>Packing unit: 50 pcs. per type from Ø 75 mm: 25 pcs. per type</p>			
Description	Quality Grits	d ₁ mm	n max. (1/min)	Suitable carriers	Product-Number	recommended for	
PSR 038	Fleece fine	38	10.000	GTR 038	A3375038005	1 2 3 4 5 6 7 8	■
PSR 038	Fleece medium	38	10.000	GTR 038	A3375038002	1 2 3 4 5 6 7 8	■
PSR 050	Fleece coarse	51	8.000	GTR 038 and GTR 050	A3375050004	1 2 3 4 5 6 7 8	■
PSR 050	Fleece fine	51	8.000	GTR 038 and GTR 050	A3375050005	1 2 3 4 5 6 7 8	■
PSR 050	Fleece medium	51	8.000	GTR 038 and GTR 050	A3375050002	1 2 3 4 5 6 7 8	■
PSR 075	Fleece coarse	76	5.500	GTR 038, GTR 050 and GTR 075	A3375075004	1 2 3 4 5 6 7 8	■
PSR 075	Fleece fine	76	5.500	GTR 038, GTR 050 and GTR 075	A3375075005	1 2 3 4 5 6 7 8	■
PSR 075	Fleece medium	76	5.500	GTR 038, GTR 050 and GTR 075	A3375075002	1 2 3 4 5 6 7 8	■



SLTG, Flap Disc, quick-change type

Ordering example: A33310500401623

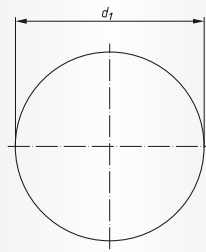

Packing unit:

10 pcs. per type

v_{max} : 50 m/s

ZK = Zirconia Alum. Oxide

Description	Grits	d ₁ mm	n max. (1/min)	Suitable carriers	Product-Number	recommended for									
SLTG 050 R	ZK 40	50	19.000	GTR 038.06	A33310500401623	1	2	3	4	5		7			■
SLTG 050 R	ZK 60	50	19.000	GTR 038.06	A33310500601623	1	2	3	4	5		7			■
SLTG 050 R	ZK 80	50	19.000	GTR 038.06	A33310500801623	1	2	3	4	5		7			■
SLTG 050 R	ZK 120	50	19.000	GTR 038.06	A33310501201623	1	2	3	4	5		7			■
SLTG 065 R	ZK 40	65	14.700	GTR 050.06	A33310650401623	1	2	3	4	5		7			■
SLTG 065 R	ZK 60	65	14.700	GTR 050.06	A33310650601623	1	2	3	4	5		7			■
SLTG 065 R	ZK 80	65	14.700	GTR 050.06	A33310650801623	1	2	3	4	5		7			■
SLTG 075 R	ZK 40	75	12.700	GTR 050.06	A33310750401623	1	2	3	4	5		7			■
SLTG 075 R	ZK 60	75	12.700	GTR 050.06	A33310750601623	1	2	3	4	5		7			■
SLTG 075 R	ZK 80	75	12.700	GTR 050.06	A33310750801623	1	2	3	4	5		7			■
SLTG 075 R	ZK 120	75	12.700	GTR 050.06	A33310751201623	1	2	3	4	5		7			■

Properties

- excellent cutting action
- aggressive, even with minimum grinding pressure
- long tool life (compared to fibre discs)
- lamellar projection
- flexible

Application:

- deburring
- fettling
- rust removal
- finishing
- cleaning of weld seams



GTR, Mandrels for quick-change abrasive discs and SLTG with plastic thread

Ordering example: A33600380026

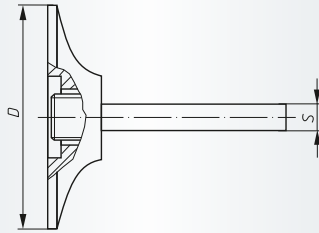

Packing unit:

1 pc. per type

n max.: please also refer to Abrasive discs, PSR, page 341 and flap disc SLTG, page 342

Description	D mm	S mm	Type	n max. (1/min)	Product-Number															
GTR 038.06	33	6	medium	25.000	A33600380026															■
GTR 050.06	45	6	medium	25.000	A33600500026															■
GTR 075.06	70	6	medium	20.000	A33600750026															■

The mandrels are supplied with a hardness for universal application; our **medium** type is suitable for nearly all applications.

Depending on the ordered quantities, other hardnesses are available on request.

The stated maximum operating speed is calculated using the maximum mandrel diameter and maximum overhang L_0 of 5 mm.

For other overhangs and smaller mandrel diameters, the maximum operating speed must be re-calculated.

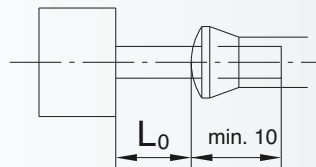



PSK, Abrasive discs, self-adhesive, Silicon carbide

Ordering example: A2305018080

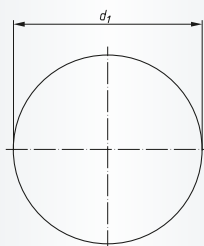
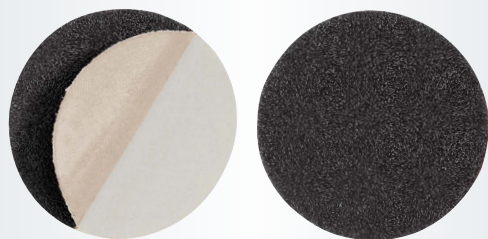

Packing unit:

100 pcs. per type

n max.: please refer to the mandrels self-adhesive
GTK, page 345

SIC = Silicon carbide

Description	Grits	d ₁ mm	Product-Number	recommended for	
PSK 018	SIC 80	21	A2305018080	① ② ③ ④ ⑤ ⑥ ⑦ ⑧ ⑨	■
PSK 018	SIC 120	21	A2305018120	① ② ③ ④ ⑤ ⑥ ⑦ ⑧ ⑨	■
PSK 030	SIC 60	33	A2305030060	① ② ③ ④ ⑤ ⑥ ⑦ ⑧ ⑨	■
PSK 030	SIC 80	33	A2305030080	① ② ③ ④ ⑤ ⑥ ⑦ ⑧ ⑨	■
PSK 030	SIC 120	33	A2305030120	① ② ③ ④ ⑤ ⑥ ⑦ ⑧ ⑨	■
PSK 045	SIC 60	48	A2305045060	① ② ③ ④ ⑤ ⑥ ⑦ ⑧ ⑨	■
PSK 045	SIC 80	48	A2305045080	① ② ③ ④ ⑤ ⑥ ⑦ ⑧ ⑨	■
PSK 045	SIC 120	48	A2305045120	① ② ③ ④ ⑤ ⑥ ⑦ ⑧ ⑨	■



PSK, Abrasive discs, self-adhesive, reg. Aluminium Oxide

Ordering example: A2300018060

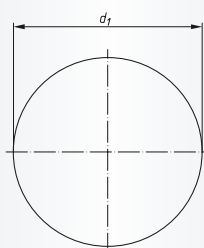

Packing unit:

100 pcs. per type

n max.: please refer to the mandrels self-adhesive
GTK, page 345

NK = reg. Aluminium Oxide

Description	Grits	d ₁ mm	Product-Number	recommended for	
PSK 018	NK 60	21	A2300018060	① ② ③ ④ ⑤ ⑥ ⑦ ⑧	■
PSK 018	NK 80	21	A2300018080	① ② ③ ④ ⑤ ⑥ ⑦ ⑧	■
PSK 018	NK 120	21	A2300018120	① ② ③ ④ ⑤ ⑥ ⑦ ⑧	■
PSK 018	NK 150	21	A2300018150	① ② ③ ④ ⑤ ⑥ ⑦ ⑧	■
PSK 018	NK 180	21	A2300018180	① ② ③ ④ ⑤ ⑥ ⑦ ⑧	■
PSK 018	NK 240	21	A2300018240	① ② ③ ④ ⑤ ⑥ ⑦ ⑧	■
PSK 030	NK 60	33	A2300030060	① ② ③ ④ ⑤ ⑥ ⑦ ⑧	■
PSK 030	NK 80	33	A2300030080	① ② ③ ④ ⑤ ⑥ ⑦ ⑧	■
PSK 030	NK 120	33	A2300030120	① ② ③ ④ ⑤ ⑥ ⑦ ⑧	■
PSK 030	NK 150	33	A2300030150	① ② ③ ④ ⑤ ⑥ ⑦ ⑧	■
PSK 030	NK 180	33	A2300030180	① ② ③ ④ ⑤ ⑥ ⑦ ⑧	■
PSK 030	NK 240	33	A2300030240	① ② ③ ④ ⑤ ⑥ ⑦ ⑧	■
PSK 045	NK 60	48	A2300045060	① ② ③ ④ ⑤ ⑥ ⑦ ⑧	■
PSK 045	NK 80	48	A2300045080	① ② ③ ④ ⑤ ⑥ ⑦ ⑧	■
PSK 045	NK 120	48	A2300045120	① ② ③ ④ ⑤ ⑥ ⑦ ⑧	■
PSK 045	NK 150	48	A2300045150	① ② ③ ④ ⑤ ⑥ ⑦ ⑧	■



Industry

PSK, Abrasive discs, self-adhesive, reg. Aluminium Oxide

Ordering example: A2300045180

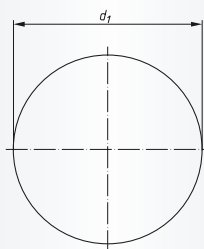
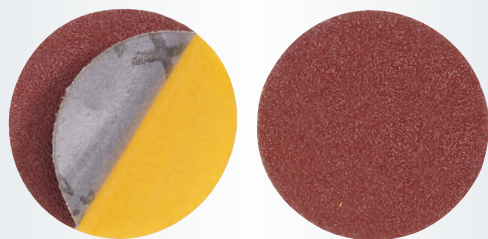

Packing unit:

100 pcs. per type

n max.: please refer to the mandrels self-adhesive
GTK, page 345

NK = reg. Aluminium Oxide

Description	Grits	d ₁ mm	Product-Number	recommended for	
PSK 045	NK 180	48	A2300045180	① ② ③ ④ ⑤ ⑥ ⑦ ⑧	■
PSK 045	NK 240	48	A2300045240	① ② ③ ④ ⑤ ⑥ ⑦ ⑧	■
PSK 060	NK 60	63	A2300060060	① ② ③ ④ ⑤ ⑥ ⑦ ⑧	■
PSK 060	NK 80	63	A2300060080	① ② ③ ④ ⑤ ⑥ ⑦ ⑧	■
PSK 060	NK 120	63	A2300060120	① ② ③ ④ ⑤ ⑥ ⑦ ⑧	■
PSK 060	NK 150	63	A2300060150	① ② ③ ④ ⑤ ⑥ ⑦ ⑧	■
PSK 075	NK 60	78	A2300075060	① ② ③ ④ ⑤ ⑥ ⑦ ⑧	■
PSK 075	NK 80	78	A2300075080	① ② ③ ④ ⑤ ⑥ ⑦ ⑧	■
PSK 075	NK 120	78	A2300075120	① ② ③ ④ ⑤ ⑥ ⑦ ⑧	■
PSK 075	NK 150	78	A2300075150	① ② ③ ④ ⑤ ⑥ ⑦ ⑧	■



Industry

GTK, Mandrels, for self-adhesive abrasive discs

Ordering example: A250301830001

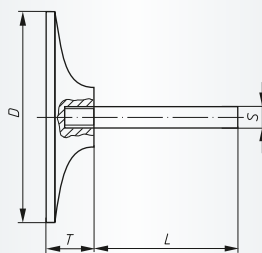

Packing unit:

5 pcs. per type,

from Ø 75 mm = 2 pcs. per type

Description	D mm	S mm	T mm	L mm	n max. (1/min)	Product-Number		
GTK 018.03	18	3	11	30	20.000	A250301830001		■
GTK 030.03	30	3	12	30	12.500	A250303030001		■
GTK 030.06	30	6	12	40	12.500	A250303060001		■
GTK 045.06	45	6	11	40	10.000	A250304560001		■
GTK 060.06	60	6	13	40	8.000	A250306060001		■
GTK 075.06	75	6	15	40	6.000	A250307560001		■

The stated maximum operating speed only applies to a maximum overhang L_0 of 20 mm. Other overhang dimensions must be calculated separately.

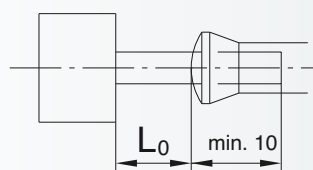



PSH, Abrasive discs, self-adhesive, Diamond

Ordering example: A3301050126

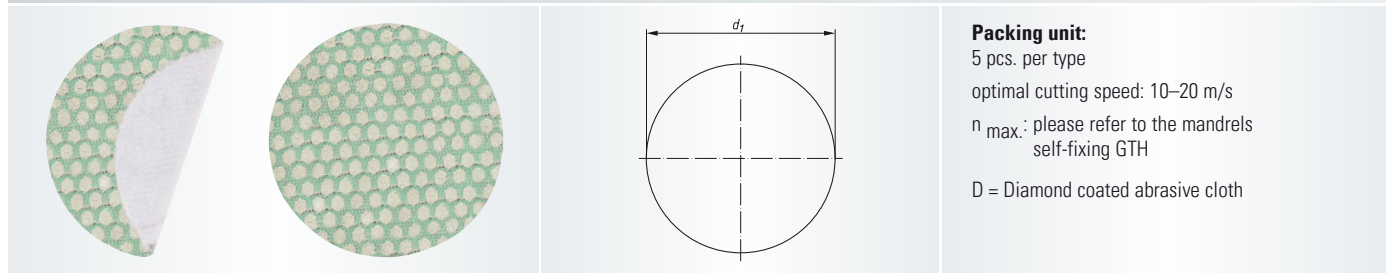

Packing unit:
 5 pcs. per type
 optimal cutting speed: 10–20 m/s
 n_{max} : please refer to the mandrels
 self-fixing GTH
 D = Diamond coated abrasive cloth

Description	Grits	d ₁ mm	Product-Number	recommended for
PSH 050	D126	50	A3301050126	7 8 9 ■
PSH 075	D126	75	A3301075126	7 8 9 ■

Diamond abrasive discs are perfect for dealing with hard layers, such as wear protection coatings or armouring made from tungsten, chromium or titanium carbide.

They are also great for other hard materials like glass, ceramic, stone, enamel, carbide or abrasive composite materials from glass or carbon fibre reinforced plastic. Another application is for materials used for turbines and power trains, e.g., hastelloy, inconel and titanium alloys.



GTH, Mandrels, for self-fixing abrasive discs

Ordering example: A250401830001

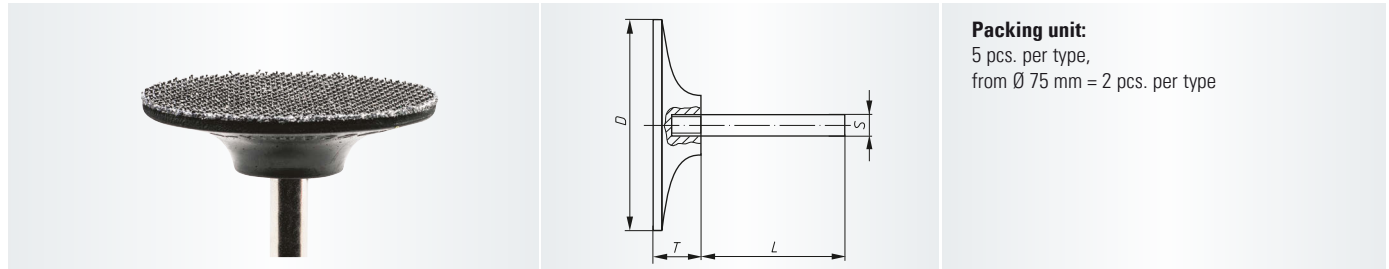

Packing unit:
 5 pcs. per type,
 from Ø 75 mm = 2 pcs. per type

Description	D mm	S mm	T mm	L mm	n max. (1/min)	Product-Number	recommended for
GTH 018.03	18	3	11	30	20.000	A250401830001	■
GTH 030.03	30	3	12	30	12.500	A250403030001	■
GTH 030.06	30	6	12	40	12.500	A250403060001	■
GTH 045.06	45	6	11	40	10.000	A250404560001	■
GTH 060.06	60	6	13	40	8.000	A250406060001	■
GTH 075.06	75	6	15	40	6.000	A250407560001	■
GTH 120.06	120	6	20	25	4.000	A25041206	■
GTH 120.08	120	8	20	25	4.000	A25041208	■

The stated maximum operating speed only applies to a maximum overhang L_0 of 20 mm. Other overhang dimensions must be calculated separately.

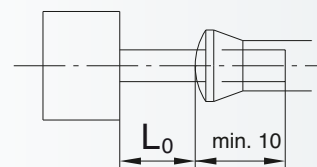



PSH, Abrasive discs, self-fixing

Ordering example: A3300018060

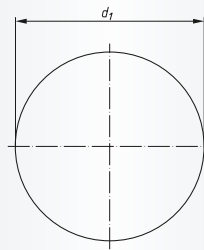

Packing unit:

100 pcs. per type

n max.: please refer to the mandrels self-fixing GTH, page 346

NK = reg. Aluminium Oxide

Description	Grits	d ₁ mm	Product-Number	recommended for	
PSH 018	NK 60	20	A3300018060	① ② ③ ④ ⑤ ⑥ ⑦ ⑧	■
PSH 018	NK 80	20	A3300018080	① ② ③ ④ ⑤ ⑥ ⑦ ⑧	■
PSH 018	NK 120	20	A3300018120	① ② ③ ④ ⑤ ⑥ ⑦ ⑧	■
PSH 018	NK 150	20	A3300018150	① ② ③ ④ ⑤ ⑥ ⑦ ⑧	■
PSH 018	NK 180	20	A3300018180	① ② ③ ④ ⑤ ⑥ ⑦ ⑧	■
PSH 018	NK 240	20	A3300018240	① ② ③ ④ ⑤ ⑥ ⑦ ⑧	■
PSH 018	NK 320	20	A3300018320	① ② ③ ④ ⑤ ⑥ ⑦ ⑧	■
PSH 030	NK 60	33	A3300030060	① ② ③ ④ ⑤ ⑥ ⑦ ⑧	■
PSH 030	NK 80	33	A3300030080	① ② ③ ④ ⑤ ⑥ ⑦ ⑧	■
PSH 030	NK 120	33	A3300030120	① ② ③ ④ ⑤ ⑥ ⑦ ⑧	■
PSH 030	NK 150	33	A3300030150	① ② ③ ④ ⑤ ⑥ ⑦ ⑧	■
PSH 030	NK 180	33	A3300030180	① ② ③ ④ ⑤ ⑥ ⑦ ⑧	■
PSH 030	NK 240	33	A3300030240	① ② ③ ④ ⑤ ⑥ ⑦ ⑧	■
PSH 030	NK 320	33	A3300030320	① ② ③ ④ ⑤ ⑥ ⑦ ⑧	■
PSH 045	NK 60	48	A3300045060	① ② ③ ④ ⑤ ⑥ ⑦ ⑧	■
PSH 045	NK 80	48	A3300045080	① ② ③ ④ ⑤ ⑥ ⑦ ⑧	■
PSH 045	NK 120	48	A3300045120	① ② ③ ④ ⑤ ⑥ ⑦ ⑧	■
PSH 045	NK 150	48	A3300045150	① ② ③ ④ ⑤ ⑥ ⑦ ⑧	■
PSH 045	NK 180	48	A3300045180	① ② ③ ④ ⑤ ⑥ ⑦ ⑧	■
PSH 045	NK 240	48	A3300045240	① ② ③ ④ ⑤ ⑥ ⑦ ⑧	■
PSH 060	NK 60	63	A3300060060	① ② ③ ④ ⑤ ⑥ ⑦ ⑧	■
PSH 060	NK 80	63	A3300060080	① ② ③ ④ ⑤ ⑥ ⑦ ⑧	■
PSH 060	NK 120	63	A3300060120	① ② ③ ④ ⑤ ⑥ ⑦ ⑧	■
PSH 060	NK 150	63	A3300060150	① ② ③ ④ ⑤ ⑥ ⑦ ⑧	■
PSH 060	NK 180	63	A3300060180	① ② ③ ④ ⑤ ⑥ ⑦ ⑧	■
PSH 060	NK 240	63	A3300060240	① ② ③ ④ ⑤ ⑥ ⑦ ⑧	■
PSH 060	NK 320	63	A3300060320	① ② ③ ④ ⑤ ⑥ ⑦ ⑧	■
PSH 075	NK 60	78	A3300075060	① ② ③ ④ ⑤ ⑥ ⑦ ⑧	■
PSH 075	NK 80	78	A3300075080	① ② ③ ④ ⑤ ⑥ ⑦ ⑧	■
PSH 075	NK 120	78	A3300075120	① ② ③ ④ ⑤ ⑥ ⑦ ⑧	■
PSH 075	NK 150	78	A3300075150	① ② ③ ④ ⑤ ⑥ ⑦ ⑧	■
PSH 075	NK 180	78	A3300075180	① ② ③ ④ ⑤ ⑥ ⑦ ⑧	■
PSH 075	NK 240	78	A3300075240	① ② ③ ④ ⑤ ⑥ ⑦ ⑧	■
PSH 075	NK 320	78	A3300075320	① ② ③ ④ ⑤ ⑥ ⑦ ⑧	■
PSH 125	NK 60	125	A3300120060	① ② ③ ④ ⑤ ⑥ ⑦ ⑧	■
PSH 125	NK 80	125	A3300120080	① ② ③ ④ ⑤ ⑥ ⑦ ⑧	■

348 Abrasive discs, self-fixing and Mandrels, for self-fixing abrasive discs



Industry

PSH, Quick-change abrasive discs with non-woven material, Velcro self fixing system *Ordering example: A3380115102*

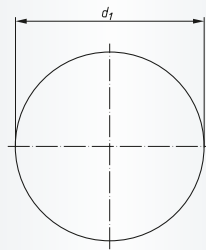
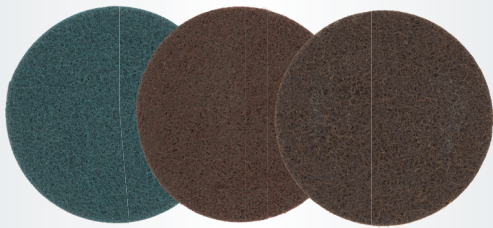

Packing unit:
10 pcs. per type

Description	Grits	d ₁ mm	n recom. (1/min)	n max. (1/min)	Product-Number	recommended for	
PSH 115	Fleece coarse	115	4.000	8.000	A3380115102	① ② ③ ④ ⑤ ⑥ ⑦ ⑧	■
PSH 115	Fleece medium	115	4.000	8.000	A3380115104	① ② ③ ④ ⑤ ⑥ ⑦ ⑧	■
PSH 115	Fleece fine	115	4.000	8.000	A3380115107	① ② ③ ④ ⑤ ⑥ ⑦ ⑧	■
PSH 125	Fleece coarse	125	3.800	7.650	A3380125102	① ② ③ ④ ⑤ ⑥ ⑦ ⑧	■
PSH 125	Fleece medium	125	3.800	7.650	A3380125104	① ② ③ ④ ⑤ ⑥ ⑦ ⑧	■
PSH 125	Fleece fine	125	4.800	7.650	A3380125107	① ② ③ ④ ⑤ ⑥ ⑦ ⑧	■



Industry

GTH, Mandrels for abrasive discs with non-woven material *Ordering example: A38311151003*

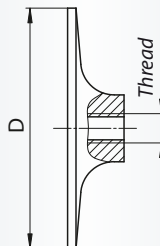

Packing unit:
1 pc. per type

Description	D mm	Thread	n max. (1/min)	Product-Number		
GTH 115	115	M14	8.000	A38311151003		■
GTH 125	125	M14	7.650	A38311251003		■

Fibre discs, backing plates, economy rolls, abrasive sheets and fleece rolls

228 Qualities and Applications

350 General Information

351 FIS, Fibre Discs with slotted hole

354 Semi-flexible grinding disc

355 STF, Fibre Disc Backing Pad

356 Economy rolls

357 SLB, sheets of abrasive cloth

358 Fleece pads

358 Fleece rolls

Product line marking

Product lines are labelled in the table header with the appropriate tabs. Further information on page **14** and **15**.

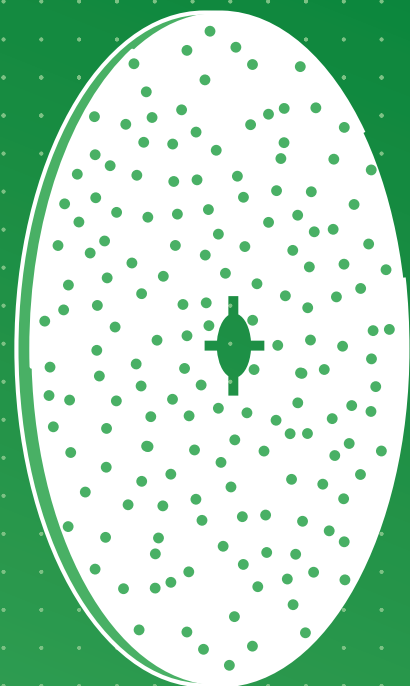

Information

FIS, Fibre Discs

Fibre-backed discs FIS are used on angle grinders with a backing pad STF. We offer this very popular product in NK, ZK and Ceramic for universal application.

SHF semi-flexible grinding disc

The SHF semi-flexible grinding disc consists of a stable fibre backing with a structured abrasive coating of silicon carbide. This combination is particularly suitable for coarse grinding work on the biggest variety of materials. Typical applications are the removal of paint, rust and adhesives, but also the processing of glass-fibre reinforced plastics such as GRP and CRP (e.g. during the manufacture of wind turbine blades). Like fibre discs, semi-flexible grinding discs for angle grinders are only used with an STF backing plate.

SPR, Economy rolls

We supply economy rolls manufactured from flexible coated abrasive for off-hand application. The appropriate length can be cut from the roll.

SVB, Fleece pads and SVR, Fleece rolls

We supply abrasive fleece economy rolls and pads used off-hand or on vibratory finishing machines. These can be used wet or dry.



High Performance

FIS, Fibre Disc with slotted hole, Ceramic grain

Ordering example: A38301150243

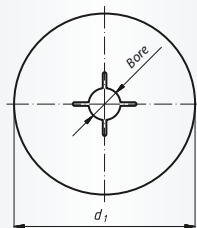

Packing unit:
50 pcs. per type
 v_{max} : 80 m/s
ISO 16057
Ceramic = ceramic grain

Description	Grits	d ₁ mm	Bore mm	n max. (1/min)	Product-Number	recommended for	
FIS 115	Ceramic 24	115	22	13.000	A38301150243	1 2 3 4 5 6 7	■
FIS 115	Ceramic 36	115	22	13.000	A38301150363	1 2 3 4 5 6 7	■
FIS 115	Ceramic 60	115	22	13.000	A38301150603	1 2 3 4 5 6 7	■
FIS 115	Ceramic 80	115	22	13.000	A38301150803	1 2 3 4 5 6 7	■
FIS 125	Ceramic 24	125	22	12.000	A38301250243	1 2 3 4 5 6 7	■
FIS 125	Ceramic 36	125	22	12.000	A38301250363	1 2 3 4 5 6 7	■
FIS 125	Ceramic 60	125	22	12.000	A38301250603	1 2 3 4 5 6 7	■
FIS 125	Ceramic 80	125	22	12.000	A38301250803	1 2 3 4 5 6 7	■
FIS 180	Ceramic 24	180	22	8.500	A38301800243	1 2 3 4 5 6 7	■
FIS 180	Ceramic 36	180	22	8.500	A38301800363	1 2 3 4 5 6 7	■



Industry

FIS, Fibre Disc with slotted hole, Zirconia Alum. Oxide

Ordering example: A38301150242

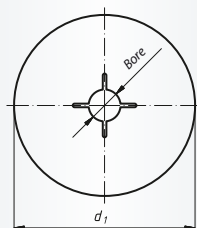

Packing unit:
50 pcs. per type
 v_{max} : 80 m/s
ISO 16057
ZK = Zirconia Alum. Oxide

Description	Grits	d ₁ mm	Bore mm	n max. (1/min)	Product-Number	recommended for	
FIS 115	ZK 24	115	22	13.000	A38301150242	2 3 4 5 7	■
FIS 115	ZK 36	115	22	13.000	A38301150362	2 3 4 5 7	■
FIS 115	ZK 40	115	22	13.000	A38301150402	2 3 4 5 7	■
FIS 115	ZK 60	115	22	13.000	A38301150602	2 3 4 5 7	■
FIS 115	ZK 80	115	22	13.000	A38301150802	2 3 4 5 7	■
FIS 125	ZK 24	125	22	12.000	A38301250242	2 3 4 5 7	■
FIS 125	ZK 36	125	22	12.000	A38301250362	2 3 4 5 7	■
FIS 125	ZK 40	125	22	12.000	A38301250402	2 3 4 5 7	■
FIS 125	ZK 60	125	22	12.000	A38301250602	2 3 4 5 7	■
FIS 125	ZK 80	125	22	12.000	A38301250802	2 3 4 5 7	■



FIS, Fibre Disc with slotted hole, reg. Aluminium Oxide

Ordering example: A38301150241

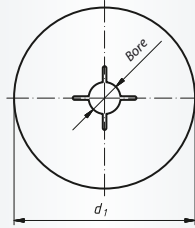

Packing unit:

50 pcs. per type

v_{max} : 80 m/s

ISO 16057

NK = reg. Aluminium Oxide

Description	Grits	d ₁ mm	Bore mm	n max. (1/min)	Product-Number	recommended for	
FIS 115	NK 24	115	22	13.000	A38301150241	① ② ③ ④ ⑤ ⑥ ⑦ ⑧	■
FIS 115	NK 36	115	22	13.000	A38301150361	① ② ③ ④ ⑤ ⑥ ⑦ ⑧	■
FIS 115	NK 40	115	22	13.000	A38301150401	① ② ③ ④ ⑤ ⑥ ⑦ ⑧	■
FIS 115	NK 50	115	22	13.000	A38301150501	① ② ③ ④ ⑤ ⑥ ⑦ ⑧	■
FIS 115	NK 60	115	22	13.000	A38301150601	① ② ③ ④ ⑤ ⑥ ⑦ ⑧	■
FIS 115	NK 80	115	22	13.000	A38301150801	① ② ③ ④ ⑤ ⑥ ⑦ ⑧	■
FIS 115	NK 120	115	22	13.000	A38301151201	① ② ③ ④ ⑤ ⑥ ⑦ ⑧	■
FIS 125	NK 24	125	22	12.000	A38301250241	① ② ③ ④ ⑤ ⑥ ⑦ ⑧	■
FIS 125	NK 36	125	22	12.000	A38301250361	① ② ③ ④ ⑤ ⑥ ⑦ ⑧	■
FIS 125	NK 40	125	22	12.000	A38301250401	① ② ③ ④ ⑤ ⑥ ⑦ ⑧	■
FIS 125	NK 50	125	22	12.000	A38301250501	① ② ③ ④ ⑤ ⑥ ⑦ ⑧	■
FIS 125	NK 60	125	22	12.000	A38301250601	① ② ③ ④ ⑤ ⑥ ⑦ ⑧	■
FIS 125	NK 80	125	22	12.000	A38301250801	① ② ③ ④ ⑤ ⑥ ⑦ ⑧	■
FIS 150	NK 40	150	22	10.000	A38301500401	① ② ③ ④ ⑤ ⑥ ⑦ ⑧	■
FIS 150	NK 60	150	22	10.000	A38301500601	① ② ③ ④ ⑤ ⑥ ⑦ ⑧	■
FIS 180	NK 16	180	22	8.500	A38301800161	① ② ③ ④ ⑤ ⑥ ⑦ ⑧	■
FIS 180	NK 24	180	22	8.500	A38301800241	① ② ③ ④ ⑤ ⑥ ⑦ ⑧	■
FIS 180	NK 36	180	22	8.500	A38301800361	① ② ③ ④ ⑤ ⑥ ⑦ ⑧	■
FIS 180	NK 40	180	22	8.500	A38301800401	① ② ③ ④ ⑤ ⑥ ⑦ ⑧	■
FIS 180	NK 60	180	22	8.500	A38301800601	① ② ③ ④ ⑤ ⑥ ⑦ ⑧	■
FIS 180	NK 80	180	22	8.500	A38301800801	① ② ③ ④ ⑤ ⑥ ⑦ ⑧	■



Base

FIS BASE-X, Fibre Disc with slotted hole, reg. Aluminium Oxide

Ordering example: A7830115024101

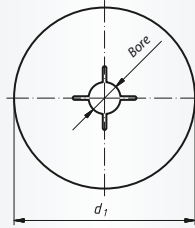

Packing unit:

25 pcs. per type

v_{max} : 80 m/s

ISO 16057

NK = reg. Aluminium Oxide

Description	Grits	d ₁ mm	Bore mm	n max. (1/min)	Product-Number	recommended for	
FIS 115 BASE-X	NK 24	115	22	13.000	A7830115024101	① ② ③ ④ ⑤ ⑥ ⑦ ⑧	■
FIS 115 BASE-X	NK 36	115	22	13.000	A7830115036101	① ② ③ ④ ⑤ ⑥ ⑦ ⑧	■
FIS 115 BASE-X	NK 40	115	22	13.000	A7830115040101	① ② ③ ④ ⑤ ⑥ ⑦ ⑧	■
FIS 115 BASE-X	NK 60	115	22	13.000	A7830115060101	① ② ③ ④ ⑤ ⑥ ⑦ ⑧	■
FIS 115 BASE-X	NK 80	115	22	13.000	A7830115080101	① ② ③ ④ ⑤ ⑥ ⑦ ⑧	■
FIS 115 BASE-X	NK 120	115	22	13.000	A7830115120101	① ② ③ ④ ⑤ ⑥ ⑦ ⑧	■
FIS 125 BASE-X	NK 24	125	22	12.000	A7830125024101	① ② ③ ④ ⑤ ⑥ ⑦ ⑧	■
FIS 125 BASE-X	NK 36	125	22	12.000	A7830125036101	① ② ③ ④ ⑤ ⑥ ⑦ ⑧	■
FIS 125 BASE-X	NK 40	125	22	12.000	A7830125040101	① ② ③ ④ ⑤ ⑥ ⑦ ⑧	■
FIS 125 BASE-X	NK 60	125	22	12.000	A7830125060101	① ② ③ ④ ⑤ ⑥ ⑦ ⑧	■
FIS 125 BASE-X	NK 80	125	22	12.000	A7830125080101	① ② ③ ④ ⑤ ⑥ ⑦ ⑧	■
FIS 125 BASE-X	NK 120	125	22	12.000	A7830125120101	① ② ③ ④ ⑤ ⑥ ⑦ ⑧	■
FIS 180 BASE-X	NK 24	180	22	8.500	A7830180024101	① ② ③ ④ ⑤ ⑥ ⑦ ⑧	■
FIS 180 BASE-X	NK 36	180	22	8.500	A7830180036101	① ② ③ ④ ⑤ ⑥ ⑦ ⑧	■
FIS 180 BASE-X	NK 40	180	22	8.500	A7830180040101	① ② ③ ④ ⑤ ⑥ ⑦ ⑧	■
FIS 180 BASE-X	NK 60	180	22	8.500	A7830180060101	① ② ③ ④ ⑤ ⑥ ⑦ ⑧	■
FIS 180 BASE-X	NK 80	180	22	8.500	A7830180080101	① ② ③ ④ ⑤ ⑥ ⑦ ⑧	■



SHF semi-flexible grinding disc

Ordering example: A38351150164

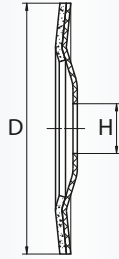

Packing unit:
25 pcs. per type
C = Silicon carbide

Description	Grits	D mm	H mm	n max. (1/min)	Product-Number	recommended for	
SHF 115	C16	115	22,23	13.300	A38351150164	1 2 5 6 8 10	■
SHF 115	C24	115	22,23	13.300	A38351150244	1 2 5 6 8 10	■
SHF 115	C36	115	22,23	13.300	A38351150364	1 2 5 6 8 10	■
SHF 115	C60	115	22,23	13.300	A38351150604	1 2 5 6 8 10	■
SHF 125	C24	125	22,23	12.200	A38351250244	1 2 5 6 8 10	■
SHF 125	C36	125	22,23	12.200	A38351250364	1 2 5 6 8 10	■

Use only with backing plate.



High Performance

STF HL, Backing-Pad with cooling ribs for Fibre Discs

Ordering example: A38311151002

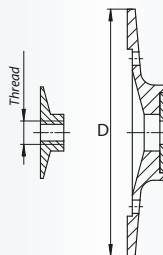

Packing unit:
1 pc. per type

Description	D mm	Thread	n max. (1/min)	Product-Number															
STF HL 115	113	M 14	13.300	A38311151002															■
STF HL 125	123	M 14	12.200	A38311251002															■
STF HL 150	148	M 14	10.200	A38311501002															■
STF HL 180	175	M 14	8.500	A38311801002															■

The mandrels are supplied in a hardness for universal tasks, and our medium design is suitable for practically every application. Our designs for radii and rough grinding work can be delivered on request. Cooling ribs and ventilation holes increase the stock removal rate and service life of mounted tools.



Industry

STF, Fibre Disc Backing-Pad with threaded flange

Ordering example: A38311151001

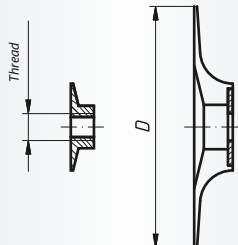

Packing unit:
1 pc. per type

Description	D mm	Thread	n max. (1/min)	Product-Number															
STF 115	113	M 14	13.000	A38311151001															■
STF 125	123	M 14	12.000	A38311251001															■
STF 150	148	M 14	10.000	A38311501001															■
STF 180	175	M 14	8.500	A38311701001															■

The Backing-Pads are supplied with different hardnesses for universal application; the medium hardness is suitable for nearly all applications. Other hardnesses are available for snagging and profiling operations.



SPR, Economy Rolls, reg. Aluminium Oxide

Ordering example: A3821025040

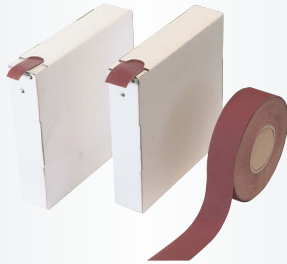

Packing unit:

1 pc. per type

NK = reg. Aluminium Oxide

Description	Grits	wide mm	long m	Product-Number	recommended for	
SPR 025	NK 40	25	50	A3821025040	① ② ③ ④ ⑤ ⑥ ⑦ ⑧	■
SPR 025	NK 60	25	50	A3821025060	① ② ③ ④ ⑤ ⑥ ⑦ ⑧	■
SPR 025	NK 80	25	50	A3821025080	① ② ③ ④ ⑤ ⑥ ⑦ ⑧	■
SPR 025	NK 100	25	50	A3821025100	① ② ③ ④ ⑤ ⑥ ⑦ ⑧	■
SPR 025	NK 120	25	50	A3821025120	① ② ③ ④ ⑤ ⑥ ⑦ ⑧	■
SPR 025	NK 150	25	50	A3821025150	① ② ③ ④ ⑤ ⑥ ⑦ ⑧	■
SPR 025	NK 180	25	50	A3821025180	① ② ③ ④ ⑤ ⑥ ⑦ ⑧	■
SPR 025	NK 240	25	50	A3821025240	① ② ③ ④ ⑤ ⑥ ⑦ ⑧	■
SPR 025	NK 320	25	50	A3821025320	① ② ③ ④ ⑤ ⑥ ⑦ ⑧	■
SPR 025	NK 400	25	50	A3821025400	① ② ③ ④ ⑤ ⑥ ⑦ ⑧	■
SPR 040	NK 40	40	50	A3821040040	① ② ③ ④ ⑤ ⑥ ⑦ ⑧	■
SPR 040	NK 60	40	50	A3821040060	① ② ③ ④ ⑤ ⑥ ⑦ ⑧	■
SPR 040	NK 80	40	50	A3821040080	① ② ③ ④ ⑤ ⑥ ⑦ ⑧	■
SPR 040	NK 100	40	50	A3821040100	① ② ③ ④ ⑤ ⑥ ⑦ ⑧	■
SPR 040	NK 120	40	50	A3821040120	① ② ③ ④ ⑤ ⑥ ⑦ ⑧	■
SPR 040	NK 150	40	50	A3821040150	① ② ③ ④ ⑤ ⑥ ⑦ ⑧	■
SPR 040	NK 180	40	50	A3821040180	① ② ③ ④ ⑤ ⑥ ⑦ ⑧	■
SPR 040	NK 240	40	50	A3821040240	① ② ③ ④ ⑤ ⑥ ⑦ ⑧	■
SPR 040	NK 320	40	50	A3821040320	① ② ③ ④ ⑤ ⑥ ⑦ ⑧	■
SPR 040	NK 400	40	50	A3821040400	① ② ③ ④ ⑤ ⑥ ⑦ ⑧	■

LUKAS Economy Rolls with their great grinding characteristics help to manage your manual grinding at optimum level.



SLB, Sheets of abrasive cloth

Ordering example: A3825230280040



Packing unit:
50 pcs. per type
NK = reg. Aluminium Oxide

Description	Quality	wide mm	long mm	Product-Number	recommended for	
SLB 230280	NK 40	230	280	A3825230280040	① ② ③ ④ ⑤ ⑥ ⑦ ⑧	■
SLB 230280	NK 60	230	280	A3825230280060	① ② ③ ④ ⑤ ⑥ ⑦ ⑧	■
SLB 230280	NK 80	230	280	A3825230280080	① ② ③ ④ ⑤ ⑥ ⑦ ⑧	■
SLB 230280	NK 100	230	280	A3825230280100	① ② ③ ④ ⑤ ⑥ ⑦ ⑧	■
SLB 230280	NK 120	230	280	A3825230280120	① ② ③ ④ ⑤ ⑥ ⑦ ⑧	■
SLB 230280	NK 150	230	280	A3825230280150	① ② ③ ④ ⑤ ⑥ ⑦ ⑧	■
SLB 230280	NK 180	230	280	A3825230280180	① ② ③ ④ ⑤ ⑥ ⑦ ⑧	■
SLB 230280	NK 220	230	280	A3825230280220	① ② ③ ④ ⑤ ⑥ ⑦ ⑧	■
SLB 230280	NK 240	230	280	A3825230280240	① ② ③ ④ ⑤ ⑥ ⑦ ⑧	■
SLB 230280	NK 320	230	280	A3825230280320	① ② ③ ④ ⑤ ⑥ ⑦ ⑧	■
SLB 230280	NK 400	230	280	A3825230280400	① ② ③ ④ ⑤ ⑥ ⑦ ⑧	■
SLB 230280	NK 999	230	280	A3825230280999	① ② ③ ④ ⑤ ⑥ ⑦ ⑧	■

The LUKAS-sheets of abrasive cloth with optimum abrasive properties will enable you to achieve outstanding results with your manual grinding applications.



SVB, Fleece pads

Ordering example: A380115023011



Packing unit:

50 pcs. per type

A = reg. Aluminium Oxide

C = Silicon carbide

Description	Quality	Type	wide mm	long mm	Product-Number	recommended for	
SVB 150230	A Medium	red-brown	150	210	A380115023011	① ② ③ ④ ⑤ ⑥ ⑦ ⑧	■
SVB 150230	A Fine	green	150	210	A380115023012	① ② ③ ④ ⑤ ⑥ ⑦ ⑧	■
SVB 150230	A Very Fine	red-brown	150	210	A380115023013	① ② ③ ④ ⑤ ⑥ ⑦ ⑧	■
SVB 150230	C Ultra Fine	grey	150	210	A380115023024	① ② ③ ④ ⑤ ⑥ ⑦ ⑧ ⑨	■

LUKAS-fleece pads are used to remove corrosion and stain from metal surfaces as well as to clean and polish surfaces of any kind of material.



SVR, Fleece rolls

Ordering example: A382011501012



Packing unit:

1 pc. per type

A = reg. Aluminium Oxide

C = Silicon carbide

Description	Quality	Type	wide mm	long m	Product-Number	recommended for	
SVR 115	A Fine	green	115	10	A382011501012	① ② ③ ④ ⑤ ⑥ ⑦ ⑧	■
SVR 115	A Very Fine	red-brown	115	10	A382011501013	① ② ③ ④ ⑤ ⑥ ⑦ ⑧	■
SVR 115	C Ultra fine	grey	115	10	A382011501024	① ② ③ ④ ⑤ ⑥ ⑦ ⑧ ⑨	■

LUKAS-fleece rolls are used to remove corrosion and stain from metal surfaces as well as to clean and polish surfaces of any kind of material.

AS-Cleaning fleece

228 Qualities and Applications

360 General Information

361 ASVS, abrasive discs for flexible boring and drilling machines

361 ASB, mounting arbor for ASVS

362 ASVT, for right angle grinders, with reinforced fibre backing



Product line marking

Product lines are labelled in the table header with the appropriate tabs. Further information on page **14** and **15**.



Information

General Information

Our AS surface preparation fleece consists of a coarse Polyamide fleece impregnated with aggressive abrasive grit particles.

Recommendations for use

Products using our AS surface preparation fleece are ideally suited for the following applications:

- removal of paint and adhesives
- removal of cement and concrete residues
- de-rusting, restoring and polishing of a wide variety of surfaces
- graining and the finishing of wood
- de-rusting and preparation work on boats and ships, eg, removing barnacles

- surface preparation of floors and various applications for car-body repair work
- preparation work on welding seams – before and after welding

Safety regulations

Please take care that our recommended cutting speed is not exceeded.

Characteristics

- less generation heat
- “soft” grinding action
- no glazing/loading
- no damage to workpieces

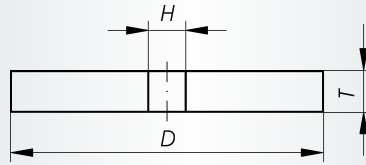
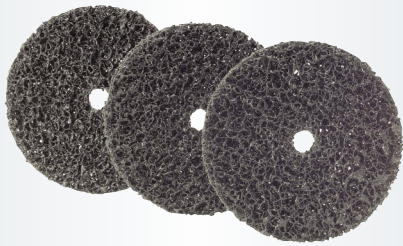
Industry
ASVS, Abrasive discs for flexible boring and drilling machines
Ordering example: A22900601201

Packing unit:
 10 pcs. per type,
 from Ø 150 mm = 5 pcs. per type

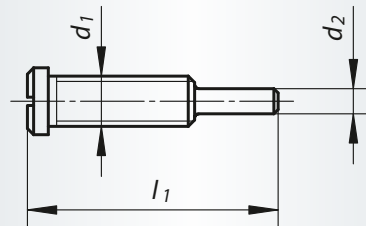
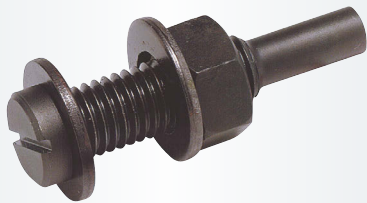
Description	D mm	T mm	H mm	n recom. (1/min)	n max. (1/min)	Retaining bolt	Product-Number	recommended for									
ASVS 060	60	13	13	8.000	9.500	ASB 6	A22900601201	①	②	③	④	⑤	⑥	⑦	⑧	⑨	■
ASVS 100	100	13	13	5.000	5.700	ASB 6	A22901001201	①	②	③	④	⑤	⑥	⑦	⑧	⑨	■
ASVS 125	125	13	13	4.000	4.500	ASB 8	A22901251201	①	②	③	④	⑤	⑥	⑦	⑧	⑨	■
ASVS 150	150	13	13	3.000	3.800	ASB 8	A22901501201	①	②	③	④	⑤	⑥	⑦	⑧	⑨	■

Industry
ASB, Mounting arbor for ASVS, incl. spring washer and nut
Ordering example: A1610021007301

Packing unit:
 1 pc. per type

Description	d ₁ mm	d ₂ mm	l ₁ mm	Product-Number	recommended for												
ASB 06	M12	6	60	A1610021007301													■
ASB 08	M12	8	60	A1610021007302													■

362 AS-Cleaning fleece



Industry

ASVT, for angle grinder, with reinforced fibre backing

Ordering example: A270111500114

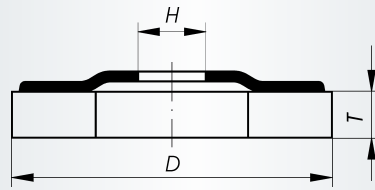

Packing unit:
10 pcs. per type
 v_{max} : 63 m/s

Description	D mm	T mm	H mm	n recom. (1/min)	n max. (1/min)	Product-Number	recommended for	
ASVT 115	115	13	22,3	5.300	10.500	A270111500114	① ② ③ ④ ⑤ ⑥ ⑦ ⑧ ⑨	■
ASVT 125	125	13	22,3	4.900	9.600	A270112500114	① ② ③ ④ ⑤ ⑥ ⑦ ⑧ ⑨	■

Usable without supporting-plate on adjustable and slow-speed angle grinders.

CBN- and diamond tools for precision machining

364 Technical Information

367 CBN/Diamond Grinding Tools, vitrified bonded

373 CBN/Diamond Grinding Tools, electro-plated



Product line marking

Product lines are labelled in the table header with the appropriate tabs. Further information on page **14** and **15**.

Technical information

General

The product group which includes CBN and diamond tools for precision machining is of ever increasing importance in relation to tools consisting of the usual grain types i.e. aluminium oxide and silicon carbide and their further developments e.g. zirconia, mono-crystal and SOL-GEL (SG grain). These super hard grain types include natural and synthetic diamond in „D“ and synthetic cubic boron nitride (CBN) „B“.

Diamond is used for a wide range of hard materials (except steel), eg, carbides, oxides, nitrides and even diamond itself. Various types of plastic and rubber can also be economically machined.

Hardness

The ultrahard grain is considerably more expensive than conventional abrasive. Due to the extreme hardness, greater performance can be achieved when used in conjunction with modern manufacturing techniques; this can produce significant cost reductions.

Micro-Hardness – Temperature stability

The extreme differences in micro-hardness can be identified in the adjoining diagram.

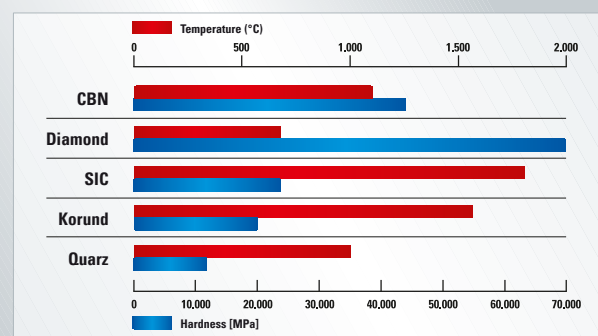

Technical Information

Bond

The following bondings are used in the manufacture of LUKAS CBN and diamond tools:

Vitrified bond

Due to the substantial layer of usable abrasive, vitrified bonded wheels give long tool life. They can be easily dressed and require little grinding pressure. These tools are manufactured in a variety of dimensions and in different structures. They must be used with coolant. A fine surface finish can be achieved.

Electro-Plated

An electro-plated bond provides a low cost tool. Electro-plating allows the manufacture of a large variety of profiles. They can be used wet or dry; coolant improves tool life.

Types of grain

Basically, we must differentiate between mono and polycrystalline types of grain. In the case of diamond, it must also be decided whether to use natural or synthetic types. Many applications require a grain coating of nickel or titanium. The physical and chemical properties, including the shape of individual grit particles,

are the decisive factors when selecting the most suitable grit type. LUKAS vitrified bonded CBN-/diamond tools are identified by a quality code which contains all data determining the specification. The customer also receives this basic information regarding grit size and CBN-/diamond concentration.

Based on ISO 6106 and the corresponding FEPA standard, the grit sizes have been categorized as stated below. Contrary to the grit size classification of conventional grain, cubic-boron nitride and diamond grain are specified based on the following: the smaller the number, the finer the grit – the larger the number, the coarser the grit.

The prefix "B" specifies CBN, the prefix "D" denotes Diamond; the US equivalents in Standard Mesh are also shown below.

Grit Size based on ISO 6106 resp. FEPA and US-Standard

CBN	Diamond	Grit size μm	US-Standard Mesh
B 46	D 46	38–45	325/400
B 54	D 54	45–53	270/325
B 64	D 64	53–63	230/270
B 76	D 76	63–75	200/230
B 91	D 91	75–90	170/200
B 107	D 107	90–106	140/170
B 126	D 126	106–125	120/140
B 151	D 151	125–150	100/120
B 181	D 181	150–180	80/100
B 213	D 213	180–212	70/80
B 251	D 251	212–250	60/70

When selecting the grit size, it must be remembered that ultrahard abrasive grain gives a coarser surface finish than conventional grit types; this is due to the extremely low wear rate. The most widely used grit sizes lie between 54 and 91 microns.

Always the right tool

For Highest Precision and Safety!



CBN-/Diamond Grinding Tools, vitrified bonded

369 Special features of the vitrified bond

369 Selection of qualities

370 Selection of mounted point dimensions

370 Chart for tungsten carbide shanks

371 Selection of wheel dimensions



Product line marking

Product lines are labelled in the table header with the appropriate tabs. Further information on page **14** and **15**.

Technical Information

Shanks

The various types of CBN mounted points in a vitrified bond are, without exception, supplied with tungsten carbide shanks; carbide has a module of elasticity three times greater than steel.

The elasticity module denotes the extent to which a body deforms under pressure. Carbide has a high module of elasticity and therefore the deflection of the tools resulting from grinding pressure is kept to a minimum.

There are considerable advantages, eg:

- Reduction of spark-out time; this means a shorter grinding cycle
- Considerable improvement in tool life
- Reduction in tooling and setting costs
- Improvement in surface finish of the workpiece
- Improvement in workpiece geometry

The following table illustrates the rigidity of steel and tungsten carbide shank material in relation to diameter and overhang. A 3 mm diameter steel shank with an overhang of 40 mm is used as the base rigidity value of „1“.

Dressing

There are two main reasons for dressing CBN/diamond tools:

1. To achieve geometrical accuracy.
2. To prevent dulling of the abrasive grain and to free the surface from loading, ie, to maintain a free-cutting tool.

These tools must be dressed wet with ample coolant!

Various dressing methods are used depending on the hardness of the tool. The softer wheel qualities can be dressed with either a single point diamond dresser, or a rotary silicon carbide/diamond wheel. Dressing infeeds are typically in the range of 0.2 mm.

The single point diamond dresser cannot be used for the „medium hard“ qualities. Dressing infeed is in the range of 50 – 200 µm. The harder specifications require dressing after only 50 – 500 workpieces depending on grinding parameters used. Dressing infeed is normally very small, ie, in the range of 2 to 10 microns.

A rotary diamond wheel dresser is used. Very hard qualities which require heavy dressing, need an additional dressing operation to „sharpen“ the tool; a soft silicon carbide rotary dresser is used. The cutting speed should not exceed 10 m/s.

Relative rigidity of steel/tungsten carbide shank

Steel shank 3 mm x 40 mm overhang represents the base rigidity value „1“

overhang mm	shank							
	3		6		8		10	
	Steel	TC	Steel	TC	Steel	TC	Steel	TC
10	64	183	1024	2932	3237	9266	7900	22635
20	8	23	128	367	405	1159	988	2828
40	1	2,9	16	46	51	145	123	354

unstable very stable

Technical Information

Selection of Qualities/CBN/Diamond abrasive tools, vitrified bonded

LUKAS vitrified bonded diamond tools are identified by a quality code which contains all data determining the specification. Please see below some typical specifications:

Quality code CBN	Size	Concentration	Characteristic
53.5*	B 46	C 175	medium
29*	B 54	C 150	universal
34.5	B 54	C 170	
71.1	B 54	C 185	
50.3*	B 64	C 200	very hard
70.7	B 76	C 190	hard
57.7*	B 76	C 175	fine
54.8*	B 91	C 140	medium
70.1	B 91	C 185	hard
46.3*	B 151	C 175	medium

Quality code Diamond	Size	Concentration	Characteristic
15 D	D 91	C 120	
15.4 D	D 91	C 165	hard
18 D*	D 151	C 120	

* = widely used specifications

LFG-bond = Low Force Grinding

We can recommend a suitable quality following receipt of application details.

Special features of the vitrified bond

Concentration

The letter "C" in the specification represents the grit concentration; this can vary quite considerably depending on the application. The concentration denotes the volume of ultrahard abrasive grain used in the tool; this determines the grinding effectiveness and the price.

The opposite table illustrates the range of concentration; the most popular are shown in bold figures.

Range of concentration

C	40	60	100	120	160	200	220
V*	100	150	250	300	400	500	550
Vol%	10	15	25	30	40	50	55

V* = Vol% x 10; this is also used to express concentration

370 CBN-/Diamond Grinding Tools, vitrified bonded, tailor-made solution



Industry

Selection of mounted point dimensions

Ordering example: CBN-Mounted Point, Quality 50.3, D 11 mm, Shank 8 x 70



* shank length, please see below

Diameter D	In Increments of	Width T	Shank options*/Diameter S
1,8 – 2,0 mm	0,1 mm	3 mm	2 – 3 mm
2,0 – 2,6 mm	0,1 mm	4 mm	2 – 3 mm
3,0 – 5,0 mm	0,1 mm	5 mm	2 – 5 mm
5,1 – 10,0 mm	0,1 mm	as D taken to nearest mm	4 – 10 mm
10,0 – 40,0 mm	1 mm	10 mm	4 – 12 mm



Industry

Chart for Tungsten carbide shanks

Ordering example: CBN-Mounted Point, Quality 50.3, D 11 mm, Shank 8 x 70

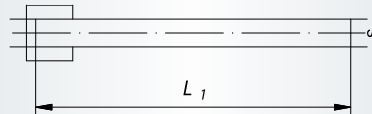

Shanks can be re-used

Shank-diameter S	Shank length (blank length) L ₁ mm									
	30	40	50	60	70	80	100	120	130	150
2 mm	30	40	50							
2,5 mm	30	40	55							
3 mm	30	40	50	60						
4 mm		40	50	60	70					
5 mm			50	60	70					
6 mm			50	60	70	80	100	120		
8 mm			50	60	70	80	100	120		
10 mm				60	70	80	100	120	130	150
12 mm						80	100	120		150

Bore and facegrinding possible see drawing above.

Selection of wheel dimensions and shapes

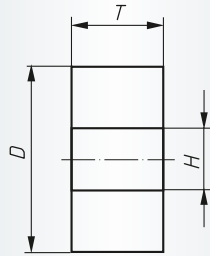

Type 1
unfinished (as fired)

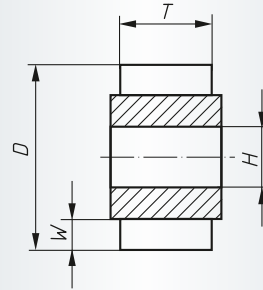

Type 2
plain steel core

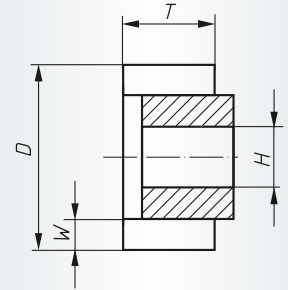

Type 3
steel core, 3 mm recessed

Due to technical reasons, the smallest dimensions for W is 5 mm.



Industry

Dimensions

Ordering example: CBN Wheel, Quality B 54 C 150 29, Type 3: D 35 x 10 mm, H 8 mm

When ordering please specify bore size „H“.

Minimum order quantity 10 pieces

Dimension D	In increments of D	Width		
14 to 25 mm	1 mm	10 mm	12 mm	15 mm
25 to 40 mm	5 mm	10 mm	12 mm	15 mm

Notes

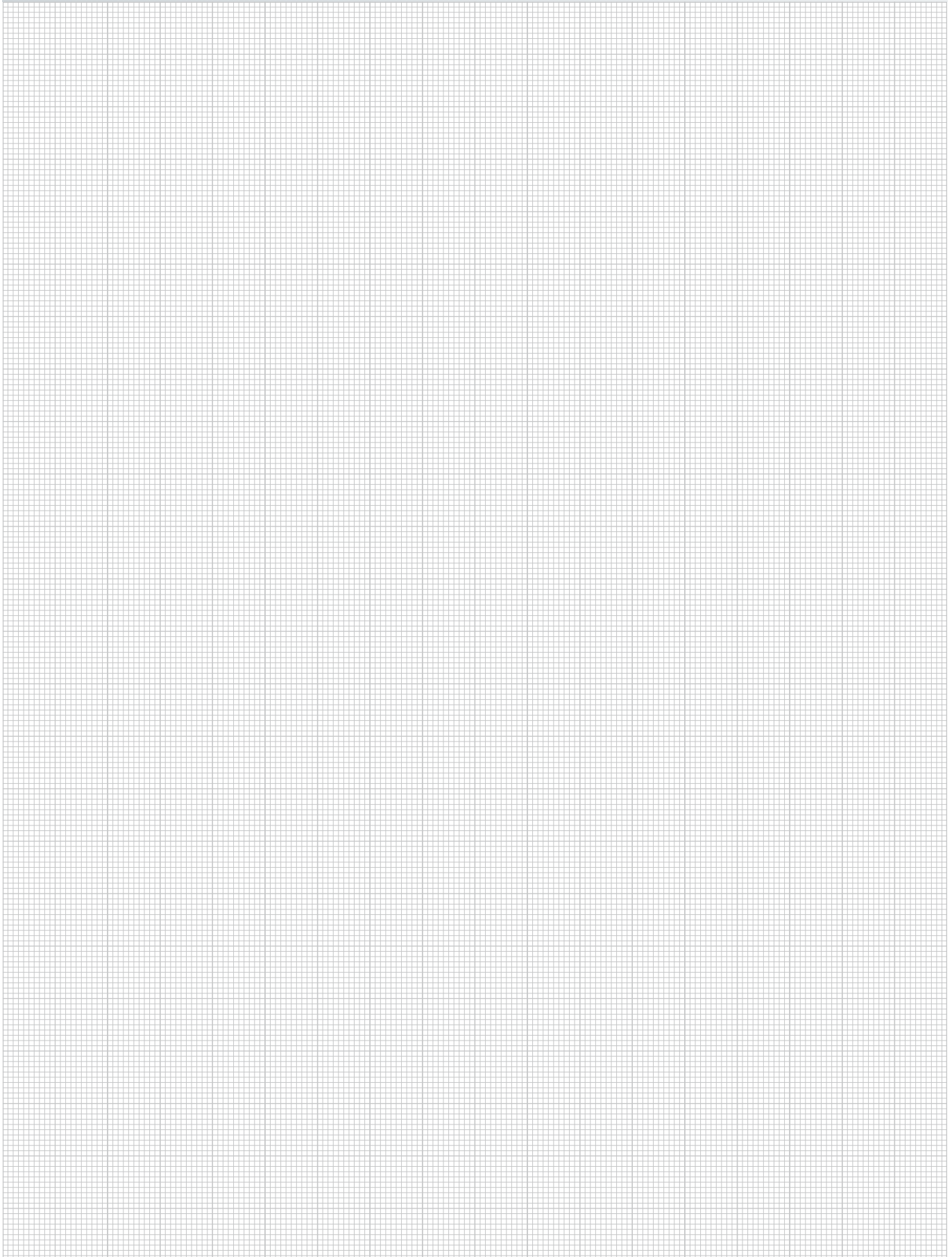

CBN-/Diamond Mounted Points, electro-plated

374 CBN-/Diamond points, cylindrical shape

375 Diamond points using solid carbide

375 CBN-/Diamond points, spherical shape

381 Power tool



Product line marking

Product lines are labelled in the table header with the appropriate tabs. Further information on page **14** and **15**.

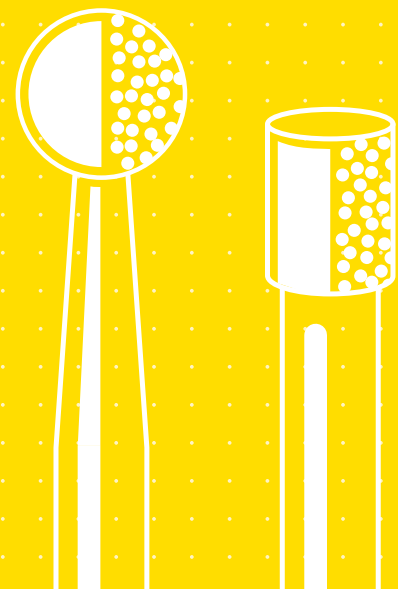

374 CBN-/Diamond Mounted Points, electro-plated



Industry

Diamond points cylindrical shape

Ordering example: A34013050126

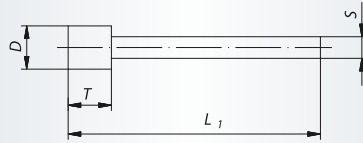

Packing unit:
1 pc. per type

Description	grit sizes	D mm	T mm	S mm	L ₁ mm	Product-Number	recommended for	
DS 01003	D 126	1	3	3	40	A34013050126	① ② ③ ④ ⑤ ⑦ ⑨	■
DS 01503	D 126	1,5	3	3	40	A34013051126	① ② ③ ④ ⑤ ⑦ ⑨	■
DS 02005	D 126	2	5	3	40	A34013052126	① ② ③ ④ ⑤ ⑦ ⑨	■
DS 02505	D 126	2,5	5	3	40	A34013053126	① ② ③ ④ ⑤ ⑦ ⑨	■
DS 03005	D 126	3	5	3	40	A34013054126	① ② ③ ④ ⑤ ⑦ ⑨	■
DS 03505	D 126	3,5	5	3	40	A3401305412601	① ② ③ ④ ⑤ ⑦ ⑨	■
DS 04005	D 126	4	5	3	40	A34013055126	① ② ③ ④ ⑤ ⑦ ⑨	■
DS 04505	D 126	4,5	5	3	40	A3401305512601	① ② ③ ④ ⑤ ⑦ ⑨	■
DS 05006	D 126	5	6	3	40	A34013056126	① ② ③ ④ ⑤ ⑦ ⑨	■
DS 06007	D 126	6	7	3	40	A34013057126	① ② ③ ④ ⑤ ⑦ ⑨	■
DS 08010	D 126	8	10	6	60	A34013058126	① ② ③ ④ ⑤ ⑦ ⑨	■
DS 10010	D 126	10	10	6	60	A34013059126	① ② ③ ④ ⑤ ⑦ ⑨	■
DS 12015	D 126	12	15	6	60	A34013060126	① ② ③ ④ ⑤ ⑦ ⑨	■



Industry

CBN points, cylindrical shape

Ordering example: A34033050126

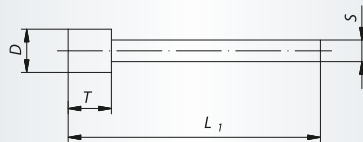

Packing unit:
1 pc. per type

Description	grit sizes	D mm	T mm	S mm	L ₁ mm	Product-Number	recommended for	
CS 01003	B 126	1	3	3	40	A34033050126	③ ④	■
CS 01503	B 126	1,5	3	3	40	A34033051126	③ ④	■
CS 02005	B 126	2	5	3	40	A34033052126	③ ④	■
CS 02505	B 126	2,5	5	3	40	A34033053126	③ ④	■
CS 03005	B 126	3	5	3	40	A34033054126	③ ④	■
CS 03505	B 126	3,5	5	3	40	A3403305412601	③ ④	■
CS 04005	B 126	4	5	3	40	A34033055126	③ ④	■
CS 04505	B 126	4,5	5	3	40	A3403305512601	③ ④	■
CS 05006	B 126	5	6	3	40	A34033056126	③ ④	■
CS 06007	B 126	6	7	3	40	A34033057126	③ ④	■
CS 08010	B 126	8	10	6	60	A34033058126	③ ④	■
CS 10010	B 126	10	10	6	60	A34033059126	③ ④	■
CS 12015	B 126	12	15	6	60	A34033060126	③ ④	■



Industry

Diamond points using solid carbide shanks, cylindrical shape

Ordering example: A340202305126

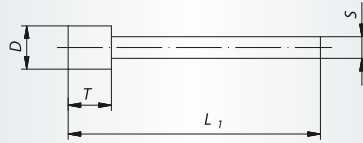

Packing unit:
1 pc. per type

Description	grit sizes	D mm	T mm	S mm	L ₁ mm	Product-Number	recommended for	
DSH 02303	D 126	2,3	3	2	75	A340202305126	① ② ③ ④ ⑤ ⑦ ⑨	■
DSH 03304	D 126	3,3	4	3	75	A340203303126	① ② ③ ④ ⑤ ⑦ ⑨	■
DSH 04305	D 126	4,3	5	4	75	A340204305126	① ② ③ ④ ⑤ ⑦ ⑨	■
DSH 06307	D 126	6,3	7	6	75	A340206307126	① ② ③ ④ ⑤ ⑦ ⑨	■
DSH 08310	D 126	8,3	10	8	75	A340208310126	① ② ③ ④ ⑤ ⑦ ⑨	■
DSH 10310	D 126	10,3	10	10	75	A340210310126	① ② ③ ④ ⑤ ⑦ ⑨	■



Industry

Diamond points, spherical shape

Ordering example: A34013090126

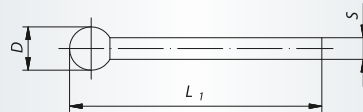

Packing unit:
1 pc. per type

Description	grit sizes	D mm	S mm	L ₁ mm	Product-Number	recommended for	
DSK 02020	D 126	2	3	40	A34013090126	① ② ③ ④ ⑤ ⑦ ⑨	■
DSK 03030	D 126	3	3	40	A34013091126	① ② ③ ④ ⑤ ⑦ ⑨	■
DSK 04040	D 126	4	3	40	A34013092126	① ② ③ ④ ⑤ ⑦ ⑨	■
DSK 05050	D 126	5	3	40	A34013093126	① ② ③ ④ ⑤ ⑦ ⑨	■
DSK 06060	D 126	6	3	40	A34013094126	① ② ③ ④ ⑤ ⑦ ⑨	■
DSK 08080	D 126	8	6	60	A34013095126	① ② ③ ④ ⑤ ⑦ ⑨	■

376 CBN-Points, electro-plated



Industry

CBN points, spherical shape

Ordering example: A34033090126

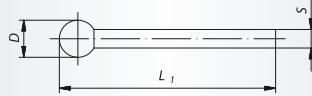

Packing unit:
1 pc. per type

Description	grit sizes	D mm	S mm	L ₁ mm	Product-Number	recommended for																
CSK 0202	B 126	2	3	40	A34033090126			③	④													■
CSK 0303	B 126	3	3	40	A34033091126			③	④													■
CSK 0404	B 126	4	3	40	A34033092126			③	④													■
CSK 0505	B 126	5	3	40	A34033093126			③	④													■
CSK 0606	B 126	6	3	40	A34033094126			③	④													■
CSK 0808	B 126	8	6	60	A34033095126			③	④													■

Diamond Files, electro-plated

378 Diamond files for off-hand filing machines

378 Diamond needle files

379 Diamond riffler files

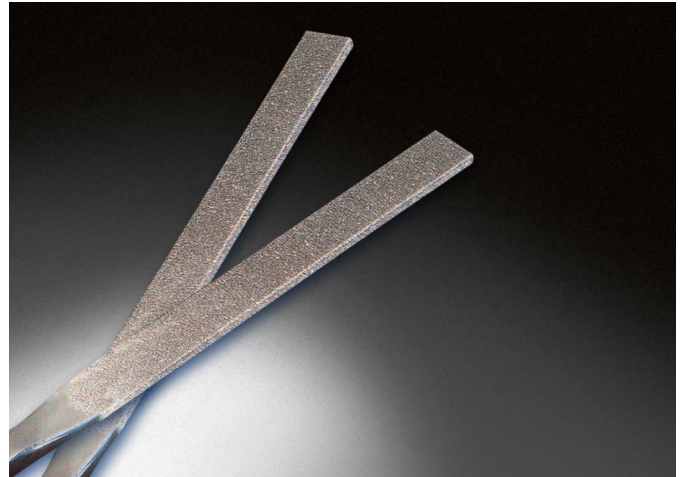

Product line marking

Product lines are labelled in the table header with the appropriate tabs. Further information on page **14** and **15**.

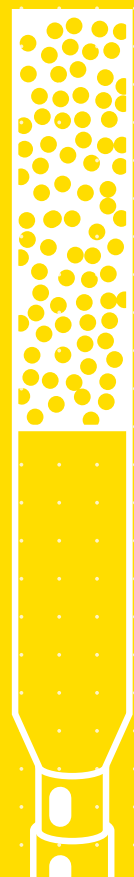



378 Diamond Files, electro-plated



Industry

Diamond files for off-hand filing machines

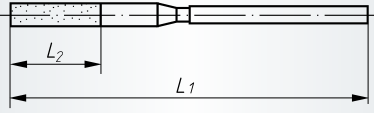
Ordering example: A34003122126









Description		Available profiles	A summary of available shapes	grit sizes	Cross section mm	L ₂ mm	L ₁ mm	Product-Number	recommended for	
 		Packing unit: 1 pc. per type								
DF 3122	flat, one side coated		D 126	4 x 1	15	50	A34003122126	① ② ③ ④ ⑤ ⑦ ⑨	■	
DF 3130	round		D 126	4	15	50	A34003130126	① ② ③ ④ ⑤ ⑦ ⑨	■	

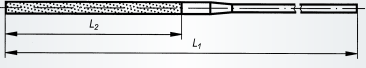

Industry

Diamond needle files

Ordering example: A34003140091

Description		Available profiles	A summary of available shapes	grit sizes	Cross section mm	L ₂ mm	L ₁ mm	Product-Number	recommended for	
 		Packing unit: 1 pc. per type								
DF 3140	flat		D 91	5,0 x 1,4	70	140	A34003140091	① ② ③ ④ ⑤ ⑦ ⑨	■	
DF 3140	flat		D 126	5,0 x 1,4	70	140	A34003140126	① ② ③ ④ ⑤ ⑦ ⑨	■	
DF 3142	triangular		D 91	3,5 x 3,5	70	140	A34003142091	① ② ③ ④ ⑤ ⑦ ⑨	■	
DF 3142	triangular		D 126	3,5 x 3,5	70	140	A34003142126	① ② ③ ④ ⑤ ⑦ ⑨	■	
DF 3143	square		D 126	2,5 x 2,5	70	140	A34003143126	① ② ③ ④ ⑤ ⑦ ⑨	■	
DF 3144	half-round		D 126	5,2 x 1,9	70	140	A34003144126	① ② ③ ④ ⑤ ⑦ ⑨	■	
DF 3145	round		D 126	3	70	140	A34003145126	① ② ③ ④ ⑤ ⑦ ⑨	■	
DF 3146	knife		D 126	5,0 x 1,4	70	140	A34003146126	① ② ③ ④ ⑤ ⑦ ⑨	■	



Industry

Diamond files, Rifflers

Ordering example: A34003110126

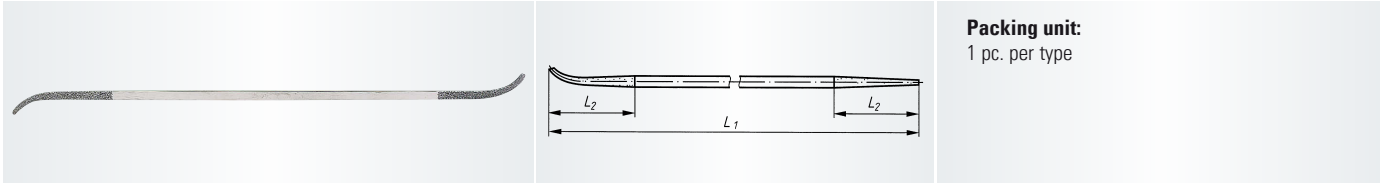

Packing unit:
1 pc. per type

Description	Available profiles	A summary of available shapes	grit sizes	Cross section mm	L ₂ mm	L ₁ mm	Product-Number	recommended for	
DF 3110	bird tongue		D 126	4 x 2	25	150	A34003110126	① ② ③ ④ ⑤ ⑦ ⑨	■
DF 3111	flat		D 126	3 x 1,5	25	150	A34003111126	① ② ③ ④ ⑤ ⑦ ⑨	■
DF 3112	square		D 126	2 x 2	25	150	A34003112126	① ② ③ ④ ⑤ ⑦ ⑨	■
DF 3113	triangular		D 126	3	25	150	A34003113126	① ② ③ ④ ⑤ ⑦ ⑨	■

What is your experience when using this tool?



SLTR Ceramic:
As a metal worker, I need a tool that lasts and that grinds quickly and easily. I'm really happy with SLTR Ceramic!



Moses Kasura
Engineering Department

www.lukas-erzett.com



My surface finishing experts

**Multi faceted.
Diverse competence.
A network.**



**Individual. Problem solver.
Innovative.**

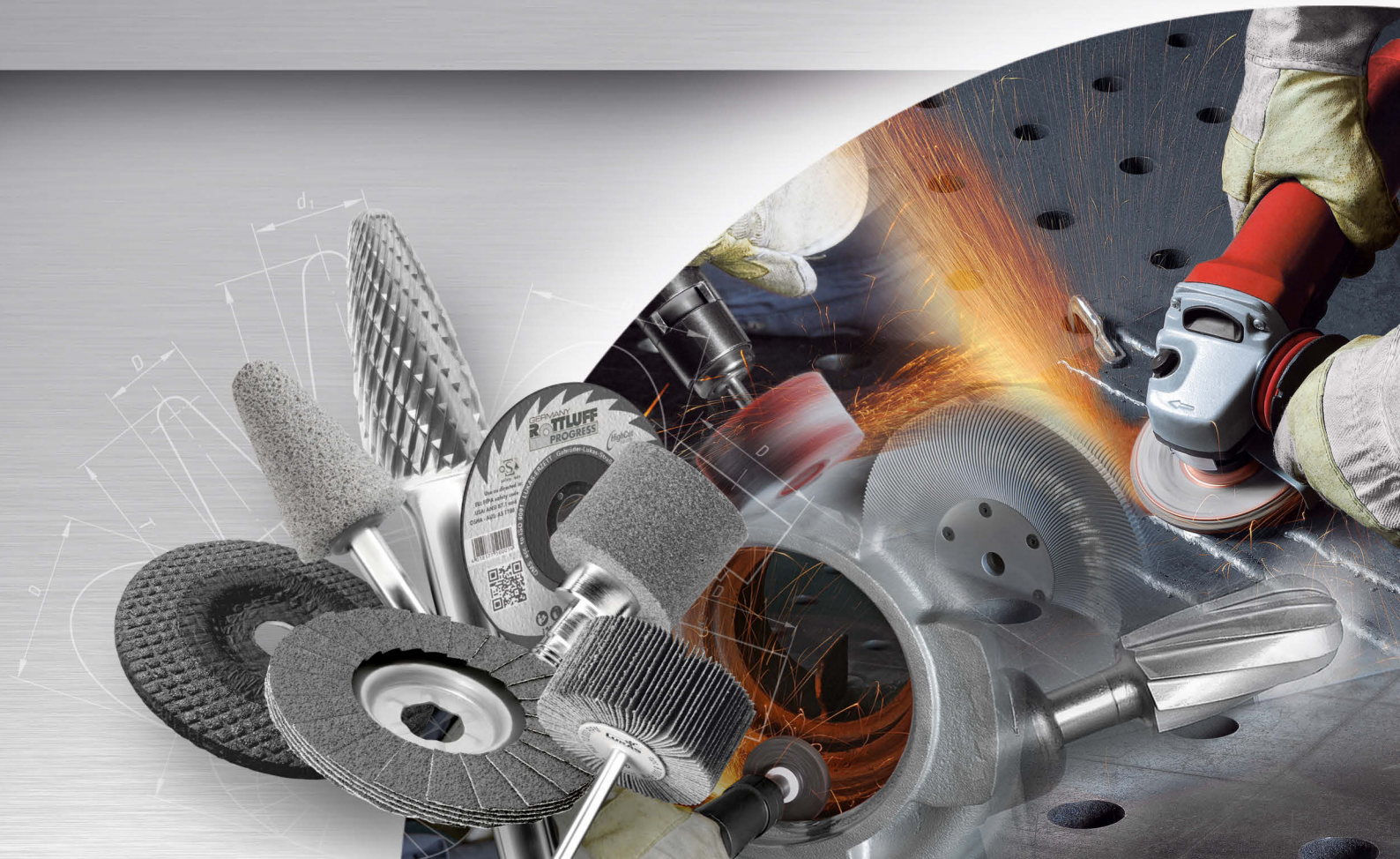

Air tools

382 Technical Information

Pneumatic Angle Grinders

384 Belt grinding machine

385 Straight grinder

Power tools

398 Conditioning machine



Product line marking

Product lines are labelled in the table header with the appropriate tabs. Further information on page **14** and **15**.



Technical Information

General information

High performance and low air consumption are the major features of LUKAS air tools. The robust vane motors can be stopped under load without causing any damage.

Speed governors are used to prevent exceeding of the idling speed within the specified tolerance.

The tool design is maintenance and service friendly. It facilitates the change of wear parts.

Compressed air supply

Power tools already achieve maximum performance levels from a flow pressure of 0.63 MPa (= 6.3 bar). We are more than happy to provide advise when it comes to the optimum design of your compressed air supply. Please refer to the technical information for initial specifications on line cross sections (diagram).

Air consumption (see machine data)	Connection thread
0,05–0,5 m ³ /min	¼" thread
0,15–0,9 m ³ /min	⅜" thread
0,5–1,5 m ³ /min	½" thread
0,8–6,0 m ³ /min	¾" thread

Vane motor lubrication

A maintenance unit consisting of a water trap and lubricator reliably protects the vane motors against wear, reduces the maintenance effort and increases the service life.

Turbo drive lubrication

Machines with a turbo drive are always operated without a lubricator!

As the rotation of the rotor in the machine housing is a widely non-contact motion, the results are particularly low friction losses and higher energy efficiency during grinding and milling.

Ergonomics and safety

Vibration

All air tools are tested and labelled in accordance with the current European noise and vibration directive to protect the user.

Vibrations are recorded and calculated three-dimensionally in this respect.

Ergonomics

When compared to electric power tools, pneumatic tools offer a higher level of performance and lower weight. Ergonomically shaped, insulated handles mean that the machines can be held easily, thus enabling fatigue-free working.

Machining of workpieces which are difficult to access also presents no problem with LUKAS pneumatic tools, as the spindle length, air outlet and valve design of many machines can be optimized to suit user requirements.

Safety

Use is even possible in potentially hazardous atmospheres.

Quality

All machines have a robust aluminium housing and are designed for use in a harsh environment. Motors do not overheat, even during continuous operation at a maximum performance level. In the context of 100% quality control all machines undergo speed and performance measurements prior to delivery.

Safety instruction

Only tools which are safe and approved for operation at the peripheral speeds achieved with respective tools should be used.

Overview of pneumatic angle grinders

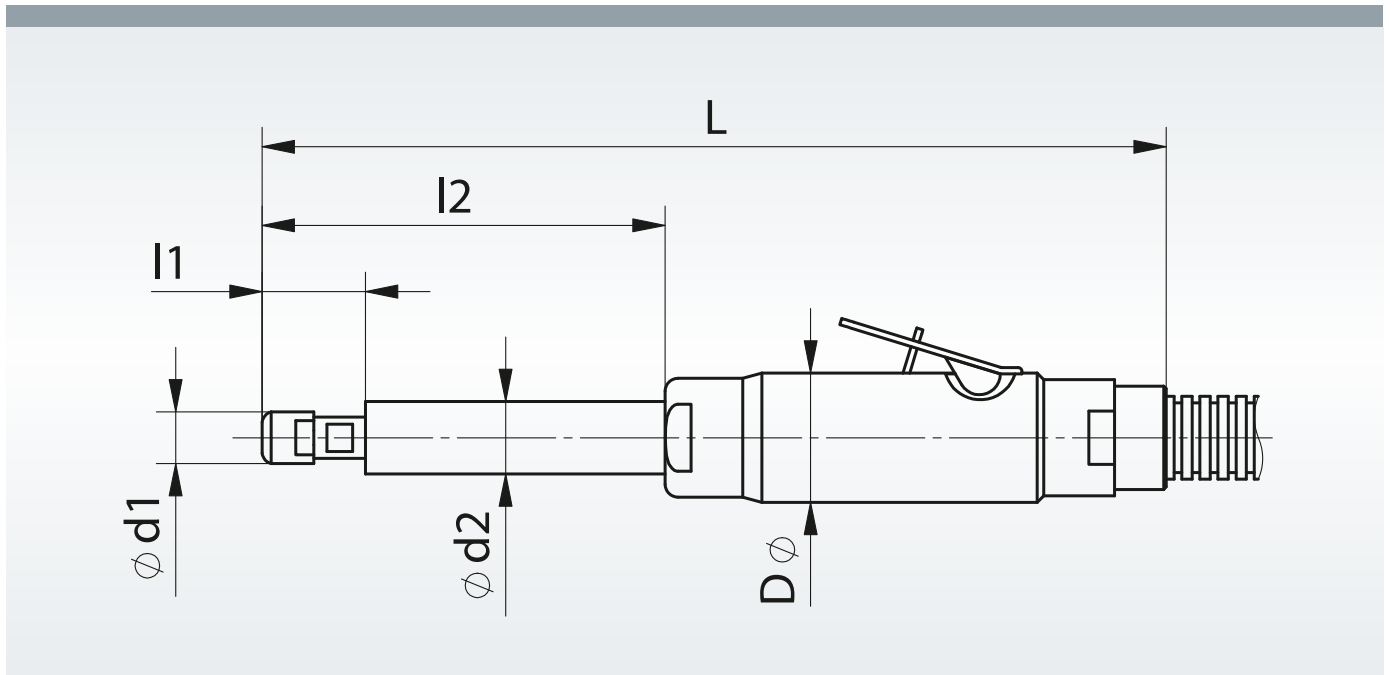

Technical specifications

Product name	Rotational speed/minute	Performance in kw	d1 mm	l1 mm	d2 mm	l2 mm	D mm	L mm	Page
AMIN 30 BSH	30.000	0,300	19	28	h = 86		35	220	384
AMIN 12-030 GD	12.000	0,300	16	26	---	---	35	195	385
AMIN 15-030 GD	15.000	0,300	16	26	---	---	35	195	385
AMIN 12-030 GH	12.000	0,300	16	26	---	---	35	195	385
AMIN 15-100 GH	15.300	1,000	24	37	34	148	51	350	386
AMIN 15-070 GH2L	15.300	0,700	24	35	24	440	46	630	387
AMIN 15-100 GHL	15.300	1,000	24	31	24	160	51	360	388
AMIN 19-100 GHL	19.000	1,000	24	31	24	160	51	360	388
AMIN 19-100 GH	19.000	1,000	24	37	34	148	51	350	389
AMIN 19-100 GHK	19.000	1,000	24	44	---	---	51	245	389
AMIN 20-030 GD	20.000	0,300	16	26	---	---	35	195	390
AMIN 23-030 GD	23.000	0,300	16	26	---	---	35	195	390
AMIN 20-030 GH	20.000	0,300	16	26	---	---	35	195	390
AMIN 30-030 GD	30.000	0,300	14	16	---	---	36	190	391
AMIN 30-030 GH	30.000	0,300	14	16	---	---	36	190	391
AMIN 32-027 GD	32.000	0,270	13	20	23	35	29	210	392
AMIN 45-030 GD	45.000	0,300	14	16	---	---	36	190	393
AMIN 45-030 GH	45.000	0,300	14	16	---	---	36	190	393
AMIN 55-011 GD	55.000	0,110	9	14	---	---	20	125	394
AMIN 72-013 GD	72.000	0,130	10	15	---	---	29	165	395
AMIN 70-025 TGD	70.000	0,250	14	16	---	---	42	175	396
AM 07/100 GH	7.600	1,500	63	15	51	130	74	530	397
AM 11/080 GH	10.700	1,100	40	10	47	110	62	498	397



Abrasive belt grinder – insulated

Ordering example: A3993302113



Length: approx. 325 mm
Height: approx. 86 mm
Weight: approx. 0,90 kg
Drive: vane motor

For more technical specifications see page 383.

Description	Valve	Idle speed min ⁻¹	Power consumption KW	Air consumption under load m ³ /min	Belt peripheral speed m/s	Hose-nominal size mm	Product-Number	
AMIN 30 BSH	Lever	30.000	0,3	0,45	28	6	A3993302113	■

Included with the machine:

an abrasive belt mounting arm for long belts in dimension 13 x 305 mm, inlet and exhaust air hoses plus silencer, collet for 6 mm, spanner

Extra equipment:

collets for Ø 3 mm, 4 mm, 5 mm, 1/8", 3/16", 1/4"
 Abrasive belt extensions in various sizes (lengths, widths and roll diameters) available ex stock.

Available ex-stock:

long belts 13 x 305 mm

Suited to LUKAS tools:

Please take note of the relevant RPM stated on our packing material.



SBL, finishing belts

Ordering example: A3000130305040T01



Packing unit:

100 pcs. per type
 Peripheral speed: 28 m/s
 NK = reg. Aluminium Oxide
 ZK = Zirconia Alum. Oxide

Description	Grits	B mm	Length mm	Lining	Product-Number	recommended for	
SBLT	ZK 40	13	305	robust-flexible	A3000130305040T01	① ② ③ ④ ⑤ ⑧	■
SBLT	NK 60	13	305	robust-flexible	A3000130305060T	① ② ③ ④ ⑤ ⑥ ⑦ ⑧	■
SBLT	ZK 60	13	305	robust-flexible	A3000130305060T01	① ② ③ ④ ⑤ ⑧	■
SBLT	NK 80	13	305	robust-flexible	A3000130305080T	① ② ③ ④ ⑤ ⑥ ⑦ ⑧	■
SBLX	NK 80	13	305	robust	A3000130305080X	① ② ③ ④ ⑤ ⑥ ⑦ ⑧	■
SBLT	ZK 80	13	305	robust-flexible	A3000130305080T01	① ② ③ ④ ⑤ ⑧	■
SBLT	NK 120	13	305	robust-flexible	A3000130305120T	① ② ③ ④ ⑤ ⑥ ⑦ ⑧	■
SBLX	NK 120	13	305	robust	A3000130305120X	① ② ③ ④ ⑤ ⑥ ⑦ ⑧	■



Straight grinder – insulated

Ordering example: A3993101112



Length: approx. 175 mm
Diameter: 34,5 mm
Weight: approx. 0,90 kg
Drive: vane motor
 Integral speed regulator

For more technical specifications see page 383.

Description	Valve	Idle speed min ⁻¹	Power consumption KW	Air consumption under load m ³ /min	Collet dia Ø mm	Hose-nominal size mm	Product-Number	
AMIN 12-030 GD	Twist	12.000	0,3	0,49	6	8	A3993101112	■
AMIN 12-030 GH	Lever	12.000	0,3	0,49	6	8	A3993102112	■
AMIN 15-030 GD	Twist	15.000	0,3	0,52	6	8	A3993101115003	■

Included with the machine:

inlet and exhaust air hoses plus silencer, 6 mm collet and spanner

Extra equipment:

collets for Ø 3 mm, 4 mm, 5 mm, 1/8", 3/16", 1/4"

Suited to LUKAS tools: Please take note of the relevant RPM stated on our packing material.	Dimension	Page
AMIN 12-030 GD/GH		
Tungsten Carbide Burrs	up to Ø 20 mm	from 25
Burrs of HSS	up to Ø 8 mm	from 63
Mounted flap wheels SFV/M	Ø 40 mm	from 277
Mounted flap wheels SFI	Ø 30 mm	271
Mounted flap wheels SFA	Ø 15 mm, 20 mm, 30 mm	272
Abrasive Belts SBZY	up to Ø 30 mm	from 303
Abrasive Belts SBKE	up to Ø 36 mm	311
Abrasive Rolls SRZY/SRKE	up to Ø 20 mm	from 317
Abrasive Caps SK...	up to Ø 21 mm	from 321
Abrasive Sleeves SHKE	0885, 1385, 1885	329
Polishing Points P1	4020	from 137
Polishing Points P2	Ø 20 mm	from 140
Polishing Points P5	Ø 40 mm	from 153
AMIN 15-030 GD		
Tungsten Carbide Burrs	up to Ø 16 mm	from 25
Burrs of HSS	up to Ø 6 mm	from 63
Mounted flap wheels SFI	Ø 30 mm	271
Mounted flap wheels SFA	Ø 15 mm, 20 mm, 30 mm	272
Abrasive Belts SBZY	up to Ø 25 mm	from 303
Abrasive Belts SBKE	up to Ø 29 mm	311
Abrasive Rolls SRZY/SRKE	up to Ø 20 mm	from 317
Abrasive Caps SK...	up to Ø 16 mm	from 321
Abrasive Sleeves SHKE	0885, 1385	329



Straight grinder – insulated

Ordering example: A3993102115



Length: approx. 310 mm
Diameter: 52 mm
Weight: approx. 2,3 kg
Drive: vane motor
 Integral speed regulator

For more technical specifications see page 383.

Description	Valve	Idle speed min ⁻¹	Power consumption KW	Air consump- tion under load m ³ /min	Collet dia Ø mm	Hose-nominal size mm	Product-Number	
AMIN 15-100 GH	Lever	15.300	1	1	6	12	A3993102115	■

Included with the machine:

inlet and exhaust air hoses plus silencer, 6 mm collet and spanner

Extra equipment:

collets for Ø 8 mm, 9 mm, 3/16", 1/4", 5/16"

Suited to LUKAS tools: Please take note of the relevant RPM stated on our packing material.	Dimension	Page
Tungsten Carbide Burrs	up to Ø 16 mm	from 25
Burrs of HSS	up to Ø 6 mm	from 63
Mounted Points	up to Ø 60 mm	from 93
Polishing Points P2	up to Ø 16 mm	from 140
Polishing Points P3	up to Ø 16 mm	from 144
Polishing Points P6	up to Ø 30 mm	from 157
Mounted flap wheels SFL/SFE/SFB/SFT/SFC	up to Ø 40 mm	from 261
Abrasive Caps SK...	up to Ø 16 mm	from 321
Abrasive Rolls SR...	up to Ø 20 mm	from 317
Abrasive Belts SBZY	up to Ø 22 mm	from 303
Abrasive Belts SBKE	up to Ø 29 mm	311



Straight grinder with spindle extension – insulated

Ordering example: A3993102115002



Length: approx. 615 mm¹⁾
Diameter: 47 mm
Weight: approx. 2,1 kg
Drive: vane motor
 Integral speed regulator

¹⁾ Dimension with two spindle extensions

For more technical specifications see page 383.

Description	Valve	Idle speed min ⁻¹	Power consumption KW	Air consumption under load m ³ /min	Collet dia Ø mm	Hose-nominal size mm	Product-Number	
AMIN 15-070 GH2L	Lever	15.300	0,7	0,7	6	10	A3993102115002	■

Included with the machine:

inlet and exhaust air hoses plus silencer, two spindle extensions (each 200 mm long), collet 6 mm and spanner

Extra equipment:

spindle extension: 200 mm (max. length of spindle extensions up to 1.200 mm), collets for Ø 8 mm, 9 mm, 3/16", 1/4", 5/16"



Suited to LUKAS tools: Please take note of the relevant RPM stated on our packing material.	Dimension	Page
Mounted flap wheels SFL/B/T/E/C	up to Ø 40 mm	from 261
Mounted flap wheels SFI	Ø 30 mm	271
Mounted flap wheels SFA	Ø 15 mm, 20 mm, 30 mm	272
Abrasive Belts SBZY	up to Ø 25 mm	from 303
Abrasive Belts SBKE	up to Ø 29 mm	311
Abrasive Rolls SRZY/SRKE	up to Ø 20 mm	from 317
Abrasive Caps SK...	up to Ø 16 mm	from 321
Abrasive Sleeves SHKE	0885, 1385	329
Polishing Points P1	Ø 32 mm	from 137
Polishing Points P2	Ø 16 mm	from 140



Straight grinder – insulated

Ordering example: A3993102115001



Length: approx. 310 mm
Diameter: 52 mm
Weight: approx. 2,2 kg
Drive: vane motor
 Integral speed regulator

For more technical specifications see page 383.

Description	Valve	Idle speed min ⁻¹	Power consumption KW	Air consumption under load m ³ /min	Collet dia Ø mm	Hose-nominal size mm	Product-Number	
AMIN 15-100 GHl	Lever	15.300	1	1	6	12	A3993102115001	■
AMIN 19-100 GHl	Lever	19.000	1	1	6	12	A3993102119002	■

Included with the machine:

inlet and exhaust air hoses plus silencer, collet 6 mm and spanner

Extra equipment:

collets for Ø 8 mm, 9 mm, 3/16", 1/4", 5/16"

Suited to LUKAS tools: Please take note of the relevant RPM stated on our packing material.	Dimension	Page
AMIN 15-100 GHl		
Mounted flap wheels SFL/B/T/E/C	up to Ø 40 mm	from 261
Mounted flap wheels SFl	Ø 30 mm	271
Mounted flap wheels SFA	Ø 15 mm, 20 mm, 30 mm	272
Abrasive Belts SBZY	up to Ø 25 mm	from 303
Abrasive Belts SBKE	up to Ø 29 mm	311
Abrasive Rolls SRZY/SRKE	up to Ø 20 mm	from 317
Abrasive Caps SK...	up to Ø 16 mm	from 321
Abrasive Sleeves SHKE	0885, 1385	329
AMIN 19-100 GHl		
Mounted Points	Ø 50 mm	from 93
Mounted flap wheels SFL	Ø 20 mm	from 261
Abrasive Belts SBZY	up to Ø 19 mm	from 303
Abrasive Belts SBKE	up to Ø 29 mm	311
Abrasive Rolls SRZY/SRKE	up to Ø 13 mm	from 317
Abrasive Caps SK...	up to Ø 13 mm	from 321
Abrasive Sleeves SHKE	0885	329



Straight grinder – insulated

Ordering example: A3993102119



Length AMIN 19-100 GH: approx. 310 mm
Length AMIN 19-100 GHK: approx. 190 mm
Diameter: 52 mm
Weight GH: approx. 2,3 kg
Weight GHK: approx. 1,7 kg
Drive: vane motor
 Integral speed regulator

For more technical specifications see page 383.

Description	Valve	Idle speed min ⁻¹	Power consumption KW	Air consumption under load m ³ /min	Collet dia Ø mm	Hose-nominal size mm	Product-Number	
AMIN 19-100 GH	Lever	19.000	1	1	6	12	A3993102119	■
AMIN 19-100 GHK	Lever	19.000	1	1	6	12	A3993102119001	■

Included with the machine:

inlet and exhaust air hoses plus silencer, collet 6 mm and spanner

Extra equipment:

collets for Ø 8 mm, 9 mm, 3/16", 1/4", 5/16"

Suited to LUKAS tools: Please take note of the relevant RPM stated on our packing material.	Dimension	Page
Tungsten Carbide Burrs	up to Ø 12 mm	from 25
Burrs of HSS	up to Ø 4 mm	from 63
Mounted Points	up to Ø 50 mm	from 93
Polishing Points P1	up to Ø 50 mm	from 137
Polishing Points P2	up to Ø 12 mm	from 140
Polishing Points P3	up to Ø 10 mm	from 144
Polishing Points P5	up to Ø 50 mm	from 153
Polishing Points P6	up to Ø 16 mm	from 157
Abrasive Caps SK...	up to Ø 13 mm	from 321
Abrasive Rolls SR...	up to Ø 13 mm	from 317
Abrasive Belts SBZY	up to Ø 19 mm	from 303
Abrasive Belts SBKE	up to Ø 29 mm	311



Straight grinder – insulated

Ordering example: A3993101120



Length: approx. 175 mm
Diameter: 34,5 mm
Weight: approx. 0,90 kg
Drive: vane motor
 Integral speed regulator

For more technical specifications see page 383.

Description	Valve	Idle speed min ⁻¹	Power consumption KW	Air consumption under load m ³ /min	Collet dia Ø mm	Hose-nominal size mm	Product-Number	
AMIN 20-030 GD	Twist	20.000	0,3	0,53	6	8	A3993101120	■
AMIN 20-030 GH	Lever	20.000	0,3	0,45	6	8	A3993102120	■
AMIN 23-030 GD	Twist	23.000	0,3	0,54	6	8	A3993101123	■

Included with the machine:

inlet and exhaust air hoses plus silencer, collet 6 mm and spanner

Extra equipment:

collets for Ø 3 mm, 4 mm, 5 mm, 1/8", 3/16", 1/4"

Suited to LUKAS tools: Please take note of the relevant RPM stated on our packing material.	Dimension	Page
AMIN 20-030 GD/GH		
Tungsten Carbide Burrs	up to Ø 12 mm	from 25
Burrs of HSS	up to Ø 4 mm	from 63
Mounted flap wheels SFL	Ø 20 mm	from 261
Abrasive Belts SBZY	up to Ø 19 mm	from 303
Abrasive Belts SBKE	up to Ø 29 mm	311
Abrasive Rolls SRZY/SRKE	up to Ø 13 mm	from 317
Abrasive Caps SK...	up to Ø 13 mm	from 321
Abrasive Sleeves SHKE	0885	329
Mounted Points Shank 6 mm	Ø 22 mm, 25 mm, 32 mm, 40 mm	from 93
Polishing Points P2	Ø 13 mm	from 140
AMIN 23-030 GD		
Tungsten Carbide Burrs	up to Ø 12 mm	from 25
Burrs of HSS	up to Ø 4 mm	from 63
Abrasive Belts SFL	Ø 20 mm	from 261
Abrasive Belts SBZY	up to Ø 15 mm	from 303
Abrasive Rolls SRZY/SRKE	up to Ø 13 mm	from 317
Abrasive Caps SK...	up to Ø 13 mm	from 321
Abrasive Sleeves SHKE	0885	329
Mounted Points	up to Ø 40 mm	from 93
Polishing Points P1	Ø 10–20 mm	from 137
Polishing Points P2	Ø 5–10 mm	from 140
Polishing Points P5	Ø 8–20 mm	from 153



Straight grinder – insulated

Ordering example: A3993101130



Length: approx. 175 mm
Diameter: 34,5 mm
Weight: approx. 0,70 kg
Drive: vane motor
 Integral speed regulator

For more technical specifications see page 383.

Description	Valve	Idle speed min ⁻¹	Power consumption KW	Air consumption under load m ³ /min	Collet dia Ø mm	Hose-nominal size mm	Product-Number	
AMIN 30-030 GD	Twist	30.000	0,3	0,45	6	6	A3993101130	■
AMIN 30-030 GH	Lever	30.000	0,3	0,45	6	6	A3993102130	■

Included with the machine:

inlet and exhaust air hoses plus silencer, collet 6 mm and spanner

Extra equipment:

collets for Ø 3 mm, 3,25 mm, 4 mm, 5 mm, 1/8", 3/16", 1/4"

Suited to LUKAS tools: Please take note of the relevant RPM stated on our packing material.	Dimension	Page
Tungsten Carbide Burrs	up to Ø 8 mm	from 25
Burrs of HSS	up to Ø 3 mm	from 63
Mounted Points	up to Ø 32 mm	from 93
Polishing Points P1	up to Ø 32 mm	from 137
Polishing Points P2	up to Ø 10 mm	from 140
Polishing Points P3	up to Ø 10 mm	from 144
Polishing Points P5	up to Ø 32 mm	from 153
Polishing Points P6	up to Ø 12 mm	from 157
Abrasive Caps SK...	up to Ø 10 mm	from 321
Abrasive Belts SBZY	up to Ø 12 mm	from 303



Straight grinder, insulated

Ordering example: A3993101132



Length: approx. 206 mm
Body diameter: approx. 30 mm
Spindle casing diameter: approx. 23 mm
Weight: approx. 0,40 Kg
Drive: vane motor
Partial front exhaust (can be restricted)

For more technical specifications see page 383.

Description	Valve	Idle speed min ⁻¹	Power consumption KW	Air consumption under load m ³ /min	Collet dia Ø mm	Hose-nominal size mm	Product-Number	
AMIN 32-027 GD	Twist	32.000	0,27	0,3	6	6	A3993101132	■

Included with the machine:

inlet and exhaust air hoses plus silencer, collet 6 mm and spanner

Extra equipment:

collets for Ø 3 mm, 1/8", 1/4"

Suited to LUKAS tools: Please take note of the relevant RPM stated on our packing material.	Dimension	Page
Tungsten Carbide Burrs	up to Ø 8 mm	from 25
Burrs of HSS	up to Ø 3 mm	from 63
Mounted Points	up to Ø 32 mm	from 93
Polishing Points P1	up to Ø 32 mm	from 137
Polishing Points P2	up to Ø 10 mm	from 140
Polishing Points P3	up to Ø 10 mm	from 144
Polishing Points P5	up to Ø 32 mm	from 153
Polishing Points P6	up to Ø 12 mm	from 157
Abrasive Caps SK...	up to Ø 10 mm	from 321
Abrasive Belts SBZY	up to Ø 12 mm	from 303



Straight grinder – insulated

Ordering example: A3993101145



Length: approx. 175 mm
Diameter: 34,5 mm
Weight: approx. 0,70 kg
Drive: vane motor

For more technical specifications see page 383.

Description	Valve	Idle speed min ⁻¹	Power consumption KW	Air consumption under load m ³ /min	Collet dia Ø mm	Hose-nominal size mm	Product-Number	
AMIN 45-030 GD	Twist	45.000	0,3	0,5	6	6	A3993101145	■
AMIN 45-030 GH	Lever	45.000	0,3	0,5	6	6	A3993102145	■

Included with the machine:

inlet and exhaust air hoses plus silencer, collet 6 mm and spanner

Extra equipment:

collets for Ø 3 mm, 3,25 mm, 4 mm, 5 mm, 1/8", 3/16", 1/4"

Suited to LUKAS tools: Please take note of the relevant RPM stated on our packing material.	Dimension	Page
Tungsten Carbide Burrs	up to Ø 6 mm	from 25
Mounted Points	up to Ø 20 mm	from 93
Polishing Points P1	up to Ø 20 mm	from 137
Polishing Points P2	up to Ø 6 mm	from 140
Polishing Points P3	up to Ø 6 mm	from 144
Polishing Points P5	up to Ø 20 mm	from 153
Polishing Points P6	up to Ø 10 mm	from 157
Abrasive Caps SK...	up to Ø 5 mm	from 321
Abrasive Belts SBZY	up to Ø 12 mm	from 303



Straight grinder – insulated

Ordering example: A3993101155



Length: approx. 130 mm
Diameter: 16 mm
Weight: approx. 0,24 kg
Drive: vane motor

For more technical specifications see page 383.

Description	Valve	Idle speed min ⁻¹	Power consumption KW	Air consump- tion under load m ³ /min	Collet dia Ø mm	Hose-nominal size mm	Product-Number	
AMIN 55-011 GD	Twist	55.000	0,11	0,15	3	5	A3993101155	■

Included with the machine:

inlet and exhaust air hoses plus silencer, collet 3 mm and spanner

Extra equipment:

collets for Ø 2 mm, 3,25 mm, 1/8", 3/32"

Characteristics:

- Highest powered machine in its class
- Compact design
- Lockable rotary switch

Suited to LUKAS tools:

Please take note of the relevant RPM stated on our packing material.

Dimension

Page

Tungsten Carbide Burrs	up to Ø 5 mm	from 25
Mounted Points	up to Ø 16 mm	from 93
Polishing Points P1	up to Ø 16 mm	from 137
Polishing Points P2	up to Ø 5 mm	from 140
Polishing Points P5	up to Ø 16 mm	from 153
Abrasive Caps SK...	up to Ø 5 mm	from 321
Abrasive Belts SBZY	up to Ø 10 mm	from 303



Straight grinder – insulated

Ordering example: A3993101172



Length: approx. 154 mm
Diameter: 27,5 mm
Weight: approx. 0,45 kg
Drive: vane motor

For more technical specifications see page 383.

Description	Valve	Idle speed min ⁻¹	Power consumption KW	Air consumption under load m ³ /min	Collet dia Ø mm	Hose-nominal size mm	Product-Number	
AMIN 72-013 GD	Twist	72.000	0,13	0,21	3	5	A3993101172	■

Included with the machine:

inlet and exhaust air hoses plus silencer, collet 3 mm and spanner

Extra equipment:

collets for Ø 2 mm, 3,25 mm, 1/8", 3/32"

Suited to LUKAS tools: Please take note of the relevant RPM stated on our packing material.	Dimension	Page
Tungsten Carbide Burrs	up to Ø 4 mm	from 25
Mounted Points	up to Ø 13 mm	from 93
Polishing Points P1	up to Ø 13 mm	from 137
Polishing Points P2	up to Ø 4 mm	from 140
Polishing Points P5	up to Ø 13 mm	from 153



Turbo driven straight grinder – insulated

Ordering example: A3993101170



Length: approx. 170 mm
Diameter: Ø 20,6 mm, Ø 41,5 mm
Weight: approx. 0,6 kg
Drive: turbo
 Integral speed regulator

For more technical specifications see page 383.

Description	Valve	Idle speed min ⁻¹	Power consumption KW	Air consumption under load m ³ /min	Collet dia Ø mm	Hose-nominal size mm	Product-Number	
AMIN 70-025 TGD	Twist	70.000	0,25	0,43	3	6	A3993101170	■

Features:

- **Oil-free** and low maintenance
- Optimum weight for performance
- Integrated speed controller
- Automatic braking system to prevent overrun
- Lockable rotary switch

Included with the machine:

inlet and exhaust air hoses plus silencer, collet 3 mm and spanner

Extra equipment:

collets for Ø 4 mm, 5 mm, 6 mm, 1/8", 3/16", 1/4"

Suited to LUKAS tools: Please take note of the relevant RPM stated on our packing material.	Dimension	Page
Tungsten Carbide Burrs	up to Ø 4 mm	from 25
Mounted Points	up to Ø 13 mm	from 93
Polishing Points P1	up to Ø 8 mm	from 137
Polishing Points P2	up to Ø 4 mm	from 140
Polishing Points P5	up to Ø 6 mm	from 153



Straight grinder for grinding wheels tapered both sides

Ordering example: A79901021076



AM 07/100 GH

Length: approx. 530 mm
Diameter: 74 mm
Weight: approx. 3,8 kg
Drive: vane motor; Integral speed regulator

AM 11/080 GH

Length: approx. 498 mm
Diameter: 62 mm
Weight: approx. 2,2 kg
Drive: vane motor; Integral speed regulator

For more technical specifications see page 383.

Description	Valve	Idle speed min ⁻¹	Power consumption KW	Air consumption under load m ³ /min	max. grinding wheel Ø mm	tool fitting mm	Hose-nominal size mm	max. peripheral speed m/s	Product-Number	
AM 07/100 GH	Lever	7.600	1,5	1,6	125 x 25	20	13	50	A79901021076	■
AM 11/080 GH	Lever	10.700	1,1	1,3	80 x 20	20	13	50	A39901012115001	■

Included with the machine:

connector for inlet hose with internal Ø 13 mm, mounting flange to suit grinding wheels tapered both sides and spanner

These straight grinders in conjunction with LUKAS grinding wheels are ideal for removing weld seams and flashes on castings. Grinding with double-sided tapered fettling wheels is permitted without the use of a wheel guard, but only when the special flanges are used; wheel blotters are not necessary. This type of machine is

equipped with safety flanges. Both flanges cannot be loosened due to the rotational direction of the spindle; even if the machine becomes jammed, the wheel will not become loose.

Suited to LUKAS tools: Please take note of the relevant RPM stated on our packing material.	Dimension	Page
AMIN 07/100 GH Grinding wheel SE4	Ø 100–125 mm, Bore 20 mm	208
AMIN 11/080 GH Grinding wheel SE4	Ø 80 mm, Bore 20 mm	208



Conditioning machine

Ordering example: A3995ESM1310



Weight: approx. 2,8 kg

Description	Idle speed min-1	Power input W	Max. tool diameter Ø mm	Tool width mm	Hole size mm	Product-Number	
ESM 1310	1.300 - 3.050	1.300	120	100	19	A3995ESM1310	■

In conjunction with the appropriate tool, ideal for:

- Satin finishing
- Polishing
- Smoothing
- Matt finishing
- Conditioning
- Brushing
- Deburring

Special features :

- Highly resilient motor (stable)
- Dual gear reduction (long service life)
- Dust-protected bearings (low wear)

Versatility due to electric motor allowing a wide selection of spindle speeds. In conjunction with the optimal tooling, a shadow free and uniform surface can be achieved on metal, wood and plastic.

Electronic control:

- Soft start
- Infinitely variable speed control
- Temperature and overload cut-off

Suited to LUKAS tools:	Dimension	Page
Please take note of the relevant RPM stated on our packing material.		
Polishing Roll P6	100 x 50 mm, 100 x 100 mm	from 160
Grinding Rolls SBZY	100 x 100 mm	312
Flap Rolls LWL, LWV, LWM, LWF	100 x 50 mm, 100 x 100 mm	from 297

Product selection for retailers, assortments and accessories

400 Sales promotion and Product selection for retailers

410 Arbors for Felt Polishing Wheels

410 Arbors for tools with internal thread

411 Mounting arbors for small cutting-off wheels

411 Mounting system for polishing wheels

412 Adapter for SFI and SFA

412 Reducing bushes

413 Handstones

414 Tool-sets

424 Health and safety equipment

Product line marking

Product lines are labelled in the table header with the appropriate tabs. Further information on page **14** and **15**.

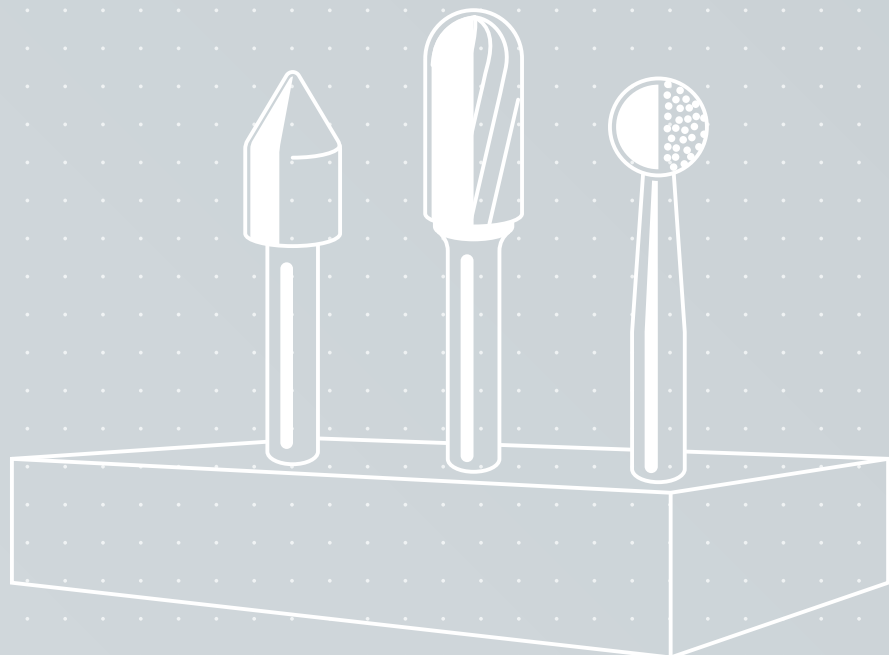

Your added value through sales promotion by Lukas

As a specialised dealer, you are well aware of your customers' requests! That is why you also want to present and sell Lukas products in a manner individually tailored to suit these customer requests. Take advantage of Lukas presentation options to enhance your sales of industrial tools for cutting, milling, grinding or polishing on a sustainable level!



The Lukas display panel

Stable self-supporting presentation stand with perforated panel. Assemble your own individual display panel with hook hangers for Euro hole packaging, hook hangers for all products with a hole, a brochure pocket for further information or suspended shelves for carton packaging to create a consistent product presentation.

The POS cardboard counter display for cutting discs or mounted flap wheels

Rapidly assembled for your presentation of unique Lukas mounted flap wheels or cutting and grinding discs on your sales counter. Selectively available for tools with a diameter of 115 mm or 125 mm

The POS counter display for tungsten carbide burrs

Lockable display for presentation and individual sale of valuable Lukas tungsten carbide burrs with a 3 mm or 6 mm shank. Suitable for your counter or sales shelves.

Attractive and informative individual packing

for the most popular Lukas tools, such as flap discs in the patented iQ-Series, tungsten carbide burrs, mounted flap wheels with shank made of abrasive cloth, abrasive fleece or a combination and the mounted points assortment for steel or stainless steel, all individually packaged and with a Euro hole, is available for your individual "module" to exactly the same extent as cutting discs, diamond cutting discs, grinding discs or conventional flap discs (which we call lamellar flap discs) which are simply suspended by their hole.



Industry

Display panel

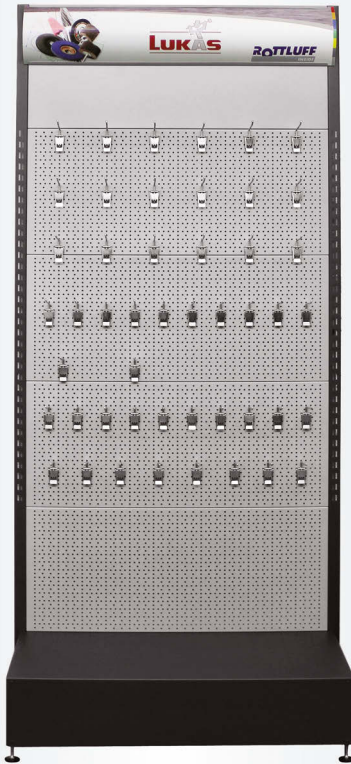

Stable self-supporting presentation stand with perforated panel

Accessories

- Hook hangers for Euro hole packaging
- Hook hangers for all products with a hole
- Suspended shelf
- Brochure pouch

Dimensions:
1 x 2,20 x 0,4 m

Product-Number:
A89403

Individual configuration



Industry

Counter display



Counter display, cardboard, for tool Ø 115 mm

Dimensions:
225 x 118 x 118/30 mm

Product-Number:
A896225118118

Counter display, cardboard, for tool Ø 125 mm

Dimensions:
225 x 128 x 128/30 mm

Product-Number:
A896225128128



Counter display, lockable

Ordering example: A5039004022



Counter display for tungsten carbide burrs
Content:

Tungsten carbide burrs, 2x each
HFA 0313.03 ZX, HFA 0820.06 ZX,
HFA 1020.06 ZX, HFA 1225.06 ZX,
HFC 0313.03 ZX, HFC 0820.06 ZX,
HFC 1020.06 ZX, HFC 1225.06 ZX,
HFD 0605.03 ZX, HFD 0807.06 ZX,
HFD 1009.06 ZX, HFD 1210.06 ZX,
HFG 0313.03 ZX, HFG 0820.06 ZX,
HFG 1020.06 ZX, HFG 1225.06 ZX,
HFM 0311.03 ZX, HFF 0820.06 ZX,
HFF 1020.06 ZX, HFF 1225.06 ZX

Dimensions:
235 x 250 x 400 mm

Product-Number:
A5039004022



BASE-X product range for retailers

Ordering example: A50010313322F

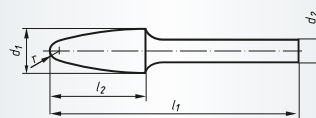

Packing unit:
5 pcs. per type

Description	Cut	Overview of shapes	similar DIN 8033	d ₁ mm	l ₂ mm	d ₂ mm	l ₁ mm	Product-Number	recommended for	
HFA 0313.03 BASE-X	ZX		ZYA 0313	3	13	3	40	A50010313322F	1 2 3 4 5 7	■
HFA 0820.06 BASE-X	ZX		ZYA 0820	8	20	6	60	A50010820622F	1 2 3 4 5 7	■
HFA 1225.06 BASE-X	ZX		ZYA 1225	12	25	6	65	A50011225622F	1 2 3 4 5 7	■
HFC 0313.03 BASE-X	ZX		WRC 0313	3	13	3	40	A50020313322F	1 2 3 4 5 7	■
HFC 0820.06 BASE-X	ZX		WRC 0820	8	20	6	60	A50020820622F	1 2 3 4 5 7	■
HFC 1225.06 BASE-X	ZX		WRC 1225	12	25	6	65	A50021225622F	1 2 3 4 5 7	■
HFD 0605.03 BASE-X	ZX		KUD 0605	6	5	3	35	A50030605322F	1 2 3 4 5 7	■
HFD 0807.06 BASE-X	ZX		KUD 0807	8	7	6	47	A50030807622F	1 2 3 4 5 7	■
HFD 1210.06 BASE-X	ZX		KUD 1210	12	10	6	51	A50031210622F	1 2 3 4 5 7	■
HFG 0313.03 BASE-X	ZX		SPG 0313	3	13	3	40	A50040313322F	1 2 3 4 5 7	■
HFG 0820.06 BASE-X	ZX		---	8	20	6	60	A50040820622F	1 2 3 4 5 7	■
HFG 1225.06 BASE-X	ZX		SPG 1225	12	25	6	65	A50041225622F	1 2 3 4 5 7	■
HFM 0311.03 BASE-X	ZX		SKM 0311	3	11	3	40	A50050311322F	1 2 3 4 5 7	■
HFF 0820.06 BASE-X	ZX		---	8	20	6	60	A50100820622F	1 2 3 4 5 7	■
HFF 1225.06 BASE-X	ZX		RBF 1225	12	25	6	65	A50101225622F	1 2 3 4 5 7	■



Industry

Mounted point assortment – STEEL

Ordering example: A20480005602



Packing unit:
1 pc. per type

Description	Shank Ø mm	Quality	Contents	1 piece each	Product-Number	recommended for	
Assortment STEEL	6	EKR	5-pieces	ZY 1632.06, EKR 46 N V4, ZY 2525.06, EKR 36 N V4, WKS 2025.06, EKR 60 N V4, KU 2525.06, EKR 36 N V4, KE 1632.06, EKR 46 N V4	A20480005602	① ② ③	■



Industry

Mounted point assortment – INOX

Ordering example: A20480004627W



Packing unit:
1 pc. per type

Description	Shank Ø mm	Quality	Contents	1 piece each	Product-Number	recommended for	
Assortment INOX	6	NK-BA	4-pieces	ZY 1332.06, NK 24 N BA Soft, ZY 2040.06, NK 24 N BA Soft, ZY2 4006.06, NK 24 N BA Soft, KU 2525.06, NK/NK 24 R BA 98	A20480004627W	② ③ ④ ⑥	■



Lamellar Flap Discs, SLTT

Ordering example: A27201150400045F



Packing unit:

20 pcs. per type
from Ø 178 = 10 pcs. per type

v_{max.}: 80 m/s

Z POWER = Abrasive cloth using Zirconia Alum. Oxide with special coating containing active grinding additives

Ceramic = Abrasive cloth ceramic grain

ZK = Abrasive cloth with Zirconia Alum. Oxide

Description	Grits	D mm	H mm	n max (1/min)	Product-Number	recommended for	
SLTT 115	Z Power 40	115	22,23	13.300	A27201150400045F	① ② ③ ④	■
SLTT 115	Ceramic 40	115	22,23	13.300	A27201150400050F	① ② ③ ④ ⑤ ⑥ ⑦ ⑧	■
SLTT 115	ZK 40	115	22,23	13.300	A27201150400065F	① ② ③ ④ ⑤ ⑥ ⑦ ⑧	■
SLTT 115	Z Power 60	115	22,23	13.300	A27201150600045F	① ② ③ ④	■
SLTT 115	Ceramic 60	115	22,23	13.300	A27201150600050F	① ② ③ ④ ⑤ ⑥ ⑦ ⑧	■
SLTT 115	ZK 60	115	22,23	13.300	A27201150600065F	① ② ③ ④ ⑤ ⑥ ⑦ ⑧	■
SLTT 125	Z Power 40	125	22,23	12.200	A27201250400045F	① ② ③ ④	■
SLTT 125	Ceramic 40	125	22,23	12.200	A27201250400050F	① ② ③ ④ ⑤ ⑥ ⑦ ⑧	■
SLTT 125	ZK 40	125	22,23	12.200	A27201250400065F	① ② ③ ④ ⑤ ⑥ ⑦ ⑧	■
SLTT 125	Z Power 60	125	22,23	12.200	A27201250600045F	① ② ③ ④	■
SLTT 125	Ceramic 60	125	22,23	12.200	A27201250600050F	① ② ③ ④ ⑤ ⑥ ⑦ ⑧	■
SLTT 125	ZK 60	125	22,23	12.200	A27201250600065F	① ② ③ ④ ⑤ ⑥ ⑦ ⑧	■
SLTT 178	Z Power 40	178	22,23	8.500	A27201780400045F	① ② ③ ④	■
SLTT 178	Ceramic 40	178	22,23	8.500	A27201780400050F	① ② ③ ④ ⑤ ⑥ ⑦ ⑧	■
SLTT 178	ZK 40	178	22,23	8.500	A27201780400065F	① ② ③ ④ ⑤ ⑥ ⑦ ⑧	■
SLTT 178	Z Power 60	178	22,23	8.500	A27201780600045F	① ② ③ ④	■
SLTT 178	Ceramic 60	178	22,23	8.500	A27201780600050F	① ② ③ ④ ⑤ ⑥ ⑦ ⑧	■
SLTT 178	ZK 60	178	22,23	8.500	A27201780600065F	① ② ③ ④ ⑤ ⑥ ⑦ ⑧	■

Please refer to page 234 for detailed information on the advantages of SLTT.



High Performance

Lamellar Flap Discs, V2 Power

Ordering example: A27441150401445F



Packing unit:
 20 pcs. per type
 from Ø 178 = 10 pcs. per type
 v_{max.}: 80 m/s
 Z POWER = Abrasive cloth using Zirconia Alum. Oxide with special coating containing active grinding additives
 Ceramic = Abrasive cloth ceramic grain
 ZK = Abrasive cloth with Zirconia Alum. Oxide

Description	Grits	D mm	H mm	n max (1/min)	Product-Number	recommended for	
V2 POWER 115	Z Power 40	115	22,23	13.300	A27441150401445F	① ② ③ ④	■
V2 POWER 115	Ceramic 40	115	22,23	13.300	A27441150401450F	① ② ③ ④ ⑤ ⑥ ⑦ ⑧	■
V2 POWER 115	ZK 40	115	22,23	13.300	A27441150401465F	① ② ③ ④ ⑤ ⑥ ⑦ ⑧	■
V2 POWER 115	Z Power 60	115	22,23	13.300	A27441150601445F	① ② ③ ④	■
V2 POWER 115	Ceramic 60	115	22,23	13.300	A27441150601450F	① ② ③ ④ ⑤ ⑥ ⑦ ⑧	■
V2 POWER 115	ZK 60	115	22,23	13.300	A27441150601465F	① ② ③ ④ ⑤ ⑥ ⑦ ⑧	■
V2 POWER 125	Z Power 40	125	22,23	12.200	A27441250401445F	① ② ③ ④	■
V2 POWER 125	Ceramic 40	125	22,23	12.200	A27441250401450F	① ② ③ ④ ⑤ ⑥ ⑦ ⑧	■
V2 POWER 125	ZK 40	125	22,23	12.200	A27441250401465F	① ② ③ ④ ⑤ ⑥ ⑦ ⑧	■
V2 POWER 125	Z Power 60	125	22,23	12.200	A27441250601445F	① ② ③ ④	■
V2 POWER 125	Ceramic 60	125	22,23	12.200	A27441250601450F	① ② ③ ④ ⑤ ⑥ ⑦ ⑧	■
V2 POWER 125	ZK 60	125	22,23	12.200	A27441250601465F	① ② ③ ④ ⑤ ⑥ ⑦ ⑧	■
V2 POWER 178	Z Power 40	178	22,23	8.500	A27441780401445F	① ② ③ ④	■
V2 POWER 178	Ceramic 40	178	22,23	8.500	A27441780401450F	① ② ③ ④ ⑤ ⑥ ⑦ ⑧	■
V2 POWER 178	ZK 40	178	22,23	8.500	A27441780401465F	① ② ③ ④ ⑤ ⑥ ⑦ ⑧	■
V2 POWER 178	Z Power 60	178	22,23	8.500	A27441780601445F	① ② ③ ④	■
V2 POWER 178	Ceramic 60	178	22,23	8.500	A27441780601450F	① ② ③ ④ ⑤ ⑥ ⑦ ⑧	■
V2 POWER 178	ZK 60	178	22,23	8.500	A27441780601465F	① ② ③ ④ ⑤ ⑥ ⑦ ⑧	■

Please refer to page 238 for detailed information on the advantages of V2 Power.



High Performance

Lamellar Flap Discs, V3 Control

Ordering example: A27451150401411F



Packing unit:
 8 pcs. per type
 from Ø 125 = 16 pcs. per type
 v_{max.}: 80 m/s
 ZK = Abrasive cloth with Zirconia Alum. Oxide

Description	Grits	D mm	H mm	n max (1/min)	Product-Number	recommended for	
V3 CONTROL 115	ZK 40	115	22,23	13.300	A27451150401411F	① ② ③ ④ ⑤ ⑥ ⑦	■
V3 CONTROL 115	ZK 60	115	22,23	13.300	A27451150601411F	① ② ③ ④ ⑤ ⑥ ⑦	■
V3 CONTROL 125	ZK 40	125	22,23	12.200	A27451250401411F	① ② ③ ④ ⑤ ⑥ ⑦	■
V3 CONTROL 125	ZK 60	125	22,23	12.200	A27451250601411F	① ② ③ ④ ⑤ ⑥ ⑦	■

Please refer to page 242 for detailed information on the advantages of V3 Control.



Lamellar Flap Discs, V4 Master

Ordering example: A27471250401465F



Packing unit:
20 pcs. per type
 v_{max} : 80 m/s
ZK = Abrasive cloth with Zirconia Alum. Oxide

Description	Grits	D mm	H mm	n max (1/min)	Product-Number	recommended for	
V4 MASTER 125	ZK 40	125	22,23	12.200	A27471250401465F	1 2 3 4 5 6 7	■
V4 MASTER 125	ZK 60	125	22,23	12.200	A27471250601465F	1 2 3 4 5 6 7	■

Please refer to page 244 for detailed information on the advantages of V4 Master.



Lamellar Flap Discs, SLTflex

Ordering example: A272711504018F



Packing unit:
20 pcs. per type
 v_{max} : 80 m/s
ZKS = Zirconia Alum. Oxide with special coating containing active grinding additives

Description	Grits	D mm	H mm	n max (1/min)	Product-Number	recommended for	
SLTflex 115	ZKS 40	115	22,23	13.300	A272711504018F	1 2 3 4 5 6 7	■
SLTflex 115	ZKS 60	115	22,23	13.300	A272711506018F	1 2 3 4 5 6 7	■
SLTflex 125	ZKS 40	125	22,23	12.200	A272712504018F	1 2 3 4 5 6 7	■
SLTflex 125	ZKS 60	125	22,23	12.200	A272712506018F	1 2 3 4 5 6 7	■

Please refer to page 246 for detailed information on the advantages of SLTflex.



Industry

Mounted flap wheels of abrasive cloth

Ordering example: A2200030103060F

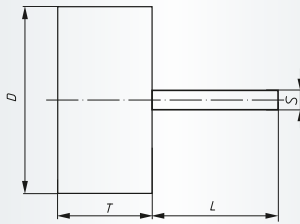

Packing unit:
10 pcs. per type
NK = reg. Aluminium Oxide

Description	Grits	D mm	T mm	S mm	L mm	n recom. (1/min)	n max. (1/min)	Product-Number	recommended for	
SFL 03010.03	NK 60	30	10	3	40	16.000	18.000	A2200030103060F	① ② ③ ④ ⑤ ⑥ ⑦ ⑧	■
SFL 03010.03	NK 80	30	10	3	40	16.000	18.000	A2200030103080F	① ② ③ ④ ⑤ ⑥ ⑦ ⑧	■
SFL 03010.03	NK 120	30	10	3	40	16.000	18.000	A2200030103120F	① ② ③ ④ ⑤ ⑥ ⑦ ⑧	■
SFL 04020.06	NK 60	40	20	6	40	12.000	18.000	A2200040206060F	① ② ③ ④ ⑤ ⑥ ⑦ ⑧	■
SFL 04020.06	NK 80	40	20	6	40	12.000	18.000	A2200040206080F	① ② ③ ④ ⑤ ⑥ ⑦ ⑧	■
SFL 04020.06	NK 120	40	20	6	40	12.000	18.000	A2200040206120F	① ② ③ ④ ⑤ ⑥ ⑦ ⑧	■
SFL 06030.06	NK 40	60	30	6	40	8.000	12.000	A2200060306040F	① ② ③ ④ ⑤ ⑥ ⑦ ⑧	■
SFL 06030.06	NK 60	60	30	6	40	8.000	12.000	A2200060306060F	① ② ③ ④ ⑤ ⑥ ⑦ ⑧	■
SFL 06030.06	NK 80	60	30	6	40	8.000	12.000	A2200060306080F	① ② ③ ④ ⑤ ⑥ ⑦ ⑧	■
SFL 06030.06	NK 120	60	30	6	40	8.000	12.000	A2200060306120F	① ② ③ ④ ⑤ ⑥ ⑦ ⑧	■



Industry

Mounted flap wheels of abrasive fleece

Ordering example: A2203040206104F

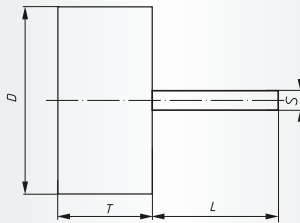

Packing unit:
10 pcs. per type
A = reg. Aluminium Oxide

Description	Grits	D mm	T mm	S mm	L mm	n recom. (1/min)	n max. (1/min)	Product-Number	recommended for	
SFV 04020.06	A 104	40	20	6	40	7.500	14.000	A2203040206104F	① ② ③ ④ ⑤ ⑥ ⑦ ⑧	■
SFV 04020.06	A 106	40	20	6	40	7.500	14.000	A2203040206106F	① ② ③ ④ ⑤ ⑥ ⑦ ⑧	■
SFV 06030.06	A 104	60	30	6	40	5.000	9.000	A2203060306104F	① ② ③ ④ ⑤ ⑥ ⑦ ⑧	■
SFV 06030.06	A 106	60	30	6	40	5.000	9.000	A2203060306106F	① ② ③ ④ ⑤ ⑥ ⑦ ⑧	■



Flap wheels of abrasive fleece with abrasive cloth

Ordering example: A2204040206104F

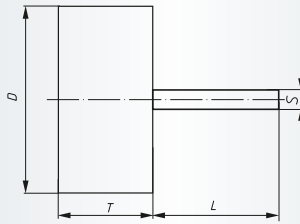

Packing unit:

10 pcs. per type

A = reg. Aluminium Oxide

Description	Grits	D mm	T mm	S mm	L mm	n recom. (1/min)	n max. (1/min)	Product-Number	recommended for
SFM 04020.06	A 104/80	40	20	6	40	7.500	14.000	A2204040206104F	1 2 3 4 5 6 7 8
SFM 04020.06	A 106/150	40	20	6	40	7.500	14.000	A2204040206106F	1 2 3 4 5 6 7 8
SFM 06030.06	A 104/80	60	30	6	40	5.000	9.000	A2204060306104F	1 2 3 4 5 6 7 8
SFM 06030.06	A 106/150	60	30	6	40	5.000	9.000	A2204060306106F	1 2 3 4 5 6 7 8



Cutting discs BASE-X for stainless steel and metal

Ordering example: A3890101150122002

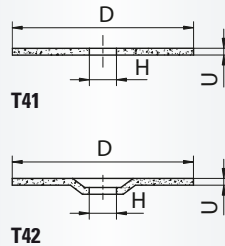

Packing unit:

see page 183

T41 = flat

T42 = depressed centre

Iron, sulphur and chlorine < 0,1%

v_{max}: 80 m/s

Description	Quality	Ø D mm	Thickness U mm	Bore H mm	n max. (1/min)	Product-Number	recommended for
T41 BASE-X	A60T-BF INOX	115	1,0	22,23	13.300	A3890101150122002	1 2 3 4 5 6 7
T41 BASE-X	A60T-BF	115	1,0	22,23	13.300	A3890101150122001	1 2 3 5
T41 BASE-X	A30R-BF	115	3,0	22,23	13.300	A3890101150322002	1 2 3 5
T42 BASE-X	A30R-BF	115	3,0	22,23	13.300	A3890101150322001	1 2 3 5
T41 BASE-X	A60T-BF INOX	125	1,0	22,23	12.200	A3890101250122002	1 2 3 4 5 6 7
T41 BASE-X	A60T-BF	125	1,0	22,23	12.200	A3890101250122001	1 2 3 5
T41 BASE-X	A30R-BF	125	3,0	22,23	12.200	A3890101250322002	1 2 3 5
T42 BASE-X	A30R-BF	125	3,0	22,23	12.200	A3890101250322001	1 2 3 5
T41 BASE-X	A30R-BF	180	3,0	22,23	8.500	A3890101800322002	1 2 3 5
T42 BASE-X	A30R-BF	180	3,0	22,23	8.500	A3890101800322001	1 2 3 5
T41 BASE-X	A46T-BF INOX	230	1,8	22,23	6.600	A3890102300122002	1 2 3 4 5 6 7
T41 BASE-X	A30R-BF	230	3,0	22,23	6.600	A3890102300322002	1 2 3 5
T42 BASE-X	A30R-BF	230	3,0	22,23	6.600	A3890102300322001	1 2 3 5

Grinding discs BASE-X for machining steel

Ordering example: A3891101150622001

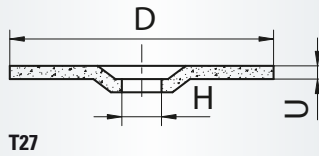

Packing unit:
see page 199
T27 = depressed centre
Iron, sulphur and chlorine < 0,1%
 v_{max} : 80 m/s

Description	Quality	Ø D mm	Thickness U mm	Bore H mm	n max. (1/min)	Product-Number	recommended for	
T27 BASE-X	A24R-BF	115	6,0	22,23	13.300	A3891101150622001	1 2 3	■
T27 BASE-X	A24R-BF	125	6,0	22,23	12.200	A3891101250622001	1 2 3	■
T27 BASE-X	A24R-BF	180	6,0	22,23	8.500	A3891101800622001	1 2 3	■
T27 BASE-X	A24R-BF	230	6,0	22,23	6.500	A3891102300622001	1 2 3	■

Diamond cutting discs BASE-X, laser welded

Ordering example: A345231251207105

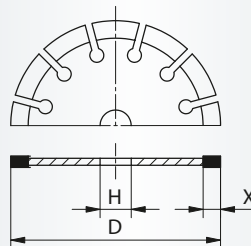

Packing unit:
1 pc.
 v_{max} : 80 m/s
Laser welded

Description	Quality	D mm	Height of segments X mm	H mm	n max. (1/min)	Product-Number	recommended for	
BASE-X	Blue Cut S10	115	10	22,23	13.300	A345241151110085	10 11	■
BASE-X	BG-L	125	7	22,23	12.200	A345231251207105	11 14	■
BASE-X	Blue Cut S10	125	10	22,23	12.200	A345241251110095	10 11	■
BASE-X	BG-L	230	7	22,23	6.600	A345232301207165	11 14	■
BASE-X	Blue Cut S10	230	10	22,23	6.600	A345242301110165	10 11	■

Please see page 211–224 for further products.



Industry

Arbors for Felt Polishing Wheels

Ordering example: A1630780

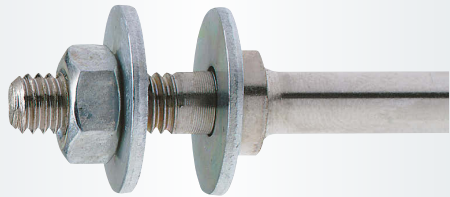
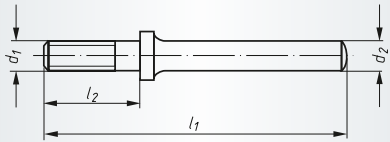
Packing unit:
5 pcs. per type

The delivery includes for each stud

- 2 washers Ø 18 mm
- 2 washers Ø 30 mm
- 1 hex nut

Description	d ₁ mm	l ₂ mm	d ₂ mm	l ₁ mm	n max. (1/min)	Product-Number												
ASB 780	M6	20	6	63	7.000	A1630780												■
ASB 781	M6	30	6	73	7.000	A1630781												■



Industry

Arbors for tools with internal thread

Ordering example: A16303422

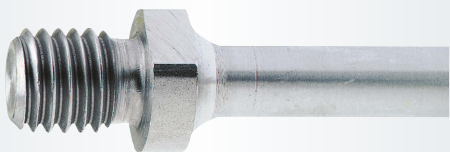
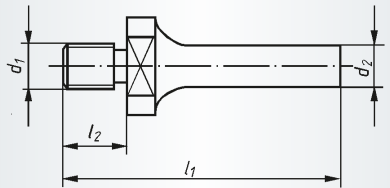
Packing unit:
5 pcs. per type

Description	d ₁ mm	l ₂ mm	d ₂ mm	l ₁ mm	Product-Number													
ASB 342 B	M 10	12	6	52	A16303422													■
ASB 342 C	M 12	14	6	54	A16303423													■
ASB 342 D	M 8	10	6	50	A16303424													■
ASB 344 B	M 10	12	8	52	A16303442													■
ASB 344 C	M 12	14	8	54	A16303443													■
ASB 345 B	M 10	12	10	52	A16303452													■



Industry

Mounting arbors for small cutting-off wheels

Ordering example: A36600060604

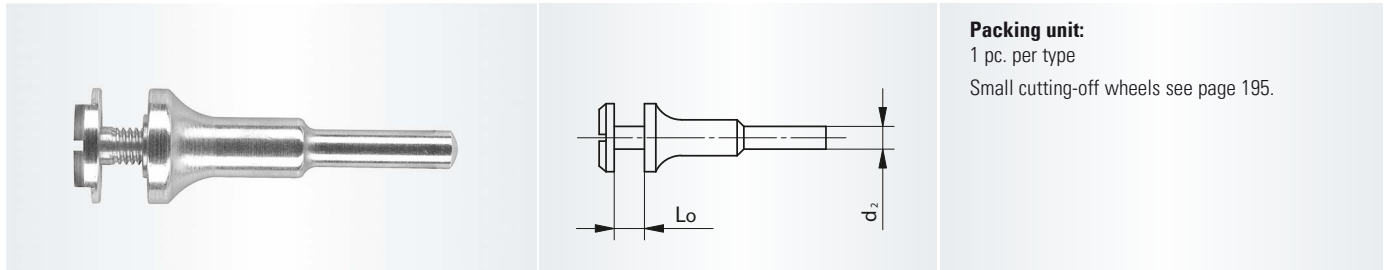

Packing unit:
1 pc. per type
Small cutting-off wheels see page 195.

Description	Tools' internal diameter mm	L ₀	d ₂ mm	Product-Number																		
ASB 6/6	6	0-4	6	A36600060604																	■	
ASB 6/10	10	0-4	6	A36600061004																		■
ASB 8/10	10	4-8	8	A36600081048																		■



Industry

Mounting system for polishing wheels

Ordering example: A6981008000



Packing unit:
1 pc. per type

Description	Product-Number	recommended for																				
Mounting system MCA + K25	A6981008000																					■

The mounting system for polishing wheels consists of a plastic sleeve (MCA) and a mounting arbor with 8 mm diameter shaft (K25) which is solely applicable to shape SE1 in the dimensions 10010 B 25 and 10020 B 25. It is not permitted to use this

mounting system for polishing wheels with larger diameters. Maximum peripheral wheel speed using this mounting method is 10m/s; this means a maximum spindle speed of 1900 R.P.M. with a wheel diameter of 100 mm.



Industry

Handstones

Ordering example: A204300000118

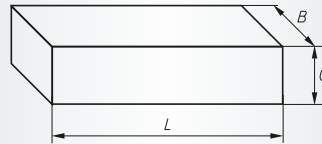

Packing unit:

5 pcs. per type

Further dimensions (see table below) and qualities on request.

Description	Quality	L mm	B mm	C mm	Product-Number	recommended for															
RU 1	SICGR 60 O V23/green = fine	50	25	15	A204300000118															9	■
RU 1	SICDKL 24 O V23/dark=coarse	50	25	15	A204300000122															9	■
RU 2	SICGR 60 O V23/green = fine	100	30	15	A204300000218															9	■
RU 2	SICDKL 24 O V23/dark=coarse	100	30	15	A204300000222															9	■
RU 3	SICGR 60 O V23/green = fine	100	50	25	A204300000318															9	■
RU 3	SICDKL 24 O V23/dark=coarse	100	50	25	A204300000322															9	■
RU 4	SICGR 60 O V23/green = fine	150	50	25	A204300000418															9	■
RU 4	SICDKL 24 O V23/dark=coarse	150	50	25	A204300000422															9	■
RU 5	EKW 100 E (9) V40	150	25	16,5	A2043150251608															3	■
RU 6	EKW 100 E (9) V40	200	50	25	A2043200502508															3	■

RU 1-4 is particularly suitable for

- profiling
 - sharpening
 - opening of pores
 - dressing
- of bonded grinding and polishing tools.

Available dimensions for handstones

Shape	length mm	width mm	height mm
	25	15	5 to 30
	44	35	18 to 30
	48	19	5 to 30
	50	25	10 to 35
	90	70	20 to 35
	100	30	10 to 35
	100	50	10 to 35
	120	10	5 to 35
	150	25	10 to 35
	150	50	10 to 35
	200	50	10 to 35
	216	78	20 to 35
	150	13	5 to 35



Tool-sets Tungsten Carbide Burrs, cut 7, shank 3 mm

Ordering example: A10390010



Packing unit:
1 pc. per type

Description	Shank Ø mm	Cut mm	Contents	1 piece each	Product-Number	recommended for	
F10 S3	3	Z7	10-pieces	HFA 0313, HFA 0613, HFC 0313, HFC 0613, HFD 0302, HFD 0605, HFG 0313, HFG 0613, HFM 0613, HFF 0313	A10390010	<input checked="" type="checkbox"/> 1 <input checked="" type="checkbox"/> 2 <input checked="" type="checkbox"/> 3 <input checked="" type="checkbox"/> 5 <input checked="" type="checkbox"/> 7	■



Tool-sets Tungsten Carbide Burrs, cut 7, shank 6 mm

Ordering example: A1039001006



Packing unit:
1 pc. per type

Description	Shank Ø mm	Cut mm	Contents	1 piece each	Product-Number	recommended for	
F10 S6	6	Z7	10-pieces	HFAS 0616, HFAS 1225, HFC 0616, HFC 1225, HFD 0605, HFD 1210, HFG 0618, HFG 1225, HFF 0820, HFF 1225	A1039001006	<input checked="" type="checkbox"/> 1 <input checked="" type="checkbox"/> 2 <input checked="" type="checkbox"/> 3 <input checked="" type="checkbox"/> 5 <input checked="" type="checkbox"/> 7	■



Base

Tool-set, BASE-X, F5 S3

Ordering example: A10390053



Packing unit:
1 pc. per type

Description	Shank Ø mm	Cut mm	Contents	1 piece each	Product-Number	recommended for	
F5 S3 BASE-X	3	ZX	5-pieces	HFA 0313, HFC 0313, HFD 0605, HFF 0313, HFG 0313	A10390053	1 2 3 4 5 7	■



Base

Tool-set, BASE-X, F5 S6

Ordering example: A10390056



Packing unit:
1 pc. per type

Description	Shank Ø mm	Cut mm	Contents	1 piece each	Product-Number	recommended for	
F5 S6 BASE-X	6	ZX	5-pieces	HFA 1225, HFC 1225, HFD 1210, HFF 1225, HFG 1225	A10390056	1 2 3 4 5 7	■



Tool-sets Burrs of HSS, cut 5, shank 3 mm

Ordering example: A1239000110



Packing unit:
1 pc. per type

Description	Shank Ø mm	Cut	Contents	1 piece each	Product-Number	recommended for	
F1	3	Z5	10-pieces	MF 807, MF 813, MF 841, MF 845, MF 850, MF 853, MF 864, MF 866, MF 872, MF 874	A1239000110	① ② ⑥	■



Tool-sets Burrs of HSS, cut 3, shank 6 mm

Ordering example: A123900003



Packing unit:
1 pc. per type

Description	Shank Ø mm	Cut	Contents	1 piece each	Product-Number	recommended for	
F3	6	Z3	10-pieces	MFA 0616, MFA 1225, MFC 1225, MFD 0403, MFD 1210, MFE 1220, MFG 1230, MFH 1230, MFK 0620, MFM 0618	A123900003	① ② ⑥	■



Industry

Tool-sets Burrs of HSS, cut 3 and cut 5, shank 6 mm

Ordering example: A12390004



Packing unit:
1 pc. per type

Description	Shank Ø mm	Cut	Contents	1 piece each	Product-Number	recommended for	
F4	6	Z3/Z5	20-pieces	Z3 MFA 0616, MFA 1013, MFA 1225, MFC 1225, MFD 0807, MFD 1210, MFE 1220, MFE 1625, MFG 1220, MFG 1230, MFK 1230, MFL 1630, MFM 0618, MFM 1230, MFN 1213, MFN 1230 Z5 MFA 0304, MFA 0607, MFN 0303, MFN 0606	A12390004	① ② ③ ④ ⑤ ⑥ ⑦ ⑧ ⑨ ⑩ ⑪ ⑫ ⑬ ⑭ ⑮ ⑯ ⑰ ⑱ ⑲	■



Industry

Assortment, Polishing points, group P1

Ordering example: A2600114



Packing unit:
1 pc. per type
v_{max.}: 50 m/s

Description	Contents	1 piece each	Product-Number	recommended for	
Assortment 114	14-pieces	P1ZY 0408.03; P1ZY 0510.03; P1ZY 0610.03; P1ZY 0710.03; P1ZY 0810.03; P1ZY 1010.03; P1ZY 1013.03; P1ZY 1016.03; P1ZY 1303.03; P1ZY 1313.03; P1ZY 1316.03; P1ZY 1604.03; P1ZY 1616.03; P1ZY 2006.03	A2600114	① ② ③ ④ ⑤ ⑥ ⑦ ⑧ ⑨ ⑩ ⑪ ⑫ ⑬ ⑭ ⑮ ⑯ ⑰ ⑱ ⑲	■



Mounted points-Assortments, Quality NDW

Ordering example: A20100000353

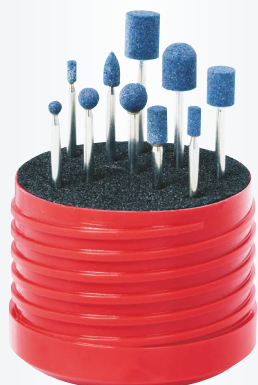

Packing unit:
1 pc. per type

Description	Shank Ø mm	Quality	Contents	1 piece each	Product-Number	recommended for	
Assortment 10	3 x 50	NDW	10-pieces	ZY 0408, ZY 0610, ZY 0810, ZY 1013, SP 0510, SP 0810, KU 0404, KU 0606, KU 0808, WR 1013	A20100000353	② ③	■



Mounted points-Assortments, Quality EKR

Ordering example: A204700001402

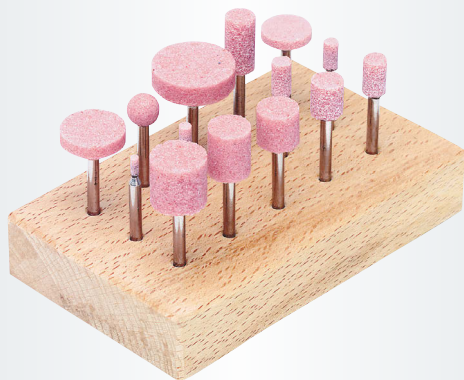

Packing unit:
1 pc. per type

Description	Shank Ø mm	Quality	Contents	1 piece each	Product-Number	recommended for	
Assortment 14	3	EKR	14-pieces	ZY 0205, ZY 0306, ZY 0408, ZY 0510, ZY 0610, ZY 0810, ZY 0816, ZY 1010, ZY 1013, ZY 1313, KU 0808, ZY 1303, ZY 1604, ZY 2006	A204700001402	① ② ③	■



Industry

Mounted points-Assortments, Quality EKR

Ordering example: A204800003602

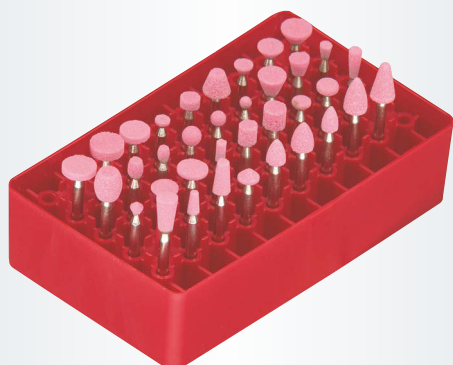

Packing unit:
1 pc. per type

Description	Shank Ø mm	Quality	Contents	1 piece each	Product-Number	recommended for	
Assortment 36	3	EKR	36-pieces	D1, D2, D3, D4, D5, D6, D7, D8, D9, D10, D11, D12, D13, D14, D15, D16, D17, D18, D19, D20, D21, D22, D23, D24, D25, D26, D27, D28, D29, D30, D31, D32, D33, D34, D35, D36	A204800003602	① ② ③	■



Industry

Mounted points-Assortments, Quality EKBR

Ordering example: A204800003611

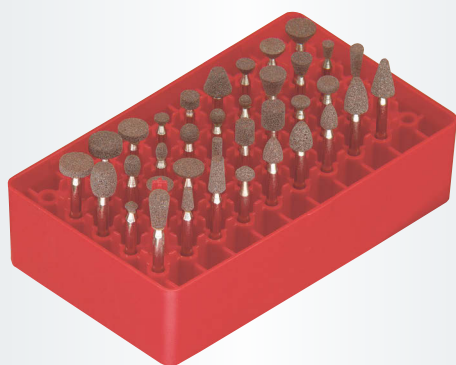

Packing unit:
1 pc. per type

Description	Shank Ø mm	Quality	Contents	1 piece each	Product-Number	recommended for	
Assortment 36	3	EKBR	36-pieces	D1, D2, D3, D4, D5, D6, D7, D8, D9, D10, D11, D12, D13, D14, D15, D16, D17, D18, D19, D20, D21, D22, D23, D24, D25, D26, D27, D28, D29, D30, D31, D32, D33, D34, D35, D36	A204800003611	② ③	■



Mounted points-Assortments, Quality EKR

Ordering example: A204600000202

Packing unit:
1 pc. per type



Description	Shank Ø mm	Quality	Contents	1 piece each	Product-Number	recommended for	
Assortment 45	6	EKR	45-pieces	ZY 0306, ZY 0510, ZY 0408, ZY 0610, ZY 0810, ZY 0816, ZY 1010, ZY 1020, ZY 1032, ZY2 1303, ZY 1313, ZY 1320, ZY2 1604, ZY 1616, ZY 1620, ZY 1632, ZY2 2006, ZY 2020, ZY 2025, ZY 2032, ZY 2040, ZY2 2506, ZY2 2510, ZY 2520, ZY 2525, ZY 2532, ZY2 3208, ZY 3220, ZY 3232, ZY2 4010, ZY 4020, SP 0816, SP 1020, SP 1320, SP 2032, KE 1632, KE 1640, KE 2032, KE 2040, KU 1010, KU 1313, KU 1616, KU 2020, KU 2525, KU 3232	A204600000202	① ② ③	■



Mounted caps-Assortments

Ordering example: A210000065



Packing unit:

1 pc. per type

Assortment containing:

640 pcs. Abrasive Caps

23 pcs. Mandrels

Outside dimension of box: 272 x 189 x 46 mm

NK = regular Aluminium Oxide

Description	piece	Contents	Product-Number	recommended for	
WS 65	50 pcs. 100 pcs. of 50 pcs. of 20 pcs. of 10 pcs.	Abrasive Caps, grit NK 150 SKKE 0515 SKZY 0510, SKWR 0511, SKWK 0511 SKZY 0712, SKWR 0713, SKWK 0713 SKZY 1015, SKWR 1015 SKKE 1125	A210000065	① ② ③ ④ ⑤ ⑥ ⑦ ⑧	■
	20 pcs. 10 pcs. of 15 pcs. of	Abrasive Caps, grit NK 80 SKWK 1015 SKZY 1317, SKWR 1319, SKWK 1319, SKKE 1632 SKWK 1626, SKWR 1626			
	2 pcs. of 1 pc. of	Mandrels, Shank 3 mm GTZY 0510, GTWR 0511, GTWK 0511, GTZY 0712, GTWR 0713, GTWK 0713 GTZY 1015, GTWR 1015, GTWK 1015, GTZY 1317, GTWR 1319, GTWK 1319			
	1 pc. of	Mandrels, Shank 6 mm GTKE 0515, GTKE 1125, GTWK 1626, GTWR 1626, GTKE 1632			
WS 65 Z	je 2 pcs. 1 pc. of 1 pc. of	Abrasive Caps, see WS 65 Mandrels, Shank 1/8 inch GTZY 0510, GTWR 0511, GTWK 0511, GTZY 0712, GTWR 0713, GTWK 0713 GTZY 1015, GTWR 1015, GTWK 1015, GTZY 1317, GTWR 1319, GTWK 1319 Mandrels, Shank 1/4 inch GTKE 0515, GTKE 1125, GTWK 1626, GTWR 1626, GTKE 1632	A210000065Z	① ② ③ ④ ⑤ ⑥ ⑦ ⑧	■



Safety glasses, UVEX i-vo

Ordering example: A364110

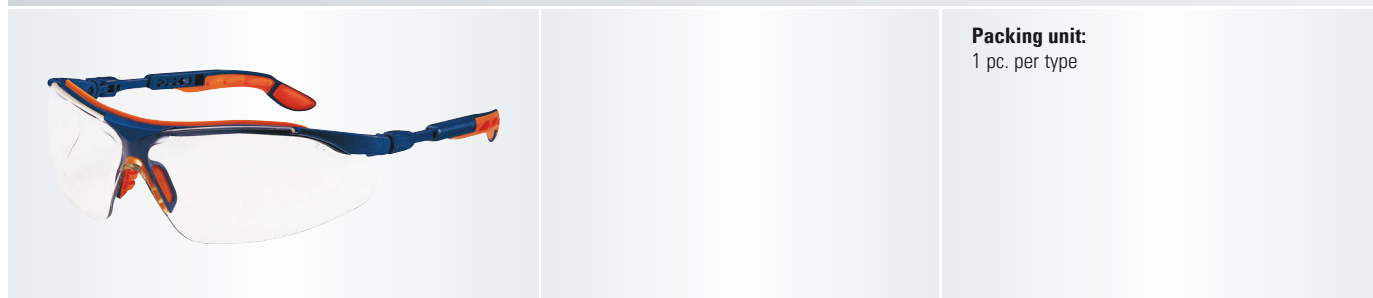

Packing unit:
1 pc. per type

Description	Product-Number											
UVEX i-vo	A364110											■

This UVEX-safety glasses provide you an optimum protection and because of the unique two-component technology they are very comfortably to wear.



Safety gloves, UVEX TOP GRADE

Ordering example: A364310

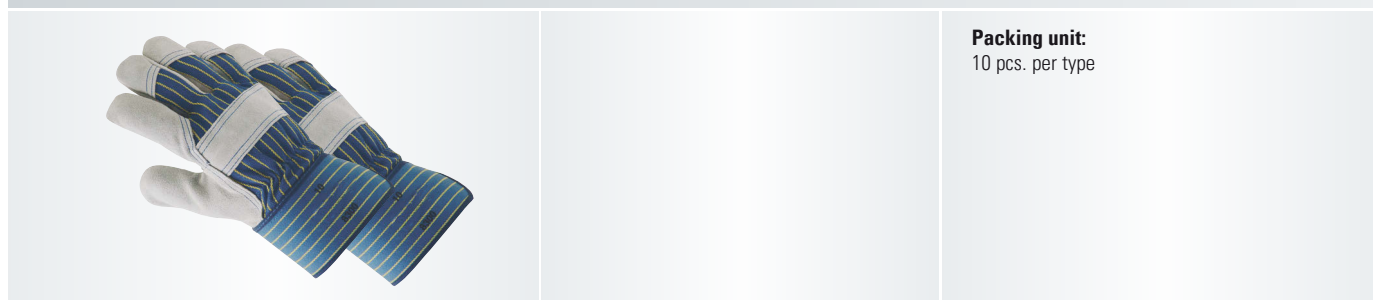

Packing unit:
10 pcs. per type

Description	Size	Product-Number											
UVEX TOP GRADE	10	A364310											■

Split-leather safety glove with high wearing comfort

Characteristics:

- Cut resistance, soft, supple leather
- Index finger, fingertips, knuckle trim and thumb



Industry

Banded ear plugs, MOLDEX Jazz-Band

Ordering example: A364410



Packing unit:
1 pc. per type

Description

Product-Number

MOLDEX Jazz-Band

A364410

Comfortable and high quality banded ear plug from MOLDEX ideal for various noise levels. The package includes a set of ear plugs on a string and two spare foam ear plugs.



Industry

Spare banded ear plugs, MOLDEX Jazz-Band

Ordering example: A364411



Packing unit:
25 pcs. per set

Description

Product-Number

MOLDEX Jazz-Band E

A364411

Comfortable foam ear plugs for change

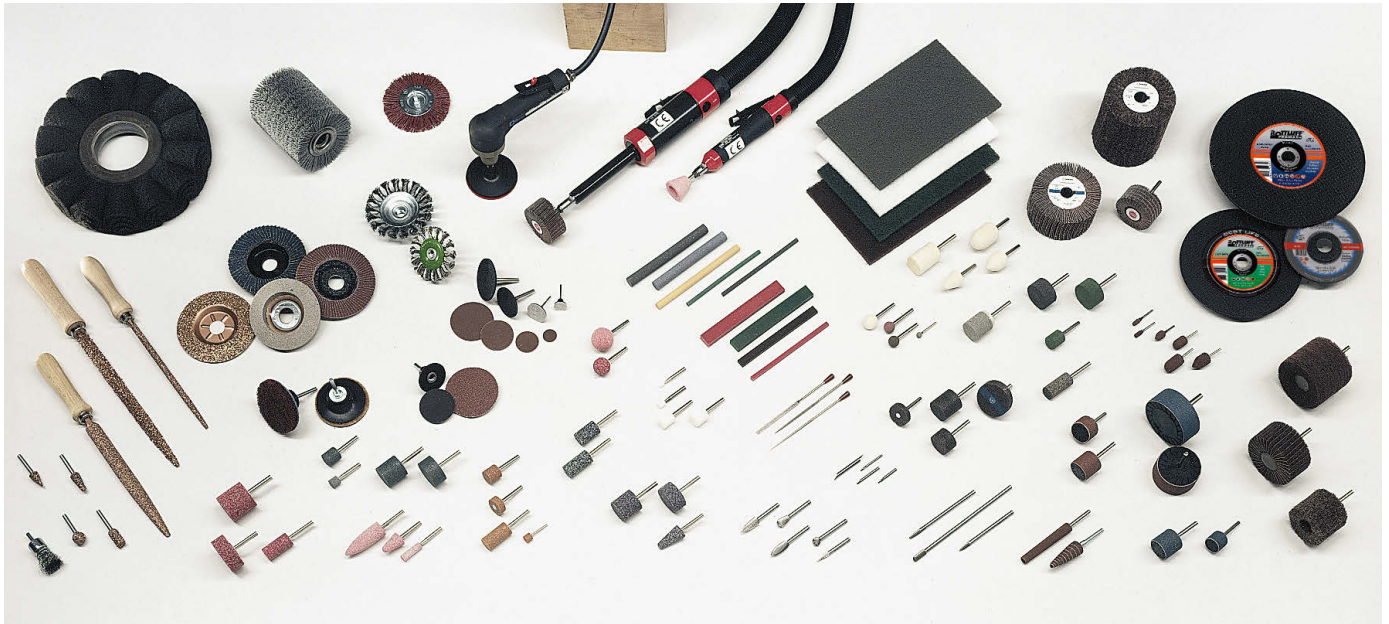
Index

A

Abrasive and diamond pastes	149
Abrasive Bands and Mandrels	301–311
cylindrical	301–309
conical shape	311
for grinding rolls	312
Abrasive Caps	321–330
cylindrical shape	321
cylindrical round nose	323–324
cylindrical pointed nose	325–326
conical round nose	327
conical shape	329
Abrasive caps-Assortments	330
Abrasive Discs	334–348
quick-change	334–339
quick-change with plastic thread	341–343
self-adhesive	344–345
self-fixing	346–348
Abrasive Rolls and Mandrels	317–318
Accessories	410–413
Mounting arbors for small cutting-off wheels	411
Mounting system for polishing wheels	411
Adapter	412
Reducing bush	412
Handstones	413
Adaptor for SFI	271
Adaptor for SFA	272
Air Tools	381–398

Arbors

for felt polishing wheels	147
for tools with internal thread	410
Mounting arbors for small cutting-off wheels	411
AS-cleaning fleece	359–362
Mounting arbor for AS-cleaning fleece	361
Assortment of small polishing points	161

B

Backing Pad for fibre discs	355
Bands and Rolls / Caps and Sleeves	322–329
cylindrical shape	322
cylindrical round nose	324
cylindrical pointed nose	326
conical round nose	328
conical shape	329
Belt grinder	384
Big Cutting discs (greater than 230 mm)	190–191
Brushes	167–173
Burrs of HSS	63–82
Cylindrical	68–69
Cylindrical round nose	70
Spherical	70–71
Oval	71
Arch pointed nose	72
Flame	73
Club	73
Round nose	74
Pointed nose	74
Inverted	75
Burrs with internal thread	79–80

C	
CBN- and diamond tools for precision machining	363–379
CBN-Points electro-plated	373–379
CBN-Points vitrified bonded	367–371
Cleaning Fleece	359–362
Conditioning Machine	398
Cup wheels for angle grinders	201–203
Cutting Discs	175–192
for stainless steel	184–185, 190, 192
for metal	186–188, 190–191
for non-ferrous metal	188
for stone, concrete and cast iron	189, 191–192
Cylindrical multiple concave burr	75
D	
Diamond Cup Wheels	217–219
Diamond Cutting Discs	208–217
Diamond Files electro plated	377–379
Diamond Paste	149
Diamond-Points, electro-plated	374–376
Diamond-Points, vitrified bonded	370–371
Diamondtools	205–219
Diamond Sprays	150
Disc Carriers	339–348
quick-change	339
quick-change with plastic thread	343
for self-adhesive abrasive discs	345
for self-fixing abrasive discs	346, 348
E	
Economy Rolls	356
Electric power tool	398
Engraving Cutters	87–92
of solid carbide	90
of HSS	91
of solid carbide	92
F	
Felt Polishing Points, group P3	144–146
Felt polishing wheels	147
Fibre Discs	351–353
Filing Discs in WS	84–85
Filing Rings in WS	86
Flap Rolls	297–300
of abrasive cloth	297
of abrasive fleece	298
of abrasive fleece for conditioning machines	300
abrasive fleece/abrasive cloth combination	299–300
Flap wheels	261–273
Slotted flap wheels	261
Flap wheels – recessed	268
Flap wheels of abrasive cloth	
regular aluminium oxide, special bond	269
Flap wheels of abrasive cloth, silicon carbide	270
Flap wheels of abrasive cloth, with internal thread	271
Flap wheels of abrasive cloth, with external thread	272
Mini-Flap wheels of abrasive cloth	273
Flap wheels of fleece flaps	277–279
Flap wheels of abrasive fleece	
with abrasive cloth	281–283
Flap Wheels	287–292
of abrasive cloth	287–288
of abrasive fleece	288–291
abrasive fleece/abrasive cloth combination	291–292
Fleece Mops of Abrasive Fleece	297
Fleece Pads	358
Fleece Rolls	358
Free-hand cutting disc for angle grinders	184–189
G	
Grinding Discs	193–200
for stainless steel	195–197
for metal	197–198, 200
for non-ferrous metals	199
for cast iron	199
for stone and cast iron	200
H	
Handstones	124
Health and safety equipment	424–425
Safety glasses	424
Safety gloves	424
Banded ear plugs	425
Spare banded ear plugs	425
L	
Lamellar Flap Discs	236–257
The SLTT	236–237
The V2 POWER	240–241
The V3 Control	243
The V4 Master	245
The SLTflex	247–248
SLTO/SLTR on fibre backing	249–252
SLTZ with grinding additives	253
SLTS with vertical Flaps	253
SLTB/SLTF on steel backing	254
SLTK on plastic backing	255
SLTC, SLTM, SLTV NAWAROFLEX	256–257
SLTP for finishing an polishing	257
Linishing belts	313

M

Mandrels	309–312
cylindrical	309–311
conical shape	312
Mandrels	318
Marbling points group P6	159
Miniature Burrs	76–78
Mounted Flap Wheels of abrasive Cloth	261–273
Mounted Flap Wheels of abrasive Fleece	277–283
Mounted fleece discs	280
Mounted Points	93–131
Qualities and areas of application	94–97
Cylinder	106–113
Cylindrical pointed nose	113
Pointed nose	113–114
Spherical	115–116
Conical round nose	117–118
Cylindrical round nose	115
American shapes A	118–119
American shapes B	120
Miniatur-Mounted points	120–123
Handstones	124
Points-Assortments	125–128
Mounted points special for your particular application	130–131
Mounting system for polishing wheels	158
Mounting device for grinding rolls	312

N

NAWAROFLEX, Flap Discs	256–257
------------------------	---------

P

Pneumatic Air Tools	383–397
Polishing Points	133–161
group P1	137–139
group P2	140–143
group P3	144–147
Felt polishing wheels	147
Arbors for felt polishing wheels	147
Abrasive and diamond pastes, diamond sprays and thinners	148–150
group P4	151–152
group P5	153–154
group P6	155–160
Mounting system for polishing wheels	158
Conditioning machine	160
group P7	161
Polishing rolls	160

R

Rasp burrs	57
Reducing bushes	412
Rolls manufactured	293
Rotary files	58

S

Sheets of abrasive cloth	357
Small polishing points group P7	161
Small cutting discs (less than 100 mm)	192
Straight Grinder	385–397
Summary of available shapes	99

T

Technical Brushes	167–173
Cylindrical brush with shank	169
Cylindrical brush of abrasive nylon	169
Conical brushes	170
End brush with shank	170
pipe brush	171
pipe brush of abrasive nylon	171
Wheel brush	172
Twist knot wheel brush	172
Cup brush, with thread	173
Hand brush	173
Thinner for diamond pastes	150
Tool-sets	414–423
Tungsten Carbide Burrs	25–62
Cylindrical	32–34
Cylindrical round nose	35–36
Spherical	37–38
Oval	39
Arch round nose	40–41
Arch pointed nose	41–42
Flame	43
Internal	43
Pointed nose	44
Conical round nose	44–45
Conical pointed nose	46
Inverted cone	47
Burrs for machining plastics	48
Engraving Cutters	49
Trimming burrs	50
Miniature Burrs	51
Miniature burrs	52–53
Tool-sets	54–55
Burrs with TiAlN-coating	56
Rasp burrs	57
Rotary files	58
Tungsten Carbide Granulate non-ferrous metals	59
Burrs with extended shank length	60

with Imperial-Sized Shanks	61
Tools for stationary use	62
Tungsten Carbide Granulate tipped Tools	163–165
discs	165
Core Drill-Set	165

V

V2 Power, Lamellar Flap Disc	240–241
V3 Control, Lamellar Flap Disc	243
V4 Master, Lamellar Flap Disc	245

Notes

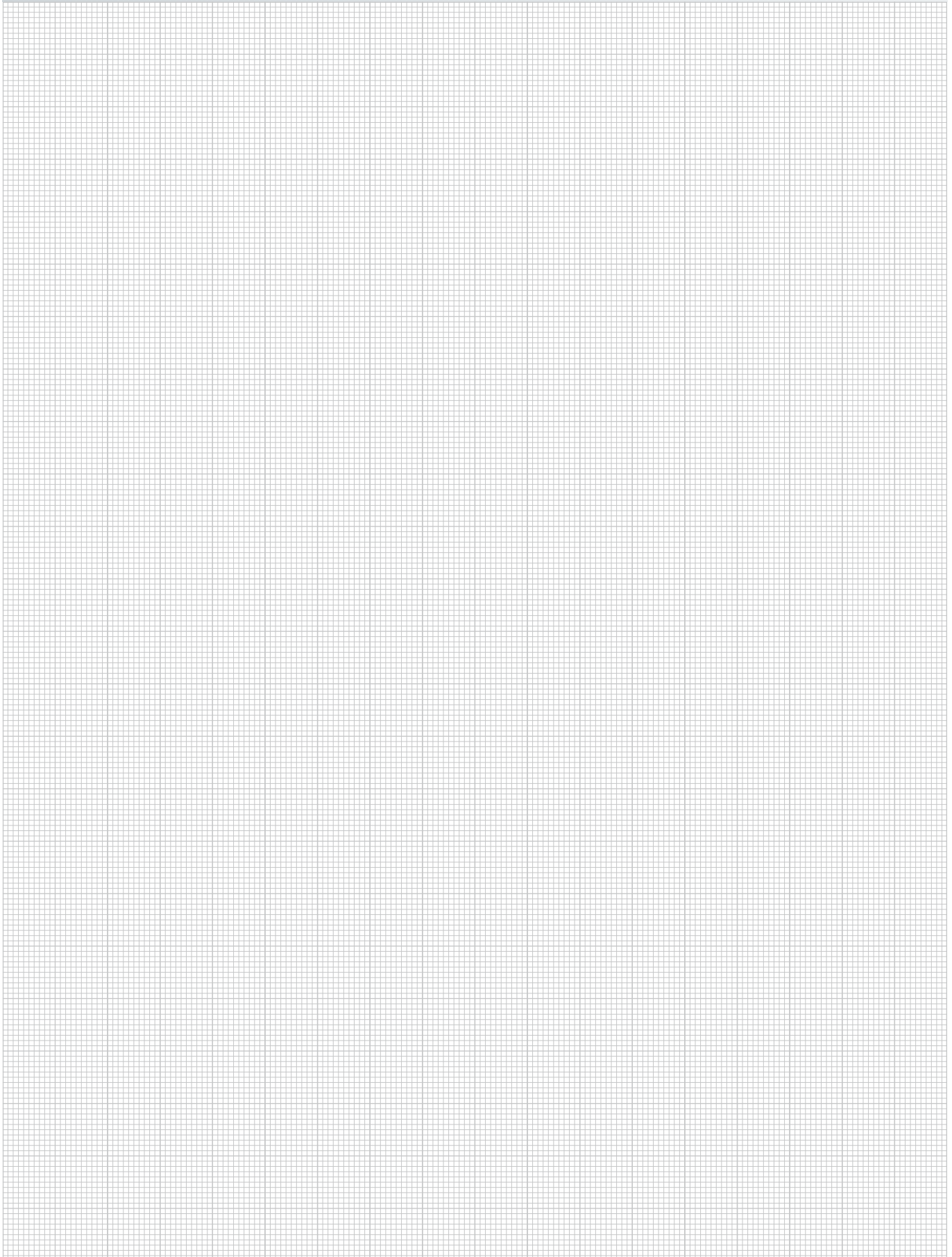
A large, empty grid area for taking notes, consisting of a fine grid of small squares. The grid is bounded by a light gray header bar at the top and a light gray footer bar at the bottom.

Notes

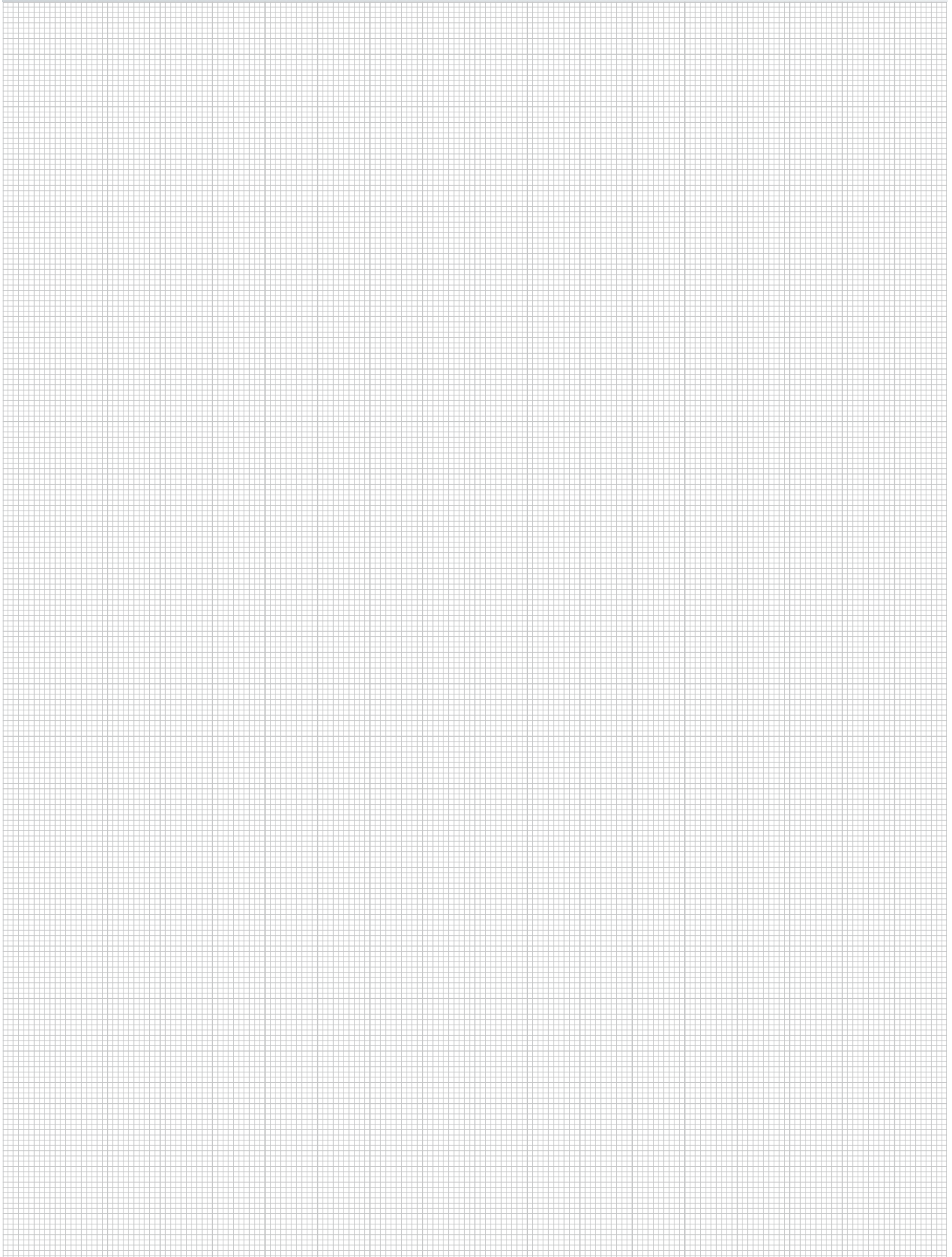
A large rectangular area filled with a fine grid pattern, intended for taking notes. The grid is composed of small, uniform squares.

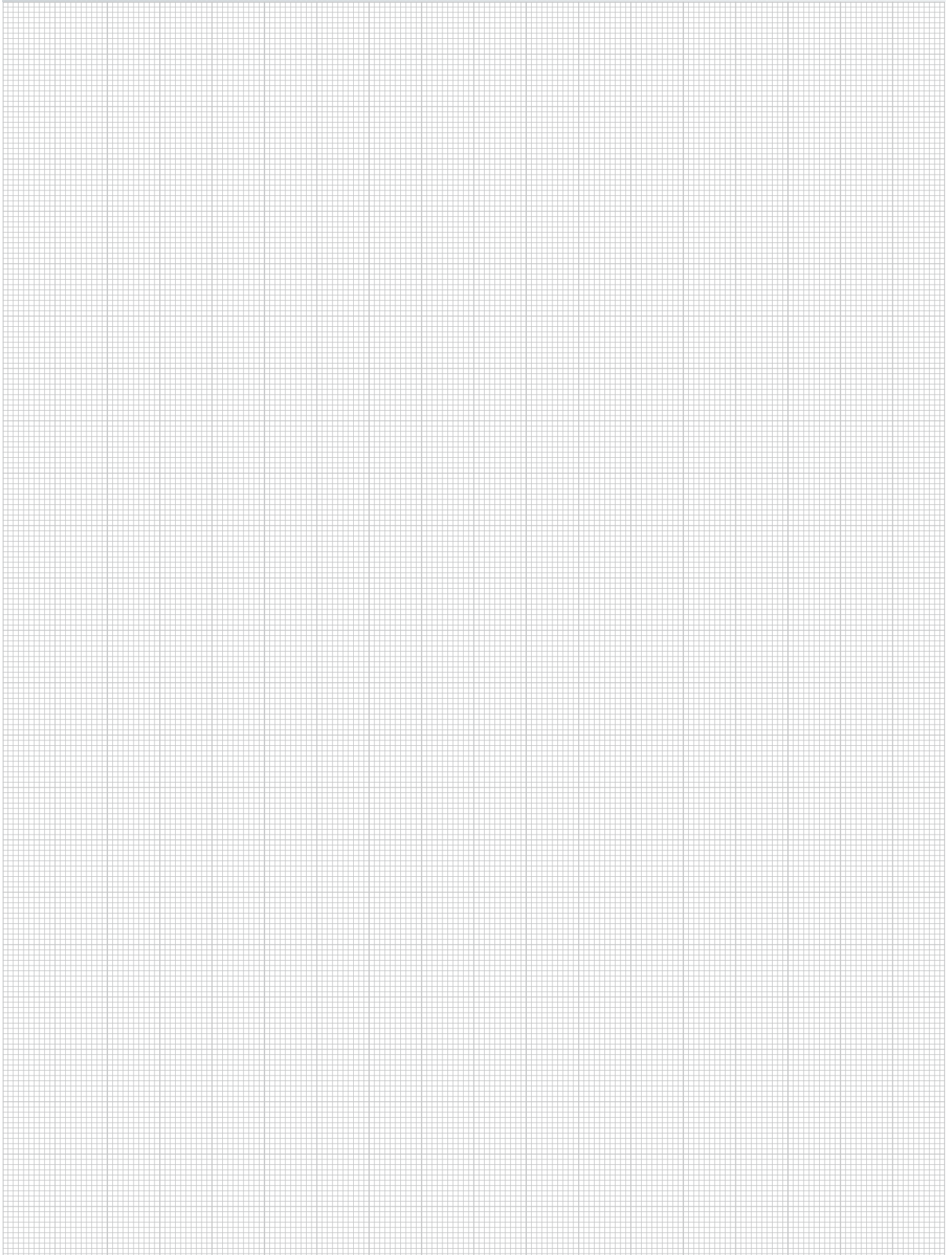
NotesA large, empty grid area for taking notes, consisting of a fine grid of small squares. The grid is bounded by a light gray header bar at the top and a light gray footer bar at the bottom.

Notes

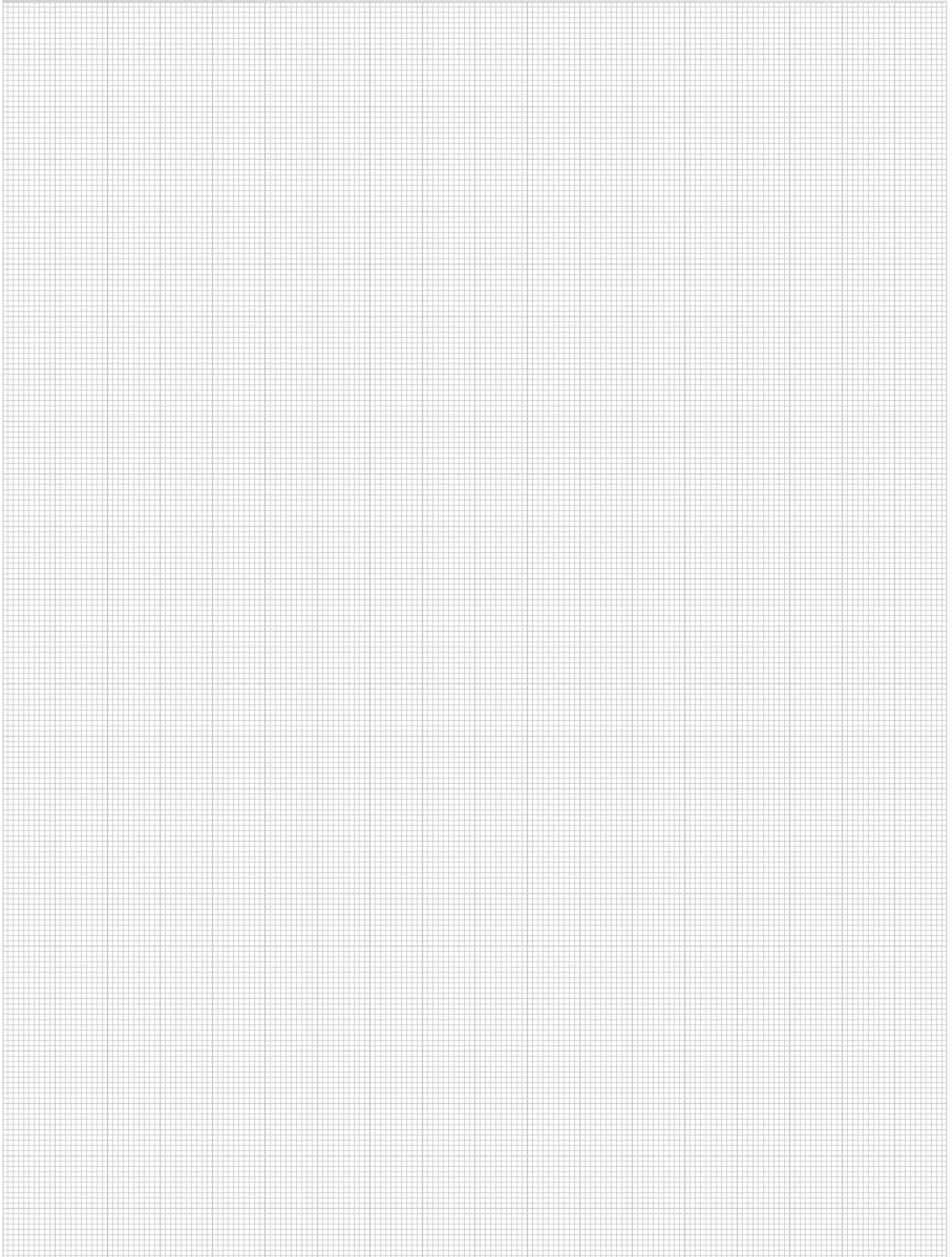
A large rectangular area filled with a fine grid pattern, intended for taking notes. The grid is composed of small squares and covers most of the page's content area.

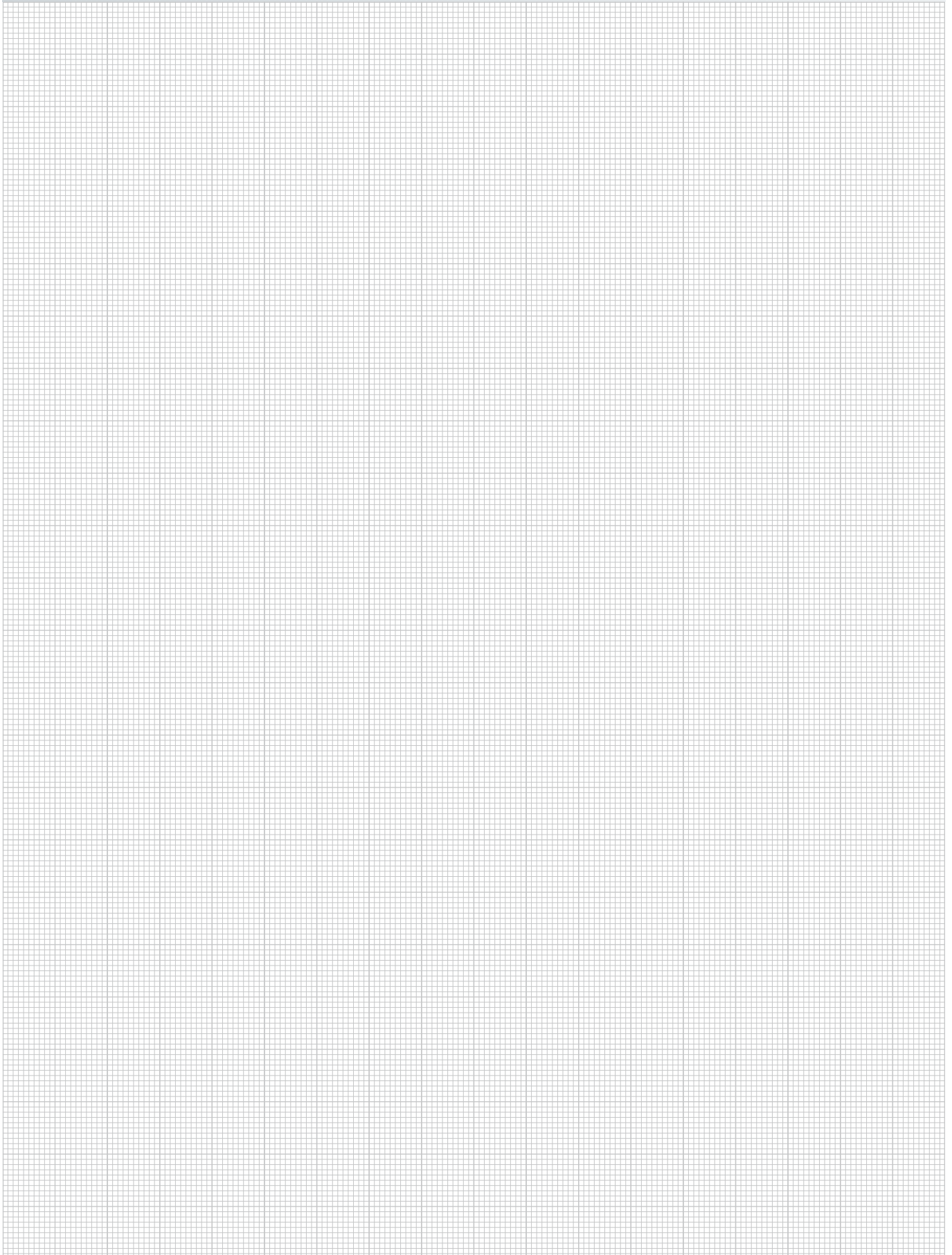
NotesA large, empty grid area for taking notes, consisting of a fine grid of small squares. The grid is bounded by a light gray header bar at the top and a light gray footer bar at the bottom.



Company headquarters



LUKAS-ERZETT Vereinigte Schleif- und Fräswerkzeugfabriken GmbH & Co. KG

Gebrüder-Lukas-Straße 1
51766 Engelskirchen
Fon +49 2263 84-0
Fax +49 2263 84-327 (Domestic Market)
Fax +49 2263 84-300 (Export Department)
le@lukas-erzett.de
www.lukas-erzett.com



Kayson Green Limited

Clough Road
Severalalls Business Park
Colchester
CO4 9QS Essex
Fon +44 1206 751500
Fax +44 1206 751212
abrasives@kaysongreen.co.uk



LUKAS-ERZETT Vereinigte Schleif- und Fräswerkzeugfabriken GmbH & Co. KG

Avd. de la Azucarera, Nave 14
28500 Arganda del Rey (Madrid)
Fon +34 900 974924
Fax +34 900 974925
le@lukas-erzett.de
www.lukas-erzett.com



Schleifscheibenfabrik Rottluff GmbH

Weideweg 17
09116 Chemnitz
Fon +49 371 369 95-0
Fax +49 371 369 95-30
info@rotluff.com



Beijing Representative Office

Room 2228
19th Floor
C-King Apartment
No. 19 Madian East Rd.
100080 Haidian District Beijing
Fon +86 10 82961338
Fax +86 10 82800015
beijing@lukas-erzett.com.cn



LUKAS CZ spol. s. r. o.

Tovární 478
35134 Skalná
Fon +420 357 070600
Fax +420 357 070613
obchod@lukascz.cz
www.lukas-erzett.com



LUKAS ABRASIVES SA (PTY) LTD.

1288 Harriet Avenue
Driehoek
1401 Germiston
Fon +27 11 8251550
Fax +27 11 8720144
abrasives@lukas.co.za
www.lukas.co.za

